

ULINE H-1069

6" CRIMPER HAND SEALER

1-800-295-5510
uline.com

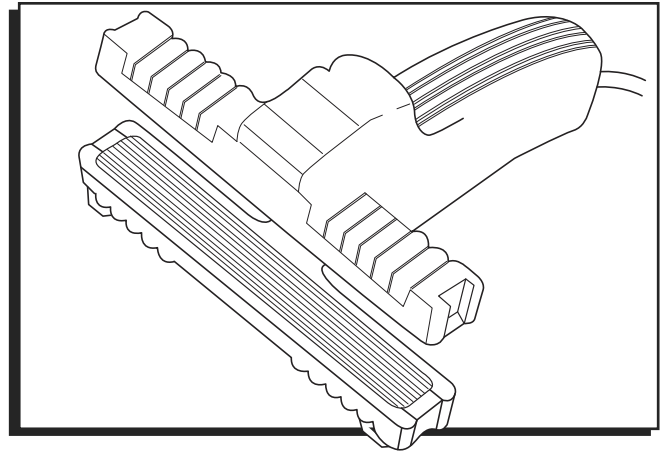

TROUBLESHOOTING

| OPERATING ISSUE | RECOMMENDATIONS |
|-----------------------------|---|
| Sealer is not heating up. | Sealer must be warmed up for 15 minutes prior to use. |
| Sealer is melting the bags. | Adjust dial to a lower setting to reduce the heat. See below for recommended settings. |
| Sealer is burning the bags. | The bag is made of polyethylene, fabric or another material which is not compatible with this sealer. |
| Sealer is not sealing. | Adjust dial to a higher setting to increase the heat. See below for recommended settings. |

RECOMMENDED SETTINGS



NOTE: The H-1069 6" Crimper Hand Sealer is designed to seal cellophane, polypropylene, and foil bags only.



CAUTION! DO NOT USE with polyethylene, fabric, burlap, Tyvek® or bags made of other materials.

| MIL | BAG TYPE | DIAL SETTINGS |
|-----|---------------|-----------------|
| 1.2 | Cellophane | 3 |
| 1.5 | Polypropylene | 3 |
| 3 | Polypropylene | Between 3 and 4 |
| 2.2 | Metallized | 4 |
| 5 | Foil | 4 |

ULINE H-1069

**SELLADORA
MANUAL DE 6"**

800-295-5510
uline.mx

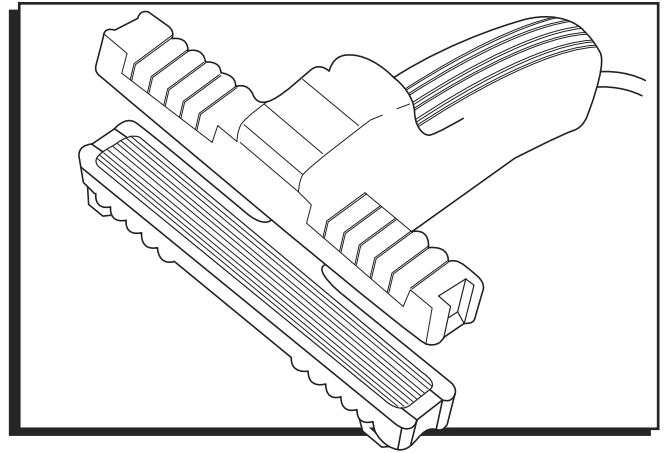

SOLUCIÓN DE PROBLEMAS

| PROBLEMA DE OPERACIÓN | RECOMENDACIONES |
|----------------------------------|--|
| La selladora no se calienta. | La selladora debe calentarse durante 15 minutos antes de estar lista para su uso. |
| La selladora derrite las bolsas. | Ajuste el control a una configuración menor para reducir el calor. Ver la configuración recomendada arriba. |
| La selladora quema las bolsas. | La bolsa está hecha de polietileno, tejido u otro material que no es compatible con esta selladora. |
| La selladora no sella. | Ajuste el control a una configuración mayor para aumentar el calor. Ver la configuración recomendada arriba. |

CONFIGURACIÓN RECOMENDADA



NOTA: La Selladora Manual de 6" H-1069 está diseñada para sellar solo bolsas de celofán, polipropileno y aluminio.



¡PRECAUCIÓN! NO USAR CON bolsas de polietileno, textil, yute, Tyvek® ni otros materiales.

| MIL | TIPO DE BOLSA | CONFIGURACIONES DEL DIAL |
|-----|---------------|--------------------------|
| 1.2 | Celofán | 3 |
| 1.5 | Polipropileno | 3 |
| 3 | Polipropileno | Entre 3 y 4 |
| 2.2 | Metalizada | 4 |
| 5 | Aluminio | 4 |

ULINE H-1069

**SCELLEUSE
MANUELLE DE
15,2 CM (6 PO)**

1-800-295-5510
uline.com

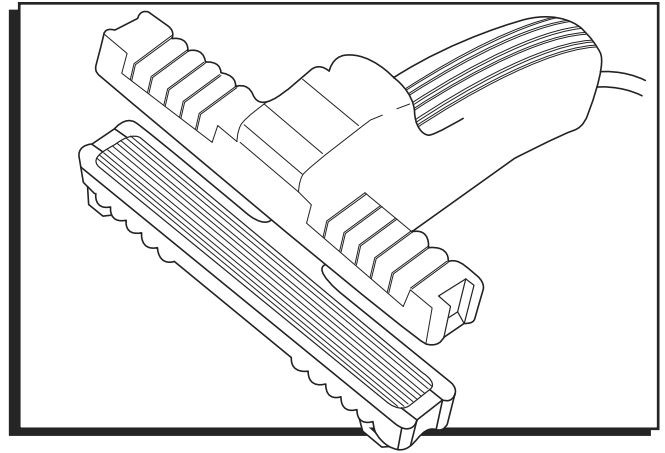

DÉPANNAGE

| PROBLÈME | RECOMMANDATIONS |
|------------------------------------|--|
| La scelleuse ne chauffe pas. | Laissez réchauffer la scelleuse pendant 15 minutes avant de l'utiliser. |
| La scelleuse fait fondre les sacs. | Réglez le cadran à une valeur inférieure pour réduire la chaleur. Consultez les réglages recommandés ci-dessous. |
| La scelleuse brûle les sacs. | Le sac est composé de polyéthylène, de tissu ou d'un autre matériau qui n'est pas compatible avec cette scelleuse. |
| La scelleuse ne scelle pas. | Réglez le cadran à une valeur supérieure pour augmenter la chaleur. Consultez les réglages recommandés ci-dessous. |

RÉGLAGES RECOMMANDÉS



REMARQUE : La scelleuse manuelle de 15,2 cm (6 po) H-1069 est conçue pour sceller uniquement des sacs en cellophane, en polypropylène et en papier d'aluminium.



MISE EN GARDE! N'UTILISEZ PAS du polyéthylène, du tissu, de la toile de jute, des enveloppes Tyvek^{MD} ou des sacs faits de tout autre matériau.

| MIL | TYPE DE SAC | RÉGLAGES DU CADRAN |
|-----|---------------|--------------------|
| 1,2 | Cellophane | 3 |
| 1,5 | Polypropylène | 3 |
| 3 | Polypropylène | Entre 3 et 4 |
| 2,2 | Métallisé | 4 |
| 5 | Aluminium | 4 |