

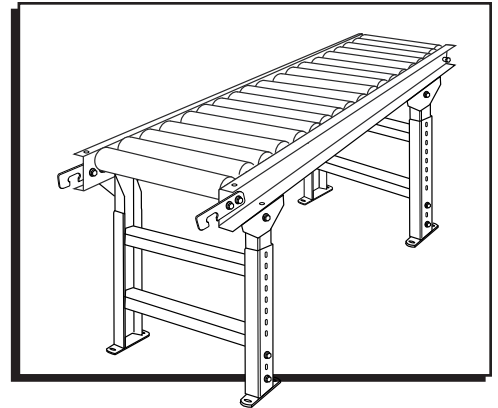

H-5012, H-5013  
H-5016

1-800-295-5510  
uline.com

# 18" LIGHT DUTY CONVEYOR



CONVEYOR

END VIEW

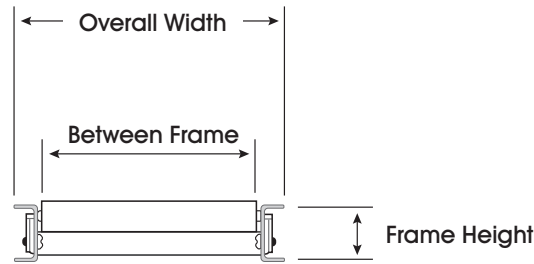

TOP VIEW

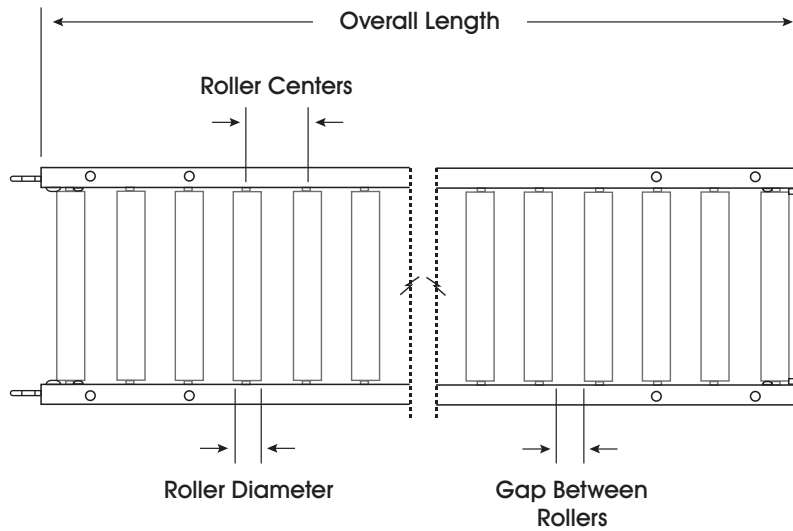

## CONVEYOR SPECIFICATIONS

MODEL #	WIDTH		FRAME HEIGHT	ROLLER DIAMETER	ROLLER CENTERS	GAP BETWEEN ROLLERS	OVERALL LENGTH
	OVERALL WIDTH	BETWEEN FRAME					
H-5012	18"	16"	2.5"	1 3/8"	3"	1 3/8"	5'
H-5013							10'

# SPECIFICATIONS CONTINUED

## H-STAND

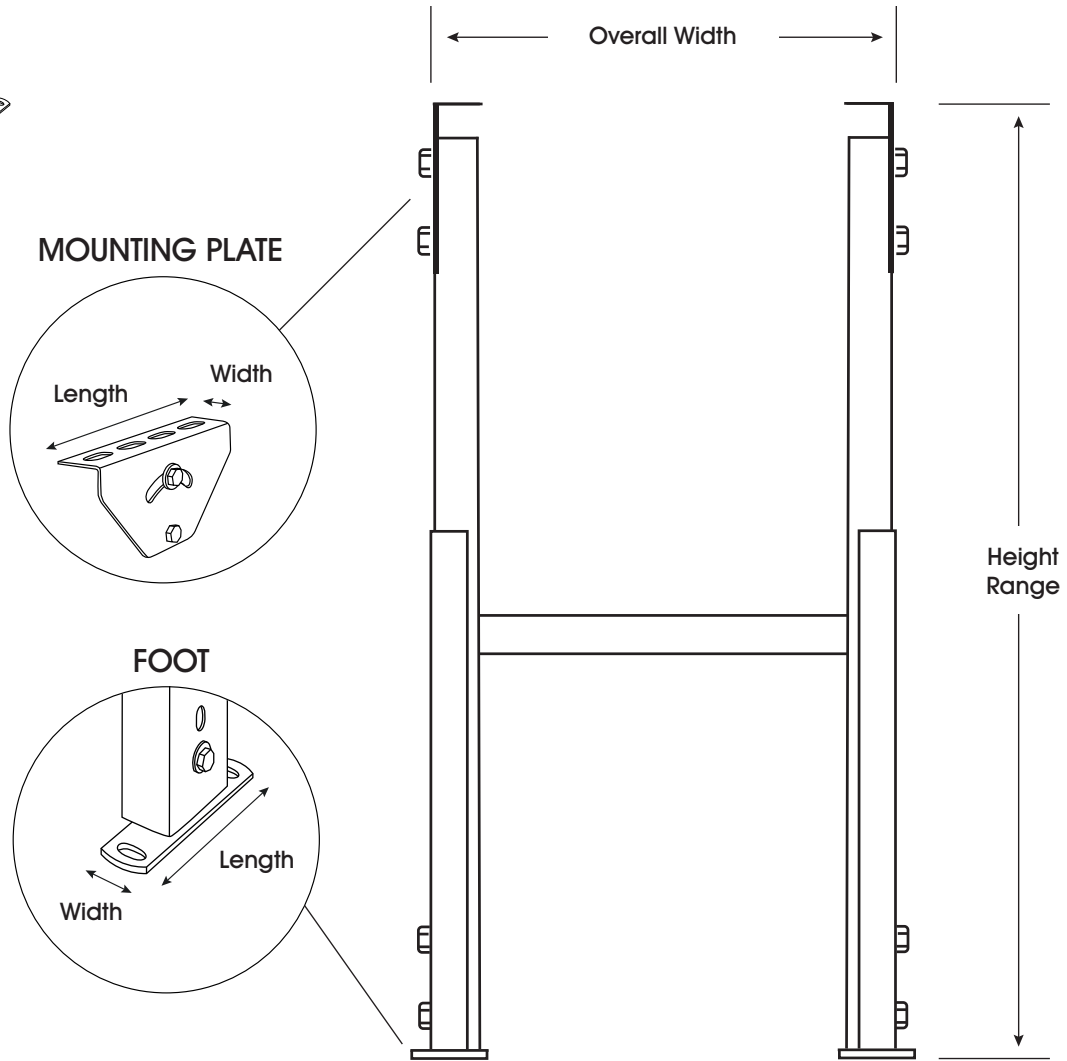
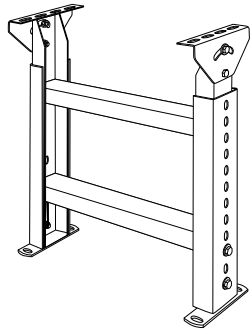

## H-STAND SPECIFICATIONS

MODEL #	OVERALL WIDTH	HEIGHT RANGE	MOUNTING PLATE LENGTH	MOUNTING PLATE WIDTH	FOOT LENGTH	FOOT WIDTH
H-5016	18"	24-36"	8"	1"	6.25"	0.5"

**ULINE** CHICAGO • ATLANTA • DALLAS • LOS ANGELES • MINNEAPOLIS • NYC/PHILA • SEATTLE • MEXICO • CANADA

1-800-295-5510

uline.com