

ULINE H-1020, H-1619
 H-1675, H-7208
**SEMI-AUTOMATIC
 STRETCH WRAP MACHINE**

1-800-295-5510
 uline.com

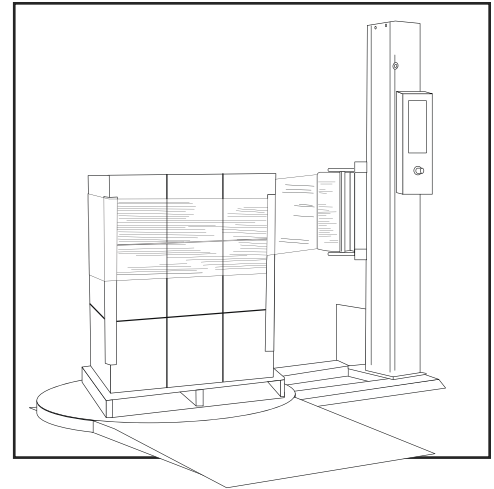

ELECTRICAL SYSTEM PARTS LIST

DESCRIPTION	QTY.	ULINE PART NO.	MFG. PART NO.
Microprocessor Card	1	H-1020-CARD	401495
Transformer Card	1	H-1020-TRANS	401361
Fuse, 250 VAC, 1 AMP, GMA	2	H-1020-01362	401362
Fuse, 250 VAC, 10 AMP, GMA	2	H-1020-03261	403261
Fuse, 250 VAC, 5 AMP, GMA	2	H-1020-01365	401365
Relay LY2 DC24V	5	H-1020-00630	401366
Button, White	1	H-1020-01367	401367
Button Seat Contactor Nox1	1	-----	401368
Auto Run Green Lamp: Cover	1	H-1020GSB	400609
Auto Run Green Lamp: Seat	1	-----	400610
Auto Run Green Lamp: Light	1	H-1020-00611	400611
Knob RN-99F, Ø6.4	2	H-1020-01371	401371
Various Resistor 5K	2	-----	400649
EMG. Switch	1	-----	401372
Button Seat Contactor NCx1	1	H-1020-01373	401373
Main Power Switch	1	H-1020-PWRSW	401374
Limit Switch TZ-8108	2	H-1020-00639	400639
Limit Switch TM-1307	1	H-1020-00636	400636
Proximity Switch PS-05N-3M	1	H-1020-00641	400641
Limit Switch TZ-7110	1	H-1020-00637	400637
Photo Sensor A3R-2MX (Optional)	1	H-1020-00643	400643
Fan, 3.15", 110-120 VAC	1	H-1020-04261	404261
Fuse Holder	1	H-1020-04262	404262
Fuse, 0.2A, 1.18"	1	H-1020-04263	404263
Button Membrane Label for Control Panel	1	H-1020-LBL	310008
Carriage Control Cable	1	H-1020-CNTRL	403409

SEMI-AUTOMATIC STRETCH WRAP MACHINE

TURNTABLE FRAME ASSEMBLY

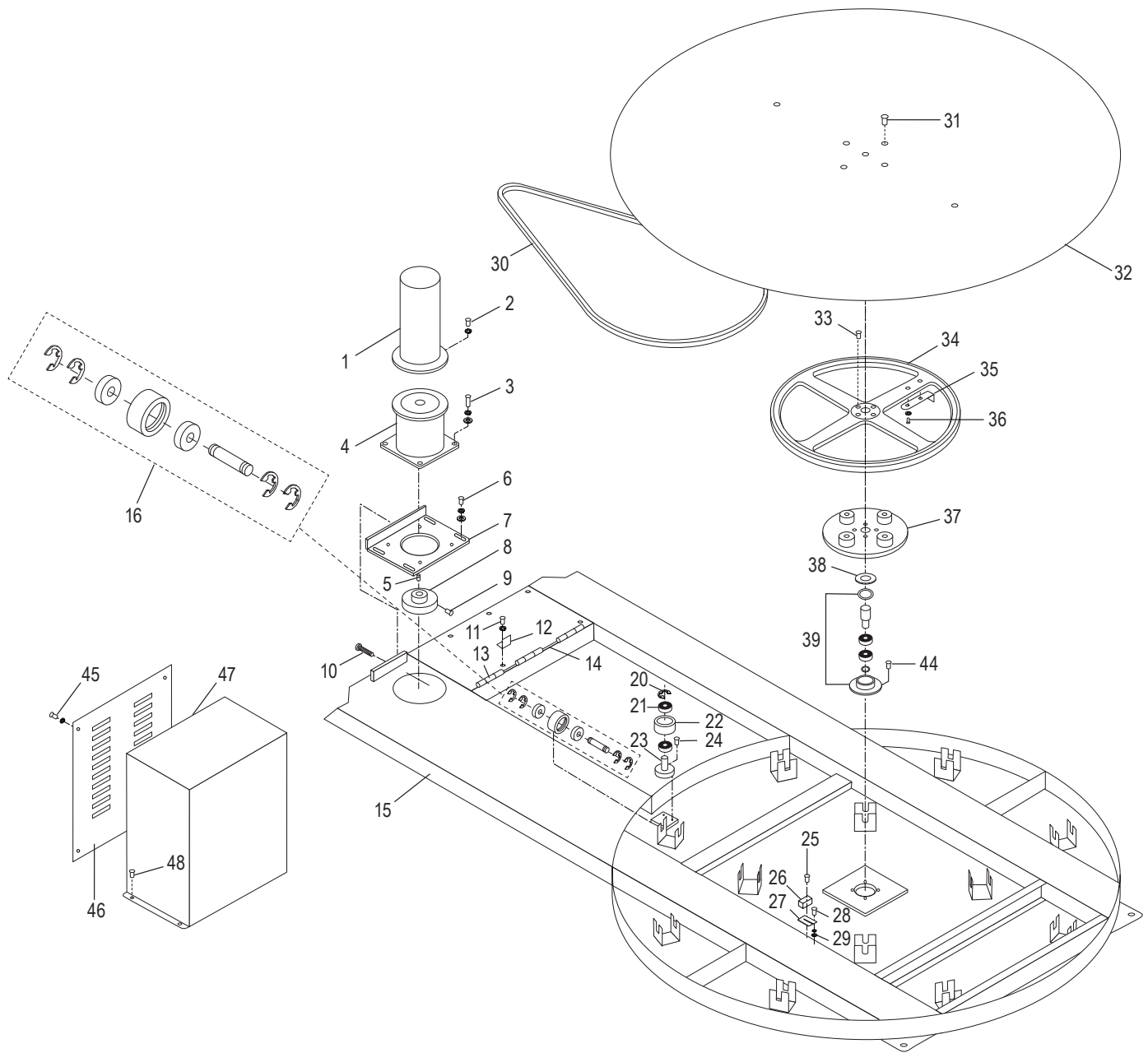



H-1020, H-1619
H-1675, H-7208

1-800-295-5510
uline.com

SEMI-AUTOMATIC STRETCH WRAP MACHINE

TURNTABLE FRAME PARTS LIST

#	DESCRIPTION	QTY.	ULINE PART NO.	MFG. PART NO.
1	Motor	1	H-1020-37	300037
2	Screw M8 x 20L & W	4	-----	200091
3	Screw M10 x 20L & SW & W	4	-----	200092
4	Speed Reducer	1	H-1020-00031	300031
5	Key 5 x 20L	1	-----	300002
6	Screw M10 x 25L & SW & W	4	-----	200093
7	Motor Adjust Seat 1.5M	1	-----	500034
8	Motor Pulley 4" 22 1.5M	1	-----	500014
9	Set Screw M8 x 10L	2	-----	207303
10	Screw M10 x 70L	1	-----	200095
11	Screw M6 x 12L & W	1	H-1020-M6X12	200077
12	Motor Box Fix Plate	1	-----	500083
13	Pin	2	-----	500087
14	Ring STW-10	2	-----	300006
15	Turntable Seat 1.5M	1	-----	600000
16	Cam Follower Assembly Includes: • Ring STW-17 #17 (4) • Bearing 6203ZZ #18 (2) • Supporting Plastic Wheel 1.5M #19 (1) • Supporting Plastic Wheel Shaft 1.5M #20 (1)	1	H-1020-CAM	700060
20	Ring STW-17	1	H-1020-00009	300009
21	Bearing 6203ZZ	2	H-1287-18	305300
22	Belt Lock Pulley	1	H-1287-20	500011
23	Belt Lock Pulley Shaft	1	H-1020-23	500012
24	Screw M6 x 16L	3	H-1020-M6X16	200078
25	Screw M3 x 25L & W	2	-----	200098
26	Proximity Switch PS-05N-3M	1	H-1020-00641	400641
27	Proximity Switch Fix Seat	1	H-1020FIXSET	500013
28	Screw M4 x 20L	2	-----	200103
29	Nut M5	6	-----	200128



H-1020, H-1619
H-1675, H-7208

1-800-295-5510
uline.com

SEMI-AUTOMATIC STRETCH WRAP MACHINE

TURNTABLE FRAME PARTS LIST CONTINUED

#	DESCRIPTION	QTY.	ULINE PART NO.	MFG. PART NO.
30	Belt B-172 1.5M	1	H-1020-00013	300013
31	Screw M8 x 25L	4	H-1020-M825L	200113
32	Turntable Plate 1.5M	1	H-1020-TPLT	500004
33	Screw M8 x 20L	4	H-1020-M820L	200084
34	Wheel 22"	1	H-1020-PLYDS	500007
35	Locating Plate	1	H-1020-35	500006
36	Screw M5 x 10L & W	4	-----	200108
37	Pulley Fixing Plate	1	H-1287-34DS	500008
38	Belt Pulley Seat Ring	1	H-1287-BPSR	500085
39	King Post Assembly Includes: • Ring RTW42 • Belt Pulley Shaft • Bearing 600422 • Ring STW-20 • Belt Pulley Bearing Seat	1	H-2304-KING	700058
44	Screw M10 x 16L	4	H-1287-41	200088
45	Screw M4 x 8L & W	4	-----	200100
46	Motor Cover 1.5M	1	H-3700-MCVR	500081
47	Turntable Motor Box 1.5M	1	H-1020-MTRBX	600028
48	Screw M4 x 8L & W	2	-----	200100
	Power Cord (Not Shown)	1	H-1020-POWER	400743



H-1020, H-1619
H-1675, H-7208

1-800-295-5510
uline.com

SEMI-AUTOMATIC STRETCH WRAP MACHINE

TOWER ASSEMBLY

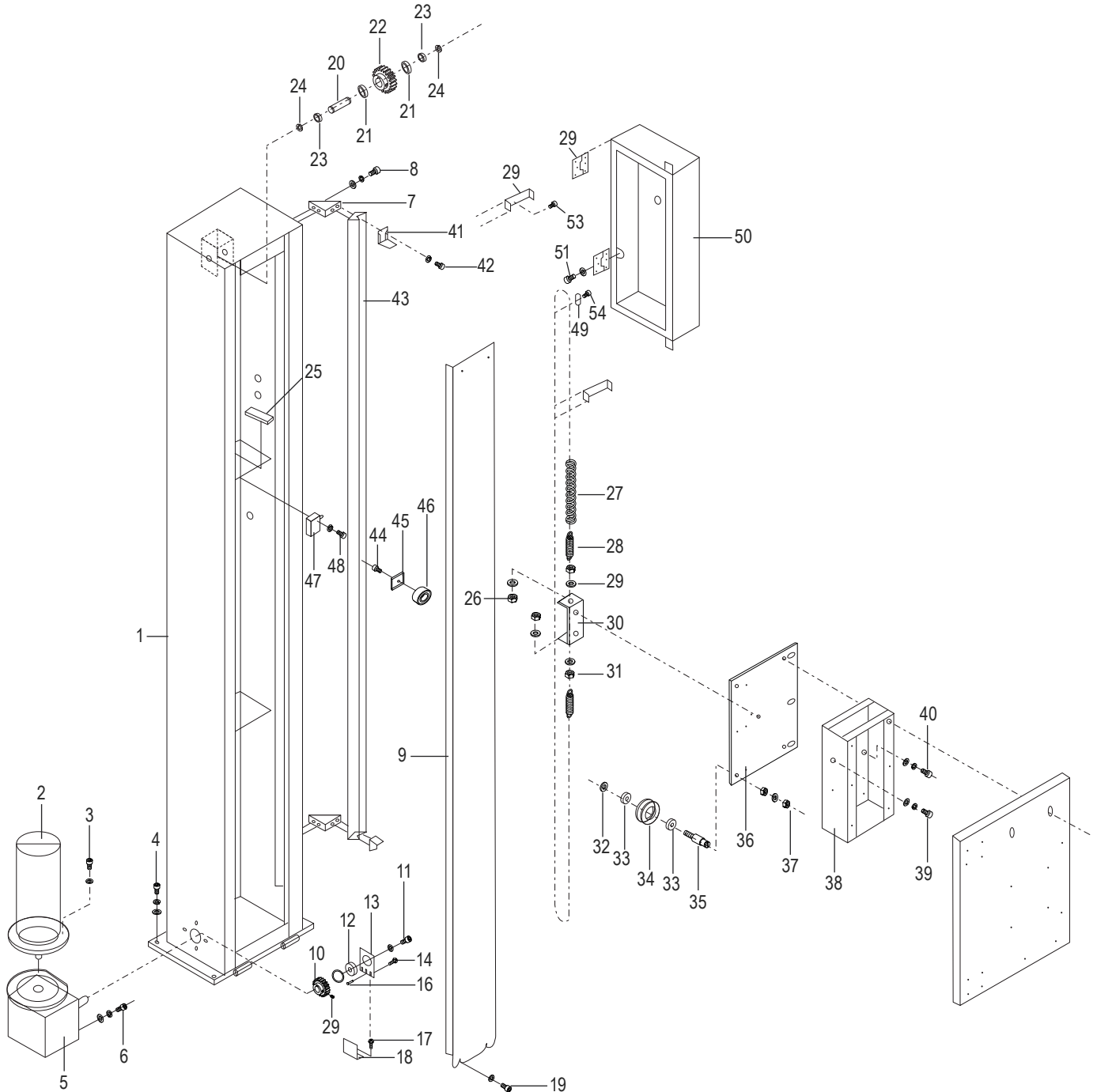



H-1020, H-1619
H-1675, H-7208

1-800-295-5510

uline.com

SEMI-AUTOMATIC STRETCH WRAP MACHINE

TOWER ASSEMBLY PARTS LIST

#	DESCRIPTION	QTY.	ULINE PART NO.	MFG. PART NO.
1	Tower 2.1M (For H-1020)	1	-----	500492
1	Tower 2.6M (For H-1675)	1	-----	500134
2	Elevator Motor Unit VP3310D	1	H-1675-00038	300038
3	Screw M8 x 20L & SW	4	-----	200091
4	Screw M10 x 25L & SW & W	5	-----	200090
5	Elevator Unit Speed Reducer VTM-40	1	H-1020-REDUQ	300030
6	Screw M8 x 25L & SW & W	4	-----	200085
7	Channel Support	2	H-3700-00135	500135
8	Screw M6 x 16L & SW & W	4	H-1020-M6X16	200078
9	Chain Wheel Cover 2.1M (For H-1020)	1	-----	500136
9	Chain Wheel Cover 2.6M (For H-1675)	1	-----	500137
10	Up & Down Chain Wheel (Lower) 11 Teeth	1	-----	500041
11	SHCS, M6 x 16L & SW & W	2	-----	200802
12	Bearing 6202-2NR	1	-----	300020
13	Speed Reducer Bearing Seat	1	-----	500102
14	Screw M4 x 6L & W	2	-----	200099
15	Screw M6 x 8L	1	-----	200120
16	Pin 4 x 8	1	-----	300000
17	Screw M8 x 12L	2	-----	200082
18	Bearing Adjust Seat	1	-----	500103
19	Screw M6 x 12L & W	4	H-1020-M6X12	200077
20	Upper Chain Wheel Shaft	1	-----	500003
21	Bearing 6002ZZ	2	-----	300017
22	Upper Chain Wheel	1	-----	500118
23	Ring	2	-----	500093
24	Ring STW-15	2	-----	300008
25	Adjust Bar Washer	1	-----	501864
26	Nut M12	1	-----	200140
27	Chain 2.1M (For H-1020)	1	H-1020-2.1M	300049
27	Chain 2.6M (For H-1675)	1	-----	300050
28	Elevator Unit Chain Screw Shaft	2	-----	500025
29	Washer M12	4	-----	200147
30	Chain Adjust Seat	1	-----	500092
31	Nut M12	3	-----	200133
32	Ring STW-12	6	-----	300007
33	Bearing 6001ZZ	8	-----	300016
34	Up & Down Driving Wheel	4	-----	500090



H-1020, H-1619
H-1675, H-7208

1-800-295-5510
uline.com

SEMI-AUTOMATIC STRETCH WRAP MACHINE

TOWER ASSEMBLY PARTS LIST CONTINUED

#	DESCRIPTION	QTY.	ULINE PART NO.	MFG. PART NO.
35	Up & Down Driving Wheel Shaft	4	-----	500091
36	Chain Wheel Seat	1	-----	500040
37	Nut M10 & SW & W	6	-----	200131
38	Elevator Unit Seat (Inner)	1	-----	600008
39	Screw M8 x 20L & SW & W	2	H-1020-M820L	200084
40	Screw M8 x 16L & SW & W	6	-----	200083
41	Limit Plate	2	-----	500138
42	Screw M6 x 16L & SW & Nut	4	-----	200125
43	Channel 2.1M (For H-1020)	1	H-3700-00139	500139
43	Channel 2.6M (For H-1675)	1	-----	500140
44	Screw M6 x 16L	1	H-1020-M6X16	200078
45	Fix Piece	1	H-1020-FIXPC	500141
46	Handle Wheel	1	H-1020-HNDWH	500142
47	Limit Switch TZ-7110	1	H-1020-00637	400637
48	Screw M4 x 30L & W	2	-----	200105
49	Lock with Key	2	-----	300015
50	Control Box	1	H-1020-00143	500143
50a	Button Membrane Label for Control Panel	1	H-1020-LBL	310008
51	Screw M6 x 10L & SW	1	-----	200076
52	Lock Latch Plate	2	-----	300048
53	Screw M6 x 10L & SW	4	H-2957-MSCRW	200766
54	Screw M5 x 16L	1	-----	204905
55	Hinge	2	-----	500106
	Key (Not Shown)	2	H-1020-KEYS	300046
	Lock with Key (Not Shown)	2	H-1020TWRKEY	300041
	Fan (Not Shown)	1	H-1020-FAN	403567



H-1020, H-1619
H-1675, H-7208

1-800-295-5510
uline.com

SEMI-AUTOMATIC STRETCH WRAP MACHINE

FILM CARRIAGE ASSEMBLY

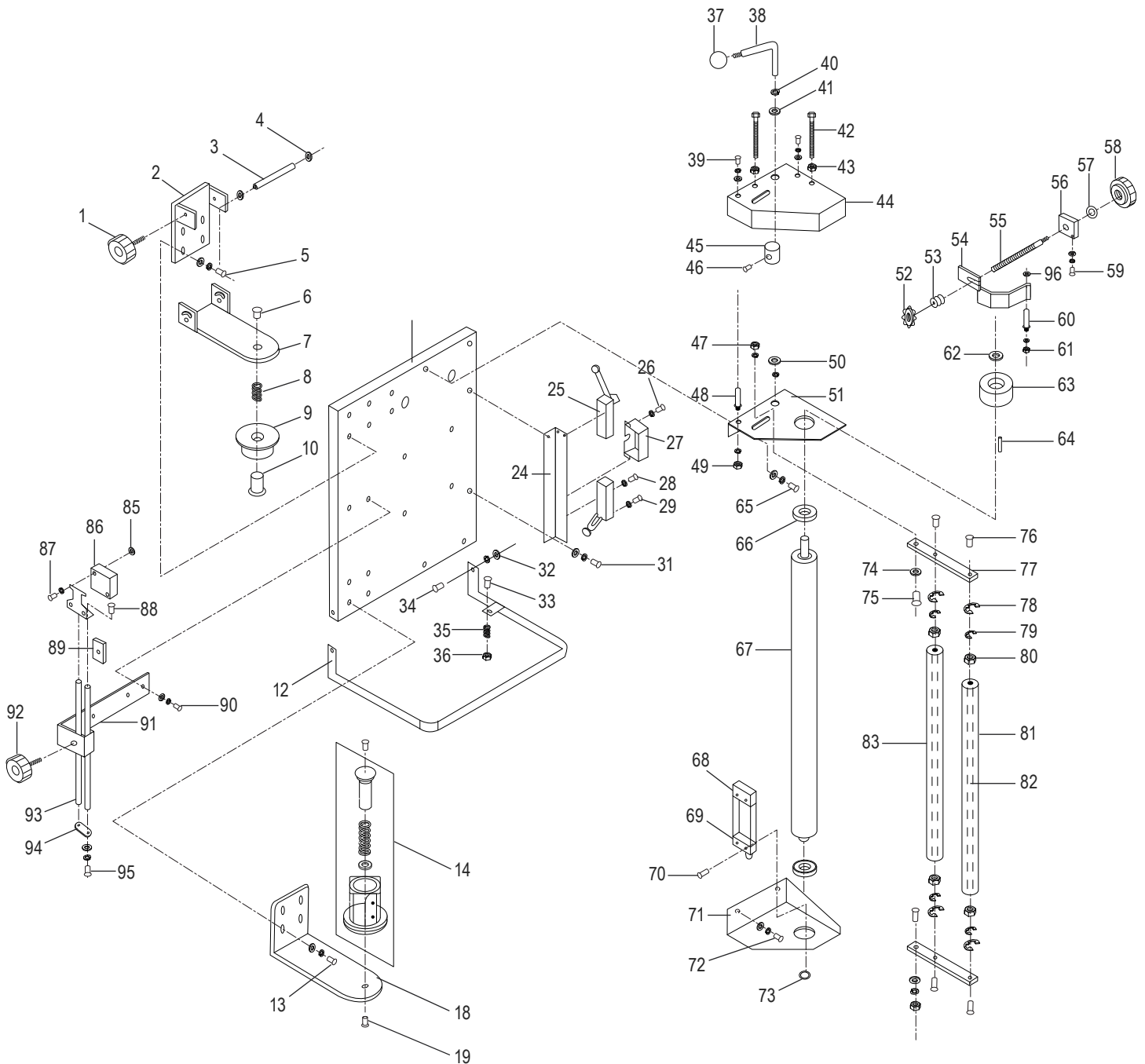



H-1020, H-1619
H-1675, H-7208

1-800-295-5510

uline.com

SEMI-AUTOMATIC STRETCH WRAP MACHINE

FILM CARRIAGE PARTS LIST

#	DESCRIPTION	QTY.	ULINE PART NO.	MFG. PART NO.
1a	Handle	1	H-1020HANDLE	500000
1b	Knob Threaded Rod	1	-----	204908
2	Film Fix Seat (Upper)	1	-----	500144
3	Shaft	1	-----	500145
4	Ring STW-10	2	-----	300006
5	Screw M6 x 20L & SW & W	4	-----	200079
6	Screw M10 x 20L	1	H-2957-FHCS	200627
7	Film Moving Shaft	1	-----	500146
8	Film Seat Spring	1	-----	500147
9	Film Seat (Upper)	1	-----	500148
10	Film Seat Shaft	1	-----	500101
11	Elevator Unit Seat (Outer) – 20"	1	-----	500149
11	Elevator Unit Seat (Outer) – 30"	1	-----	504260
12	Pedal	1	H-1020-FTPED	500150
13	Screw M6 x 20L & SW & W	4	-----	200079
14	Lower Core Holder Assembly Includes: • Film Seat Shaft • Spring • Bearing NTB/A51730 • Film Core Holder • Film Core Brake Plate • Film Brake Disc • Washer	1	H-1619-LCORE	700072
18	Film Six Seat (Lower)	1	-----	500151
19	Screw M10 x 20L	1	-----	200089
24	Limit Switch Seat	1	-----	500152
25	Limit Switch TZ-8108	2	H-1020-00639	400639
26	Screw M4 x 12L	2	-----	200101
27	Terminal Cover	1	-----	500130
28	Screw M4 x 16L	4	-----	200102
29	Screw M4 x 12L	4	-----	200101
31	Screw M6 x 12L & SW & W	2	H-1020-M6X12	200077
32	Nut M6	2	-----	200137
33	Screw M4 x 20L	1	-----	200103
34	Screw M6 x 20L	2	-----	200079
35	Spring	1	-----	500016
36	Nut M4	2	-----	200127
37	Handle Knob	1	H-1020HANDLE	500913
38	Handle	1	-----	500153



H-1020, H-1619
H-1675, H-7208

1-800-295-5510

uline.com

SEMI-AUTOMATIC STRETCH WRAP MACHINE

FILM CARRIAGE PARTS LIST CONTINUED

#	DESCRIPTION	QTY.	ULINE PART NO.	MFG. PART NO.
39	Screw M6 x 12L & SW & W	2	H-1020-M6X12	200077
40	Ring STW-10	1	-----	300006
41	Ring	1	-----	500154
42	Screw M6 x 100L	2	-----	200157
43	Nut M6	4	-----	200129
44	Stretch Seat Cover (Upper)	1	-----	500155
45	Wheel	1	-----	500156
46	Screw M6 x 10L	1	-----	200121
47	Nut M8 & SW	2	-----	200130
48	Stretch Seat Shaft	1	-----	500157
49	Nut M8 & W	1	-----	200130
50	Ring	1	-----	500158
51	Upper Stretch Seat	1	-----	500159
52	Tension Adjust Seat	1	-----	500160
53	Stretch Spring	1	H-1020-SPRNG	500161
54	Brake Plate	1	H-1020-00162	500162
55	Tension Adjust Screw	1	H-1020-BSCRW	500163
56	Gear Screw Fix Seat	1	-----	500164
57	Ring	1	-----	500154
58	Handle	1	H-1020HANDLE	500000
59	Screw M6 x 12L & SW & W	2	H-1020-M6X12	200077
60	Break Plate Shaft	1	-----	500165
61	Nut M6 & SW	2	-----	200129
62	Break Wheel Fix Shaft	1	-----	500166
63	Break Wheel	1	-----	500167
64	Pin 5 x 5 x 20L	1	-----	300002
65	Screw M8 x 20L & SW & W	2	H-1020-M820L	200084
66	Bearing 6004ZZ-NR	2	H-1020-BEARN	300051
67	Pre-Stretch Shaft – 20"	1	H-1020-PSHFT	500168
67	Pre-Stretch Shaft – 30"	1	-----	504261
68	Wire Protector	1	-----	400640
69	Limit Switch TM-1307	1	H-1020-00636	400636
70	Screw M4 x 25L	2	-----	200104
71	Lower Stretch Seat	1	-----	500169
72	Screw M8 x 20L & SW & W	2	H-1020-M820L	200084
73	Ring STW-20	1	H-1287-STW20	300010
74	Ring	2	-----	500158
75	Moving Shaft Pin	2	-----	500170
76	Screw M6 x 12L	4	H-1020-76	200833



H-1020, H-1619
H-1675, H-7208

1-800-295-5510
uline.com

SEMI-AUTOMATIC STRETCH WRAP MACHINE

FILM CARRIAGE PARTS LIST CONTINUED

#	DESCRIPTION	QTY.	ULINE PART NO.	MFG. PART NO.
77	Moving Shaft (For H-1020)	1	-----	500171
77	Moving Shaft (For H-1675)	1	-----	500172
78	Ring STW-22	4	H-1020-78	300052
79	Ring STW-10	4	H-1020-79	300006
80	Bearing 6000ZZ	4	H-1020-80	300015
81	Idler Roller- 30"	1	H-1020-81	504262
82	Idler Roller Shaft – 20"	2	H-1020-82	500174
82	Idler Roller Shaft – 30"	2	-----	504263
83	Idler Roller – 20"	1	-----	500175
83	Idler Roller – 30"	1	-----	504264
85	Nut M4 (Option)	2	-----	200127
86	Photo Sensor A3R-2MX	1	H-1020-00643	400643
87	Screw M4 x 12L & W (Option)	2	-----	200101
88	Screw M6 x 12L (Option)	2	-----	200110
89	Fix Piece (Option)	1	-----	500094
90	Screw M6 x 20L & SW & W (Option)	2	-----	200079
91	Photo Sensor Adjust Seat (Option)	1	-----	500176
92	Handler (Option)	1	H-1020HANDLE	500000
93	Photo Sensor Adjust Bar (Option)	2	-----	500095
94	Connecting Plate (Option)	1	-----	500096
95	Screw M6 x 12L & SW & W (Option)	2	H-1020-M6X12	200077
96	Spacer, Anti Squeak	1	-----	304629
	Brake (Not Shown)	1	-----	500111
	Film Brake Plate (Not Shown)	1	-----	500109
	Film Six Seat (Not Shown)	1	-----	500107
	Screw M6 x 20L & SW & W (Not Shown)	2	-----	200079
	Washer (Not Shown)	1	-----	500112

ULINE H-1020, H-1619
H-1675, H-7208

MÁQUINA SEMIAUTOMÁTICA PARA PELÍCULA ELÁSTICA

800-295-5510
uline.mx

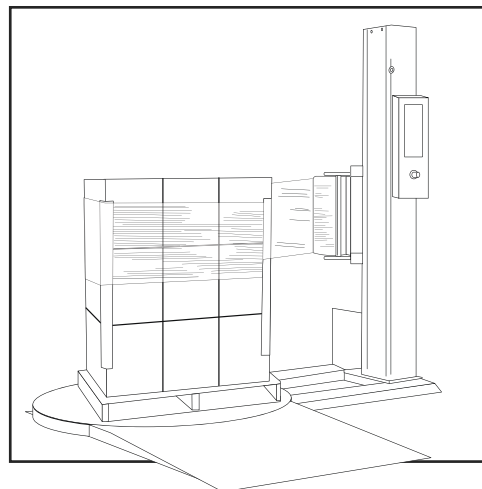

LISTA DE PARTES DEL SISTEMA ELÉCTRICO

DESCRIPCIÓN	CANT.	NO. DE PARTE DE ULINE	NO. DE PARTE DEL FABRICANTE
Tarjeta del Microprocesador	1	H-1020-CARD	401495
Tarjeta del Transformador	1	H-1020-TRANS	401361
Fusible, 250 VAC, 1 AMP, GMA	2	H-1020-01362	401362
Fusible, 250 VAC, 10 AMP, GMA	2	H-1020-03261	403261
Fusible, 250 VAC, 5 AMP, GMA	2	H-1020-01365	401365
Interruptor de Salida LY2 DC24V	5	H-1020-00630	400630
Botón, Blanco	1	H-1020-01367	401367
SopORTE del Botón del Contactor Nox1	1	-----	401368
Luz Verde del Proceso Automático: Cubierta	1	H-1020GSB	401369
Luz Verde del Proceso Automático: Soporte	1	H-1020MB	401370
Luz Verde del Proceso Automático: Foco	1	H-1020-00611	400611
Perilla RN-99F, Ø6.4	2	H-1020-01371	401371
Varias Resistencias 5K	2	H-1020-08117	408117
EMG. Interruptor	1	H-1020-00613	400613
SopORTE del Botón del Contacto NCx1	1	H-1020-01373	401373
Interruptor Principal de Corriente	1	H-1020-PWRSW	401374
Interruptor de Límite TZ-8108	2	H-1020-00639	400639
Interruptor de Límite TZ-1307	1	H-1020-00636	400636
Interruptor de Proximidad PS-05N-3M	1	H-1020-00641	400641
Interruptor de Límite TZ-7110	1	H-1020-00637	400637
Foto Sensor A3R-2MX (Opcional)	1	H-1020-00643	400643
Ventilador, 80 mm (3.15"), 110-120 VAC	1	H-1020-04261	404261
SopORTE del Fusible	1	H-1020-04262	404262
Fusible, 0.2A, 30 mm (1.18")	1	H-1020-04263	404263
Etiqueta del Botón de la Membrana para el Tablero de Control	1	H-1020-LBL	310008
Cable de Control del Portador	1	H-1020-CNTRL	403409



H-1020, H-1619
H-1675, H-7208

MÁQUINA SEMIAUTOMÁTICA PARA PELÍCULA ELÁSTICA

800-295-5510
uline.mx

LISTA DE PARTES DE LA PLATAFORMA GIRATORIA

#	DESCRIPCIÓN	CANT.	NO. DE PARTE DE ULINE	NO. DE PARTE DEL FABRICANTE
1	Motor	1	H-1020-37	300037
2	Tornillo M8 x 20L y Rondana	4	-----	200091
3	Tornillo M10 x 20L y Tornillo y Rondana	4	-----	200092
4	Reductor de Velocidad	1	H-1020-00031	300031
5	Llave 5 x 20L	1	-----	300002
6	Tornillo M10 x 25L y Tornillo y Rondana	4	-----	200093
7	Soporte del Motor de Ajuste de 1.5M	1	-----	500034
8	Polea del Motor 10 cm (4") 22 de 1.5M	1	-----	500014
9	Set de Tornillos de Ajuste M8 x 10L	2	-----	200116
10	Tornillo M10 x 70L	1	-----	200095
11	Tornillo M6 x 12L y Rondana	1	-----	200077
12	Placa Fija para Caja del Motor	1	-----	500083
13	Perno	2	-----	500087
14	Anillo STW-10	2	-----	300006
15	Soporte para Plataforma Giratoria de 1.5M	1	-----	600000
16	Ensamble del Seguidor de Leva Incluye: • Anillo STW-17 #17 (4) • Balero 6203ZZ #18 (2) • Rueda Plástica de Soporte de 1.5M #19 (1) • Eje de Soporte de la Rueda Plástica de 1.5M #20 (1)	1	H-1020-CAM	700060
20	Anillo STW-17	1	H-1020-00009	300009
21	Balero 6203ZZ	1	H-1287-18	305300
22	Retén para Banda de Polea	1	H-1287-20	500011
23	Eje para Retén para Banda de Polea	1	H-1020-23	500012
24	Tornillo M6 x 16L	3	H-1020-M6X16	200078
25	Tornillo M3 x 25L y Rondana	2	-----	200098
26	Interruptor de Proximidad PS-05N-3M	1	H-1020-00641	400641
27	Soporte Fijo del Interruptor de Proximidad	1	H-1020FIXSET	500013
28	Tornillo M4 x 20L	2	-----	200103
29	Tuerca M5	6	-----	200128

MÁQUINA SEMIAUTOMÁTICA PARA PELÍCULA ELÁSTICA

CONTINUACIÓN DE LISTA DE PARTES DE LA PLATAFORMA GIRATORIA

#	DESCRIPCIÓN	CANT.	NO. DE PARTE DE ULINE	NO. DE PARTE DEL FABRICANTE
30	Banda B-172 de 1.5M	1	H-1020-00013	300013
31	Tornillo M8 x 25L	4	H-1020-M825L	200113
32	Placa de Plataforma Giratoria	1	H-1020-TPLT	500004
33	Tornillo M8 x 20L	4	H-1020-M820L	200084
34	Rueda de 55.88 cm (22")	1	H-1020-PLYDS	500007
35	Placa de Ubicación	1	H-1020-35	500006
36	Tornillo M5 x 10L y Rondana	4	-----	200108
37	Placa de Fijación de Polea	1	H-1287-34DS	500008
38	Anillo de Soporte para Banda de Polea	1	H-1287-BPSR	500085
39	Ensamble de Poste Rey Incluye: • Anillo RTW42 • Eje de la Polea de Correa • Balero 600422 • Anillo STW-20 • Asiento del Balero para Polea de Correa	1	H-2304-KING	700058
44	Tornillo M10 x 16L	4	H-1287-41	200088
45	Tornillo M4 x 8L y Rondana	4	-----	200100
46	Cubierta del Motor 1.5M	1	H-3700-MCVR	500081
47	Caja del Motor de la Plataforma Giratoria de 1.5M	1	H-1020-MTRBX	600028
48	Tornillo M4 x 8L y Rondana	2	-----	200100
	Cable de Corriente (No se Muestra)	1	H-1020-POWER	400743

**MÁQUINA SEMIAUTOMÁTICA
PARA PELÍCULA ELÁSTICA**800-295-5510
uline.mx

ENSAMBLE DE LA TORRE

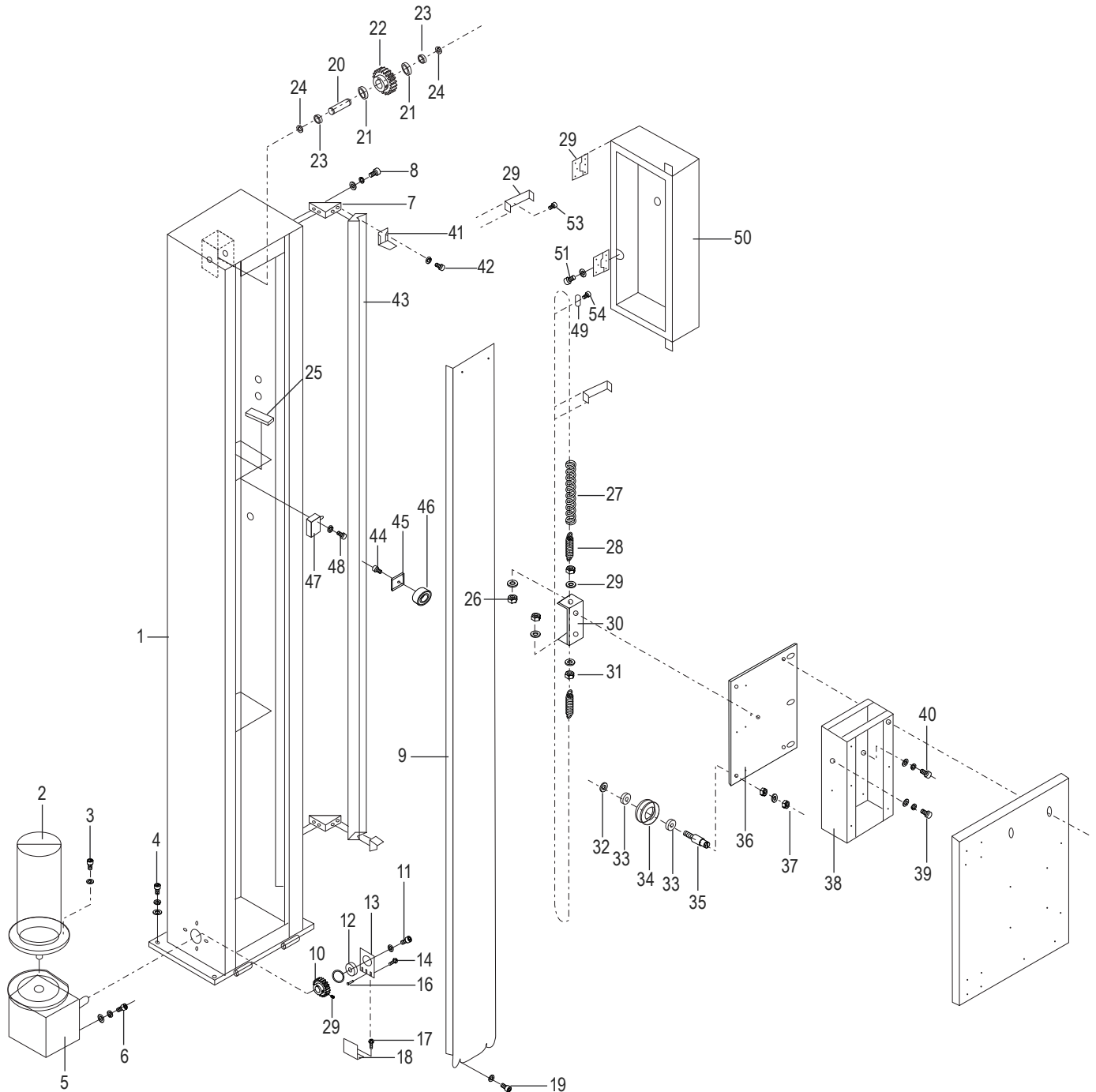

MÁQUINA SEMIAUTOMÁTICA PARA PELÍCULA ELÁSTICA

LISTA DE PARTES PARA ENSAMBLE DE LA TORRE

#	DESCRIPCIÓN	CANT.	NO. DE PARTE DE ULINE	NO. DE PARTE DEL FABRICANTE
1	Torre de 2.1M (For H-1020)	1	-----	500492
1	Torre de 2.6M (For H-1675)	1	-----	500134
2	Unidad del Motor de Elevación VP3310D	1	H-1675-00038	300038
3	Tornillo M8 x 20L y Tornillo	4	-----	200091
4	Tornillo M10 x 25L y Tornillo y Rondana	5	-----	200090
5	Reductor de de la Unidad de Elevación VTM 40	1	H-1020-REDUQ	300030
6	Tornillo M8 x 25L y Tornillo y Rondana	4	-----	200085
7	Soporte del Canal	2	H-3700-00135	500135
8	Tornillo M6 x 16L y Tornillo y Rondana	4	H-1020-M6X12	200078
9	Cubierta de Cadena de la Rueda 2.1M (For H-1020)	1	-----	500136
9	Cubierta de Cadena de la Rueda 2.6M (For H-1675)	1	-----	500137
10	Rueda (Inferior) para Cadena de 11 Dientes para Subir y Bajar	1	-----	500041
11	Tornillo con Cabeza Hueca M6 x 16L, Tornillo y Rondana	2	-----	200802
12	Balero 6202-2NR	1	-----	300020
13	Soporte del Balero del Reductor de Velocidad	1	-----	500102
14	Tornillo M4 x 6L y Rondana	2	-----	200099
15	Tornillo M6 x 8L	1	-----	200120
16	Perno 4 x 8	1	-----	300000
17	Tornillo M8 x 12L	2	-----	200082
18	Soporte del Balero de Ajuste	1	-----	500103
19	Tornillo M6 x 12L & W	4	H-1020-M6X12	200077
20	Eje Superior para Rueda de Cadena	1	-----	500003
21	Balero 6002ZZ	2	-----	300017
22	Rueda Superior para Cadena	1	-----	500118
23	Anillo	2	-----	500093
24	Anillo STW-15	2	-----	300008
25	Rondana para Barra de Ajuste	1	-----	501864
26	Tuerca M12	1	-----	200140
27	Cadena de 2.1M (Para H-1020)	1	H-1020-2.1M	300049
27	Cadena de 2.6M (Para H-1675)	1	-----	300050
28	Tornillo de Eje para Cadena de Unidad de Elevación	2	-----	500025
29	Rondana M12	4	-----	200147
30	Soporte de Cadena de Ajuste	1	-----	500092
31	Tuerca M12	3	-----	200133
32	Anillo STW-12	6	-----	300007
33	Balero 6001ZZ	8	-----	300016
34	Rueda de Dirección para Subir y Bajar	4	-----	500090

MÁQUINA SEMIAUTOMÁTICA PARA PELÍCULA ELÁSTICA

CONTINUACIÓN DE LISTA DE PARTES PARA ENSAMBLE DE LA TORRE

#	DESCRIPCIÓN	CANT.	NO. DE PARTE DE ULINE	NO. DE PARTE DEL FABRICANTE
35	Eje de la Rueda de Dirección para Subir y Bajar	4	-----	500091
36	Soporte de Rueda para Cadena	1	-----	500040
37	Tuerca M10 y Tornillo y Rondana	6	-----	200131
38	Soporte (Interior) de Unidad de Elevación	1	-----	600008
39	Tornillo M8 x20L y Tornillo y Rondana	2	H-1020-M820L	200084
40	Tornillo M8 x 16L y Tornillo y Rondana	6	-----	200083
41	Placa de Límite	2	-----	500138
42	Tornillo M6 y 16L y Tornillo y Rondana	4	-----	200125
43	Canal de 2.1M (Para H-1020)	1	H-3700-00139	500139
43	Canal de 2.6M (Para H-1675)	1	-----	500140
44	Tornillo M6 x 16L	1	H-1020-M6X16	200078
45	Pieza Fija	1	H-1020-FIXPC	500141
46	Rueda del Asa	1	H-1020-HNDWH	500142
47	Interruptor de Límite TZ-7110	1	H-1020-00637	400637
48	Tornillo M4 x 30L y Rondana	2	-----	200105
49	Candado con Llave	2	-----	300015
50	Caja de Control	1	H-1020-00143	500143
50a	Etiqueta de Membrana del Botón para Panel de Control	1	H-1020-LBL	310008
51	Tornillo M6 y 10L y Tornillo	1	-----	200076
52	Placa para Pestillo de Candado	2	-----	300048
53	Tornillo M6 x 10L y Tornillo	4	H-2957-MSCRW	200766
54	Tornillo M5 x 16L	1	-----	204905
55	Bisagra	2	-----	500106
	Llave (No se Muestra)	2	H-1020-KEYS	300046
	Cerradura con Llave (No se Muestra)	2	H-1020TWRKEY	300041
	Ventilador (No se Muestra)	1	H-1020-FAN	403567

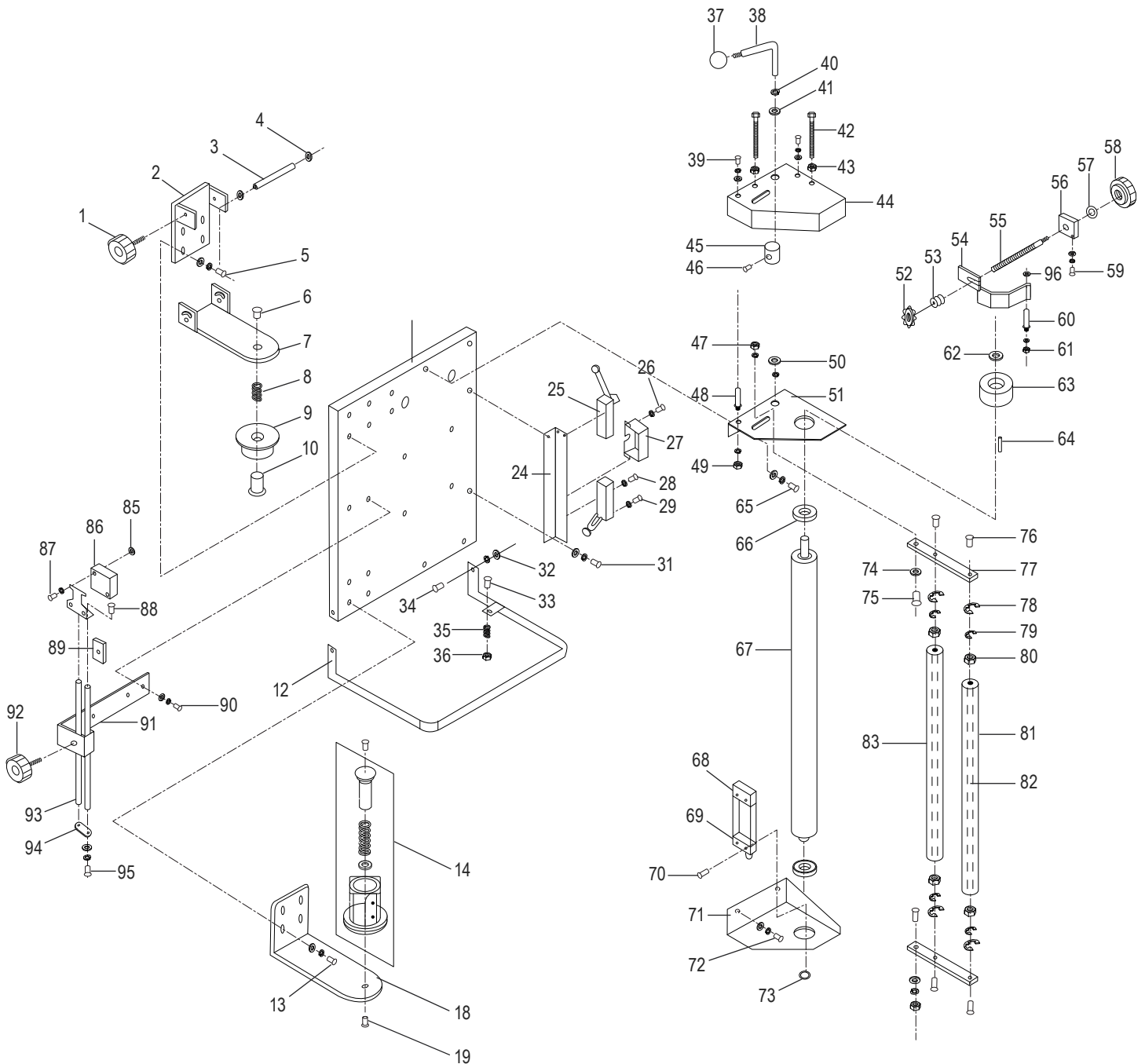
**MÁQUINA SEMIAUTOMÁTICA
PARA PELÍCULA ELÁSTICA**800-295-5510
uline.mx**ENSAMBLE DEL PORTADOR DE LA PELÍCULA**

MÁQUINA SEMIAUTOMÁTICA PARA PELÍCULA ELÁSTICA

LISTA DE PARTES DEL PORTADOR DE LA PELÍCULA

#	DESCRIPCIÓN	CANT.	NO. DE PARTE DE ULINE	NO. DE PARTE DEL FABRICANTE
1	Asa	1	H-1020HANDLE	500000
1a	Asa	1	H-1020HANDLE	500000
1b	Varilla Roscada de Perilla	1	-----	204908
2	Soporte Fijo para Película (Superior)	1	-----	500144
3	Eje	1	-----	500145
4	Anillo STW-10	2	-----	300006
5	Tornillo M6 x 20L y Tornillo y Rondana	4	-----	200079
6	Tornillo M10 x 20L	1	H-2957-FHCS	200627
7	Eje Móvil para Película	1	-----	500146
8	Resorte del Soporte para Película	1	-----	500147
9	Soporte para Película (Superior)	1	-----	500148
10	Eje del Soporte para Película	1	-----	500101
11	Asiento de Unidad del Elevador (Exterior) – 20"	1	-----	500149
11	Asiento de Unidad del Elevador (Exterior) – 30"	1	-----	504260
12	Pedal	1	H-1020-FTPED	500150
13	Tornillo M6 x 20L y Tornillo y Rondana	4	-----	200079
14	Ensamble del Soporte Inferior del Núcleo Incluye: • Eje del Asiento de la Película • Resorte • Balero NTB/A51730 • Soporte del Núcleo de la Película • Placa del Freno del Núcleo de la Película • Disco de Freno de la Película • Rondana	1	H-1619-LCORE	700072
18	Soporte Fijo para Película (Inferior)	1	-----	500151
19	Tornillo M10 x 20L	1	-----	200089
24	Soporte del Interruptor de Límite	1	-----	500152
25	Interruptor de Límite TZ-8108	2	H-1020-00639	400639
26	Tornillo M4 x 12L	2	-----	200101
27	Cubierta de Terminal	1	-----	500130
28	Tornillo M4 x 16L	4	-----	200102
29	Tornillo M4 x 12L	4	-----	200101
31	Tornillo M6 x 12L y Tornillo y Rondana	2	H-1020-M6X12	200077
32	Tuerca M6	2	-----	200137
33	Tornillo M6 x 20L	1	-----	200103
34	Tornillo M6 x 20L	2	-----	200079
35	Resorte	1	-----	500016
36	Tuerca M4	2	-----	200127
37	Perilla del Asa	1	H-1020HANDLE	500913
38	Asa	1	-----	500153

MÁQUINA SEMIAUTOMÁTICA PARA PELÍCULA ELÁSTICA

CONTINUACIÓN DE LISTA DE PARTES DEL PORTADOR DE LA PELÍCULA

#	DESCRIPCIÓN	CANT.	NO. DE PARTE DE ULINE	NO. DE PARTE DEL FABRICANTE
39	Tornillo M6 x 12L y Tornillo y Rondana	2	H-1020-M6X12	200077
40	Anillo STW-10	1	-----	300006
41	Anillo	1	-----	500154
42	Tornillo M6 x 100L	2	-----	200157
43	Tuerca M6	4	-----	200129
44	Cubierta del Soporte de la Película	1	-----	500155
45	Rueda	1	-----	500156
46	Tornillo M6 x 10L	1	-----	200121
47	Tuerca M8 y Tornillo	2	-----	200130
48	Eje del Soporte de Película	1	-----	500157
49	Tuerca M8 y Rondana	1	-----	200130
50	Anillo	1	-----	500158
51	Soporte Superior para Película	1	-----	500159
52	Soporte del Ajuste de Tensión	1	-----	500160
53	Resorte	1	H-1020-SPRNG	500161
54	Placa del Freno	1	H-1020-00162	500162
55	Tornillo del Ajuste de Tensión	1	H-1020-BSCRW	500163
56	Tornillo de Engrane del Soporte Fijo	1	-----	500164
57	Anillo	1	-----	500154
58	Asa	1	H-1020HANDLE	500000
59	Tornillo M6 x 12L y Tornillo y Rondana	2	H-1020-M6X12	200077
60	Eje de Placa de Freno	1	-----	500165
61	Tuerca M6 y Tornillo	2	-----	200129
62	Eje Fijo de Rueda del Freno	1	-----	500166
63	Rueda de Freno	1	-----	500167
64	Perno 5 x 5 x 20L	1	-----	300002
65	Tornillo M8 x 20L y Tornillo y Rondana	2	H-1020-M820L	200084
66	Balero 6004ZZ-NR	2	H-1020-BEARN	300051
67	Eje Preestirado - 20"	1	H-1020-PSHFT	500168
67	Eje Preestirado - 30"	1	-----	504261
68	Protector de Cable	1	-----	400640
69	Interruptor de Límite TM-1307	1	H-1020-00636	400636
70	Tornillo M4 x 25L	2	-----	200104
71	Soporte Inferior para Película	1	-----	500169
72	Tornillo M8 x 20L y Tornillo y Rondana	2	H-1020-M820L	200084
73	Anillo STW-20	1	H-1287-STW20	300010
74	Anillo	2	-----	500158
75	Perno del Eje Móvil	2	-----	500170
76	Tornillo M6 x 12L	4	H-1020-76	200833

MÁQUINA SEMIAUTOMÁTICA PARA PELÍCULA ELÁSTICA

CONTINUACIÓN DE LISTA DE PARTES DEL PORTADOR DE LA PELÍCULA

#	DESCRIPCIÓN	CANT.	NO. DE PARTE DE ULINE	NO. DE PARTE DEL FABRICANTE
77	Eje Móvil (Para H-1020)	1	-----	500171
77	Eje Móvil (Para H-1675)	1	-----	500172
78	Anillo STW-22	4	H-1020-78	300052
79	Anillo STW-10	4	H-1020-79	300006
80	Balero 6000ZZ	4	H-1020-80	300015
81	Rodillo Loco - 30"	1	H-1020-81	504262
82	Eje de Rodillo Loco - 20"	2	H-1020-82	500174
82	Eje de Rodillo Loco - 30"	2	-----	504263
83	Rodillo Loco - 20"	1	-----	500175
83	Rodillo Loco - 30"	1	-----	504264
85	Tuerca M4 (Opción)	2	-----	200127
86	Foto Sensor (Opción)	1	H-1020-00643	400643
87	Tornillo M4 x 12L y Rondana (Opción)	2	-----	200101
88	Screw M6 x 12L (Opción)	2	-----	200110
89	Pieza Fija (Opción)	1	-----	500094
90	Tornillo M6 x 20L y Tornillo y Rondana (Opción)	2	-----	200079
91	Soporte de Ajuste del Foto Sensor (Opción)	1	-----	500176
92	Asa (Opción)	1	H-1020HANDLE	500000
93	Soporte de Ajuste del Foto Sensor (Opción)	2	-----	500095
94	Placa de Conexión	1	-----	500096
95	Tornillo M6 x 12L y Tornillo y Tuerca (Opción)	2	H-1020-M6X12	200077
96	Espaciador Antichirrido	1	-----	304629
	Freno (No se Muestra)	1	-----	500111
	Placa del Freno de la Película (No se Muestra)	1	-----	500109
	Soporte Fijo de la Película (No se Muestra)	1	-----	500107
	Tornillo M6 x 20L y Tornillo y Rondana (No se Muestra)	2	-----	200079
	Rondana (No se Muestra)	1	-----	500112

ULINE H-1020, H-1619
H-1675, H-7208

DISTRIBUTEUR DE FILM ÉTIRABLE SEMI-AUTOMATIQUE

1-800-295-5510
uline.com

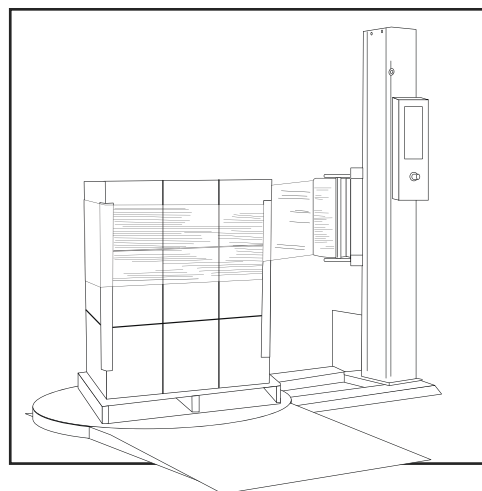

Liste des pièces du système électrique

DESCRIPTION	QTÉ	RÉF. ULINE	RÉF. DU FABRICANT
Carte à microprocesseur	1	H-1020-CARD	401495
Carte de transformateur	1	H-1020-TRANS	401361
Fusible, 250 V c.a., 1 A, GMA	2	H-1020-01362	401362
Fusible, 250 V c.a., 10 A, GMA	2	H-1020-03261	403261
Fusible, 250 V c.a., 5 A, GMA	2	H-1020-01365	401365
Relais LY2 24 V c.c.	5	H-1020-00630	401366
Bouton, blanc	1	H-1020-01367	401367
Bouton contacteur de la portée Nox1	1	-----	401368
Voyant vert à exécution automatique : Couvercle	1	H-1020GSB	400609
Voyant vert à exécution automatique : Siège	1	-----	400610
Voyant vert à exécution automatique : Voyant	1	H-1020-00611	400611
Bouton RN-99F, 6,4 Ø	2	H-1020-01371	401371
Résistances diverses 5K	2	-----	400649
EMG. Interrupteur	1	-----	401372
Bouton contacteur de la portée NCx1	1	H-1020-01373	401373
Interrupteur d'alimentation principale	1	H-1020-PWRSW	401374
Interrupteur de fin de course TZ-8108	2	H-1020-00639	400639
Interrupteur de fin de course TM-1307	1	H-1020-00636	400636
Détecteur de proximité PS-05N-3M	1	H-1020-00641	400641
Interrupteur de fin de course TZ-7110	1	H-1020-00637	400637
Détecteur optique A3R-2MX (optionnel)	1	H-1020-00643	400643
Ventilateur, 80 mm (3,15 po), 110 à 120 V c.a.	1	H-1020-04261	404261
Porte-fusible	1	H-1020-04262	404262
Fusible, 0,2 A, 30 mm (1,18 po)	1	H-1020-04263	404263
Étiquette de bouton membrane pour panneau de commande	1	H-1020-LBL	310008
Câble de commande du chariot	1	H-1020-CNTRL	403409

DISTRIBUTEUR DE FILM ÉTIRABLE SEMI-AUTOMATIQUE

ASSEMBLAGE DU CADRE DE LA PLAQUE TOURNANTE

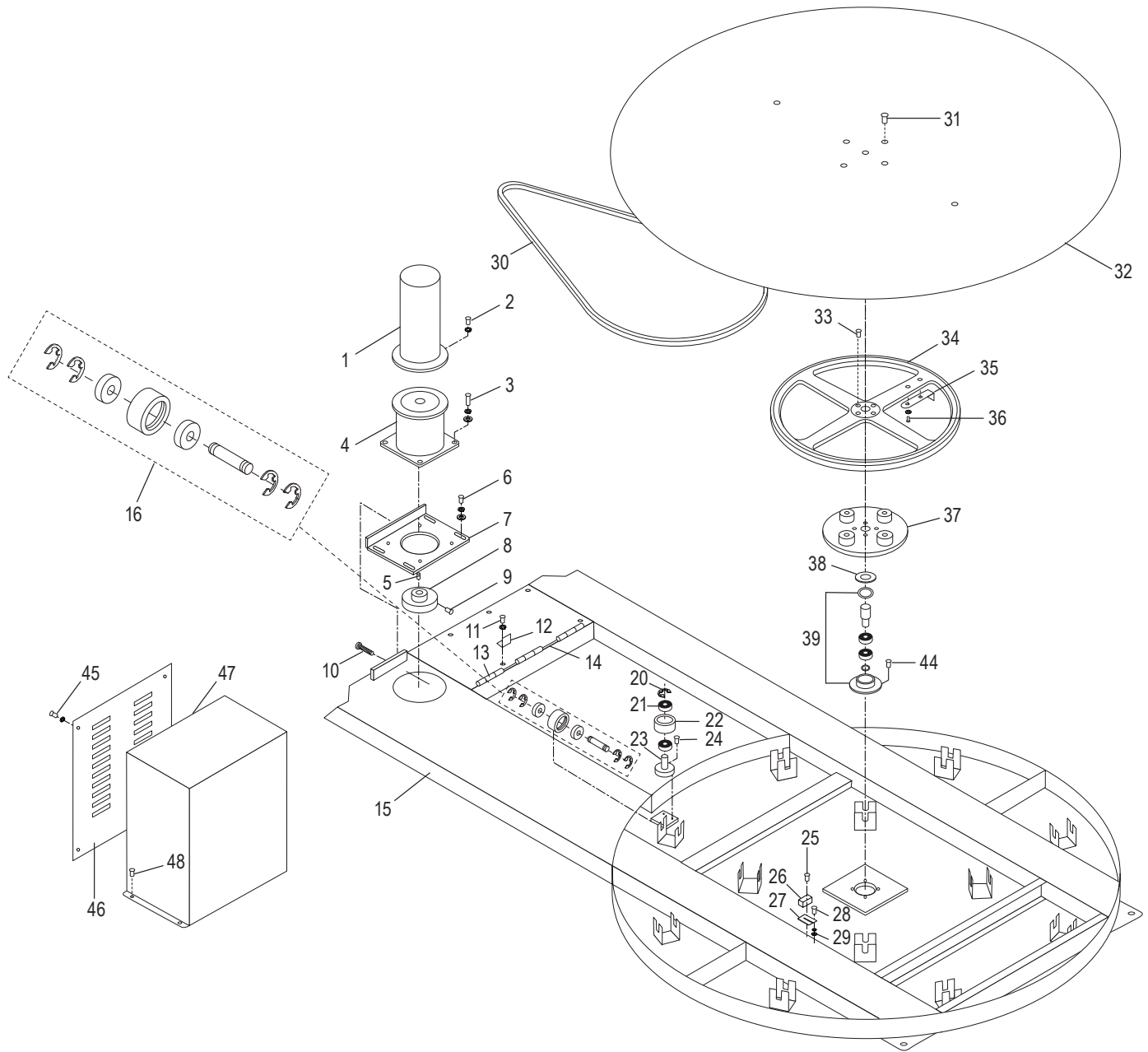

**DISTRIBUTEUR
DE FILM ÉTIRABLE
SEMI-AUTOMATIQUE**

**LISTE DES PIÈCES DU CADRE DE
LA PLAQUE TOURNANTE**

#	DESCRIPTION	QTÉ	RÉF. ULINE	RÉF. DU FABRICANT
1	Moteur	1	H-1020-37	300037
2	Vis M8 x 20L & W	4	-----	200091
3	Vis M10 x 20L & SW & W	4	-----	200092
4	Réducteur de vitesse	1	H-1020-00031	300031
5	Clavette 5 x 20L	1	-----	300002
6	Vis M10 x 25L & SW & W	4	-----	200093
7	Portée de réglage moteur 1.5M	1	-----	500034
8	Poulie du moteur 10 cm (4 po) 22 1.5M	1	-----	500014
9	Vis de réglage M8 x 10L	2	-----	207303
10	Vis M10 x 70L	1	-----	200095
11	Vis M6 x 12L & W	1	H-1020-M6X12	200077
12	Plaque de fixation de la boîte de moteur	1	-----	500083
13	Broche	2	-----	500087
14	Bague STW-10	2	-----	300006
15	Portée de la plaque tournante 1.5M	1	-----	600000
16	L'ensemble de galet suiveur inclus: • Bague STW-17 #17 (4) • Roulement 6203ZZ #18 (2) • Roue de support en plastique 1.5M #19 (1) • Arbre de la roue de support en plastique 1.5M #20 (1)	1	H-1020-CAM	700060
20	Bague STW-17	1	H-1020-00009	300009
21	Roulement 6203ZZ	2	H-1287-18	305300
22	Poulie de verrouillage de courroie	1	H-1287-20	500011
23	Arbre de la poulie de verrouillage de courroie	1	H-1020-23	500012
24	Vis M6 x 16L	3	H-1020-M6X16	200078
25	Vis M3 x 25L & W	2	-----	200098
26	Détecteur de proximité PS-05N-3M	1	H-1020-00641	400641
27	Portée de fixation du détecteur de proximité	1	H-1020FIXSET	500013
28	Vis M4 x 20L	2	-----	200103
29	Écrou M5	6	-----	200128

**DISTRIBUTEUR
DE FILM ÉTIRABLE
SEMI-AUTOMATIQUE**

LISTE DES PIÈCES DU CADRE
DE LA PLAQUE TOURNANTE, SUITE

#	DESCRIPTION	QTÉ	RÉF. ULINE	RÉF. DU FABRICANT
30	Courroie B-172 1.5M	1	H-1020-00013	300013
31	Vis M8 x 25L	4	H-1020-M825L	200113
32	Plateau de la plaque tournante 1.5M	1	H-1020-TPLT	500004
33	Vis M8 x 20L	4	H-1020-M820L	200084
34	Roue de 56 cm (22 po)	1	H-1020-PLYDS	500007
35	Plaque de localisation	1	H-1020-35	500006
36	Vis M5 x 10L & W	4	-----	200108
37	Plaque de fixation à la poulie	1	H-1287-34DS	500008
38	Bague de la portée de poulie à courroie	1	H-1287-BPSR	500085
39	Assemblage du montant L'ensemble comprend : • Bague RTW42 • Arbre de la poulie à courroie • Roulement 600422 • Bague STW-20 • Portée de roulement de la poulie à courroie	1	H-2304-KING	700058
44	Vis M10 x 16L	4	H-1287-41	200088
45	Vis M4 x 8L & W	4	-----	200100
46	Couvercle du moteur 1.5M	1	H-3700-MCVR	500081
47	Boîte de moteur de la plaque tournante 1.5M	1	H-1020-MTRBX	600028
48	Vis M4 x 8L & W	2	-----	200100
	Cordon d'alimentation (non illustré)	1	H-1020-POWER	400743

DISTRIBUTEUR DE FILM ÉTIRABLE SEMI-AUTOMATIQUE

MONTAGE DE LA TOUR

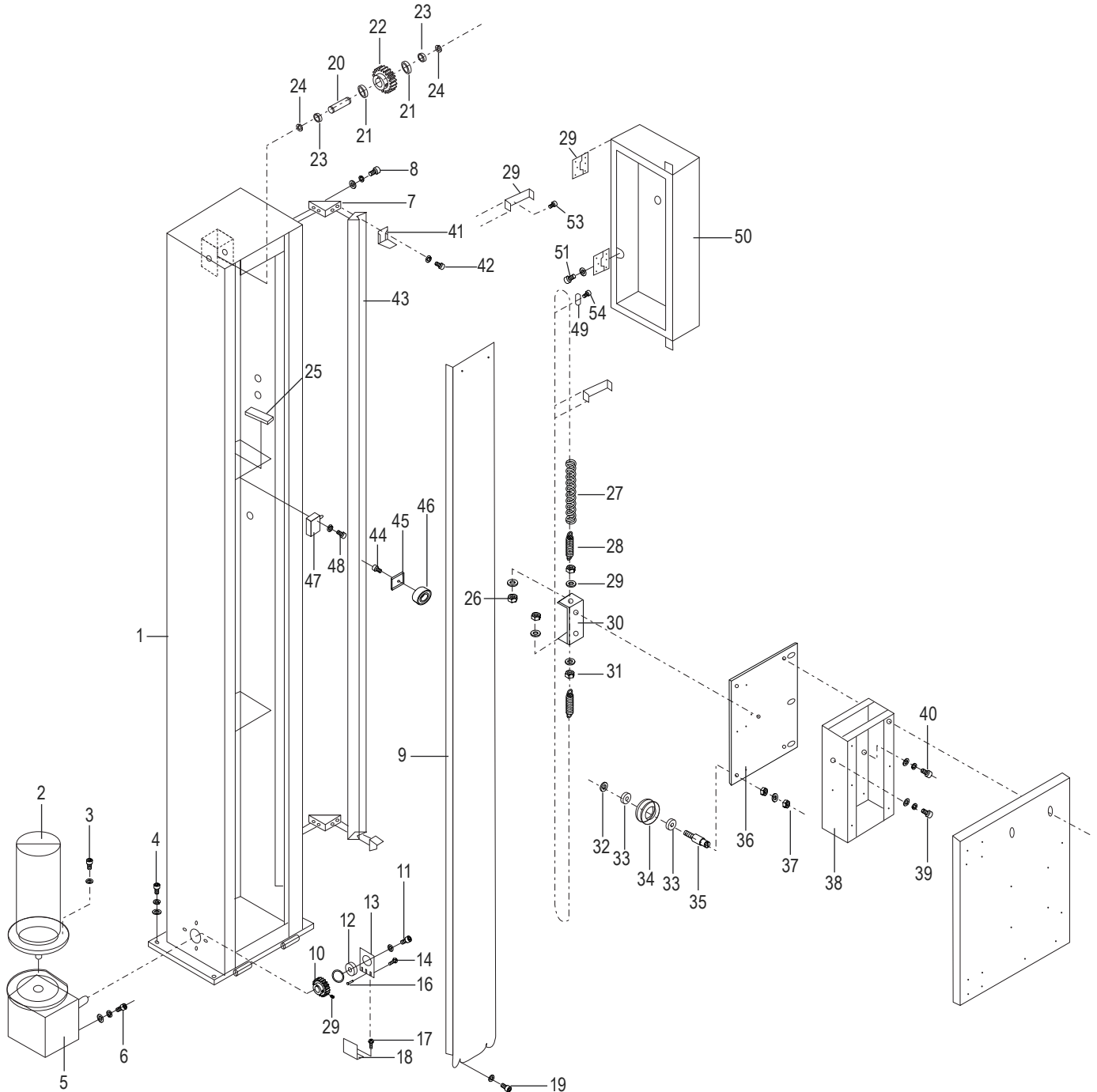

**DISTRIBUTEUR
DE FILM ÉTIRABLE
SEMI-AUTOMATIQUE**

LISTE DES COMPOSANTS DE LA TOUR

#	DESCRIPTION	QTÉ	RÉF. ULINE	RÉF. DU FABRICANT
1	Tour 2.1M (pour H-1020)	1	-----	500492
1	Tour 2.6M (pour H-1675)	1	-----	500134
2	Moteur d'ascenseur VP3310D	1	H-1675-00038	300038
3	Vis M8 x 20L & SW	4	-----	200091
4	Vis M10 x 25L & SW & W	5	-----	200090
5	Réducteur de vitesse de l'ascenseur VTM-40	1	H-1020-REDUQ	300030
6	Vis M8 x 25L & SW & W	4	-----	200085
7	Support du profil	2	H-3700-00135	500135
8	Vis M6 x 16L & SW & W	4	H-1020-M6X16	200078
9	Couvercle de la roue pour transmission par chaîne 2,1M (pour H-1020)	1	-----	500136
9	Couvercle de la roue pour transmission par chaîne 2,6M (pour H-1675)	1	-----	500137
10	Roue pour transmission par chaîne haut et bas à 11 dents (en bas)	1	-----	500041
11	SHCS, M6 x 16L & SW & W	2	-----	200802
12	Roulement 6202-2NR	1	-----	300020
13	Portée de roulement du réducteur de vitesse	1	-----	500102
14	Vis, M4 x 6L & W	2	-----	200099
15	Vis M6 x 8L	1	-----	200120
16	Broche de raccordement 4 x 8	1	-----	300000
17	Vis M8 x 12L	2	-----	200082
18	Portée de roulement de réglage	1	-----	500103
19	Vis M6 x 12L & W	4	H-1020-M6X12	200077
20	Arbre de roue de chaîne supérieure	1	-----	500003
21	Roulement 6002ZZ	2	-----	300017
22	Roue pour transmission par chaîne supérieure	1	-----	500118
23	Bague	2	-----	500093
24	Bague STW-15	2	-----	300008
25	Rondelle de la barre de réglage	1	-----	501864
26	Écrou M12	1	-----	200140
27	Chaîne 2.1M (pour H-1020)	1	H-1020-2.1M	300049
27	Chaîne 2.6M (pour H-1675)	1	-----	300050
28	Tige des vis de la chaîne de l'ascenseur	2	-----	500025
29	Rondelle M12	4	-----	200147
30	Portée de réglage de la chaîne	1	-----	500092
31	Écrou M12	3	-----	200133
32	Bague STW-12	6	-----	300007
33	Roulement 6001ZZ	8	-----	300016
34	Roue d'entraînement haut et bas	4	-----	500090

**DISTRIBUTEUR
DE FILM ÉTIRABLE
SEMI-AUTOMATIQUE**

LISTE DES COMPOSANTS DE LA TOUR, SUITE

#	DESCRIPTION	QTÉ	RÉF. ULINE	RÉF. DU FABRICANT
35	Arbre de la roue d'entraînement haut et bas	4	-----	500091
36	Portée de la roue à chaîne	1	-----	500040
37	Écrou M10 & SW & W	6	-----	200131
38	Portée de l'ascenseur (intérieur)	1	-----	600008
39	Vis M8 x 20L & SW & W	2	H-1020-M820L	200084
40	Vis M8 x 16L & SW & W	6	-----	200083
41	Plaque de limitation	2	-----	500138
42	Vis M6 x 16L & SW & écrou	4	-----	200125
43	Profilé 2.1M (pour H-1020)	1	H-3700-00139	500139
43	Profilé 2.6M (pour H-1675)	1	-----	500140
44	Vis M6 x 16L	1	H-1020-M6X16	200078
45	Pièce de fixation	1	H-1020-FIXPC	500141
46	Roue de la poignée	1	H-1020-HNDWH	500142
47	Interrupteur de fin de course TZ-7110	1	H-1020-00637	400637
48	Vis M4 x 30L & W	2	-----	200105
49	Serrure à clé	2	-----	300015
50	Boîte de commande	1	H-1020-00143	500143
50a	Étiquette du bouton membrane pour panneau de commande	1	H-1020-LBL	310008
51	Vis M6 x 10L & SW	1	-----	200076
52	Plaque de verrouillage	2	-----	300048
53	Vis, M6 x 10L & SW	4	H-2957-MSCRW	200766
54	Vis, M5 x 16L	1	-----	204905
55	Charnière	2	-----	500106
	Clé (non illustré)	2	H-1020-KEYS	300046
	Serrure à clé (non illustré)	2	H-1020TWRKEY	300041
	Ventilateur (non illustré)	1	H-1020-FAN	403567

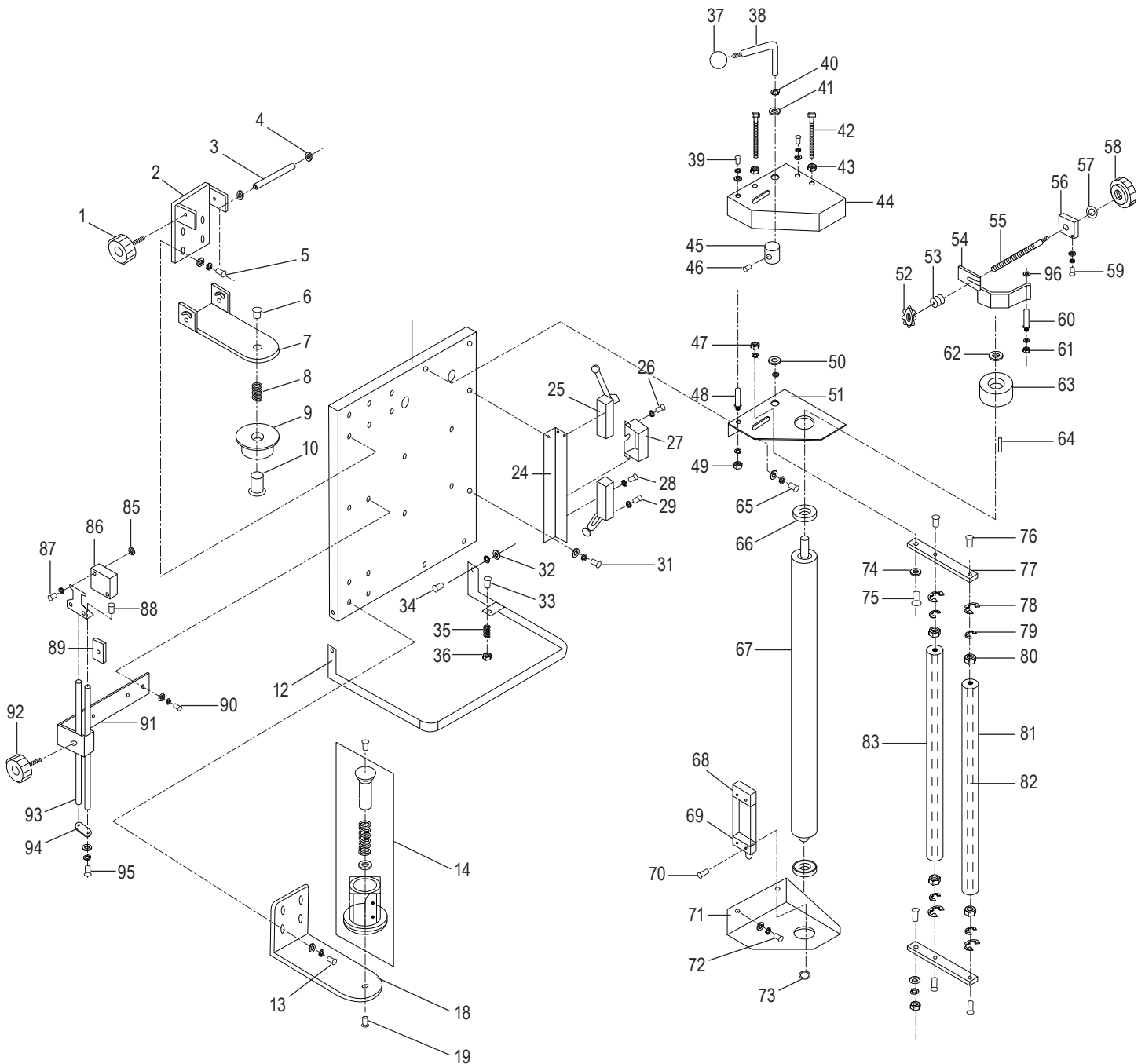
**DISTRIBUTEUR
DE FILM ÉTIRABLE
SEMI-AUTOMATIQUE****ASSEMBLAGE DU CHARIOT PORTE-FILM**

DISTRIBUTEUR DE FILM ÉTIRABLE SEMI-AUTOMATIQUE

Liste des pièces du chariot porte-film

#	DESCRIPTION	QTÉ	RÉF. ULINE	RÉF. DU FABRICANT
1a	Poignée	1	H-1020HANDLE	500000
1b	Tige filetée pour poignée	1	-----	204908
2	Portée de fixation du film (haut)	1	-----	500144
3	Arbre	1	-----	500145
4	Bague STW-10	2	-----	300006
5	Vis M6 x 20L & SW & W	4	-----	200079
6	Vis M10 x 20L	1	H-2957-FHCS	200627
7	Arbre mobile du film	1	-----	500146
8	Ressort de la portée du film	1	-----	500147
9	Portée du film (haut)	1	-----	500148
10	Arbre de la portée du film	1	-----	500101
11	Portée de l'ascenseur (extérieur) – 20 po	1	-----	500149
11	Portée de l'ascenseur (extérieur) – 30 po	1	-----	504260
12	Pédale	1	H-1020-FTPED	500150
13	Vis M6 x 20L & SW & W	4	-----	200079
14	Assemblage du support inférieur du mandrin L'ensemble comprend : • Arbre de la portée du film • Ressort • Roulement NTB/A51730 • Support du mandarin du film • Plaque de freinage du mandrin du film • Disque de freinage du film • Rondelle	1	H-1619-LCORE	700072
18	Portée du film (inférieur)	1	-----	500151
19	Vis M10 x 20L	1	-----	200089
24	Portée de l'interrupteur de fin de course	1	-----	500152
25	Interrupteur de fin de course TZ-8108	2	H-1020-00639	400639
26	Vis M4 x 12L	2	-----	200101
27	Capot	1	-----	500130
28	Vis M4 x 16L	4	-----	200102
29	Vis M4 x 12L	4	-----	200101
31	Vis M6 x 12L & SW & W	2	H-1020-M6X12	200077
32	Écrou M6	2	-----	200137
33	Vis M4 x 20L	1	-----	200103
34	Vis M6 x 20L	2	-----	200079
35	Ressort	1	-----	500016
36	Écrou M4	2	-----	200127
37	Bouton de la poignée	1	H-1020HANDLE	500913
38	Poignée	1	-----	500153

**DISTRIBUTEUR
DE FILM ÉTIRABLE
SEMI-AUTOMATIQUE**

LISTE DES PIÈCES DU CHARIOT PORTE-FILM, SUITE

#	DESCRIPTION	QTÉ	RÉF. ULINE	RÉF. DU FABRICANT
39	Vis M6 x 12L & SW & W	2	-----	200077
40	Bague STW-10	1	-----	300006
41	Bague	1	-----	500154
42	Vis M6 x 100L	2	-----	200157
43	Écrou M6	4	-----	200129
44	Housse extensible	1	-----	500155
45	Roue	1	-----	500156
46	Vis M6 x 10L	1	-----	200121
47	Écrou M8 & SW	2	-----	200130
48	Arbre de portée d'allongement	1	-----	500157
49	Écrou M8 & W	1	-----	200130
50	Bague	1	-----	500158
51	Portée d'allongement supérieure	1	-----	500159
52	Portée de réglage de tension	1	-----	500160
53	Ressort	1	H-1020-SPRNG	500161
54	Plaque de freinage	1	H-1020-00162	500162
55	Vis de réglage de tension	1	H-1020-BSCRW	500163
56	Portée de fixation à vis	1	-----	500165
57	Bague	1	-----	500154
58	Poignée	1	-----	500000
59	Vis M6 x 12L & SW & W	2	-----	200077
60	Arbre du disque de pause	1	-----	500165
61	Écrou M6 & SW	2	-----	200129
62	Arbre de fixation de la roue de pause	1	-----	500166
63	Roue de pause	1	-----	500167
64	Goupille 5 x 5 x 20 L	1	-----	300002
65	Vis M8 x 20L & SW & W	2	-----	200084
66	Roulement 6004ZZ-NR	2	H-1020-BEARN	300051
67	Arbre de préallongement – 20 po	1	H-1020-PSHFT	500168
67	Arbre de préallongement – 30 po			
68	Protège-câble	1	-----	400640
69	Interrupteur de fin de course TM-1307	1	H-1020-00636	400636
70	Vis M4 x 25L	2	-----	200104
71	Portée d'allongement inférieure	1	-----	500169
72	Vis M8 x 20L & SW & W	2	-----	200084
73	Bague STW-20	1	-----	300010
74	Bague	2	-----	500158
75	Tige de arbre mobile	2	-----	500170
76	Vis, M6 x 12L	4	H-1020-76	200833

**DISTRIBUTEUR
DE FILM ÉTIRABLE
SEMI-AUTOMATIQUE**

LISTE DES PIÈCES DU CHARIOT PORTE-FILM, SUITE

#	DESCRIPTION	QTÉ	RÉF. ULINE	RÉF. DU FABRICANT
77	Arbre mobile (pour H-1020)	1	-----	500171
77	Arbre mobile (pour H-1675)	1	-----	500172
78	Bague STW-22	4	H-1020-78	300052
79	Bague STW-10	4	H-1020-79	300006
80	Roulement 6000ZZ	4	H-1020-80	300015
81	Rouleau libre – 30 po	1	H-1020-81	500173
82	Arbre du rouleau libre – 20 po	2	H-1020-82	500174
82	Arbre du rouleau libre – 30 po	1	-----	500175
83	Rouleau libre – 20 po			
83	Rouleau libre – 30 po			
85	Écrou M4 (en option)	2	-----	200127
86	Détecteur optique (en option)	1	H-1020-00643	400643
86	Détecteur de couleur optique (en option)	1	H-1020-COLOR	700863
87	Vis M4 x 12L & W (en option)	2	-----	200101
88	Vis M6 x 12L (en option)	2	-----	200110
89	Pièce de fixation (en option)	1	-----	500094
90	Vis M6 x 20L & SW & W (en option)	2	-----	200079
91	Portée de réglage du détecteur optique (en option)	1	-----	500176
92	Pilote (en option)	1	-----	500000
93	Barre de réglage du détecteur optique (en option)	2	-----	500095
94	Plaque de raccordement (en option)	1	-----	500096
95	Vis M6 x 12L & SW & W (en option)	2	-----	200077
96	Entretoise, anti-bruit			
	Frein (non illustré)	1	-----	500111
	Plaque de freinage du film (non illustré)	1	-----	500109
	Portée du film (non illustré)	1	-----	500107
	Vis M6 x 20L & SW & W (non illustré)	2	-----	200079
	Rondelle (non illustré)	1	-----	500112