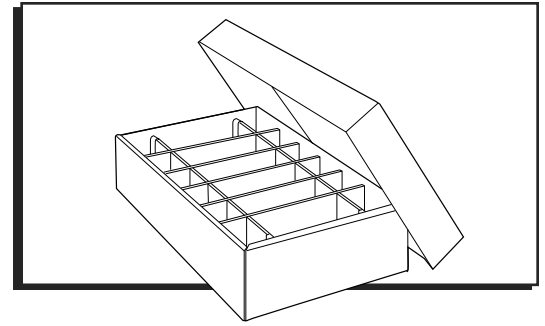


**ULINE** S-18439

**CORSTAT™**  
**IN-PLANT HANDLER –**  
**17 x 10 x 4"**

1-800-295-5510  
uline.com



## BOX ASSEMBLY

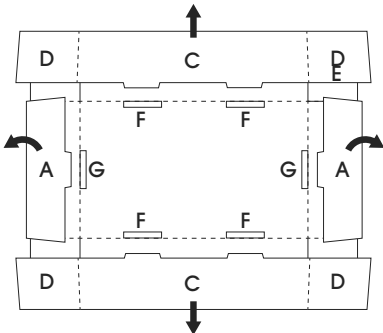


Figure 1

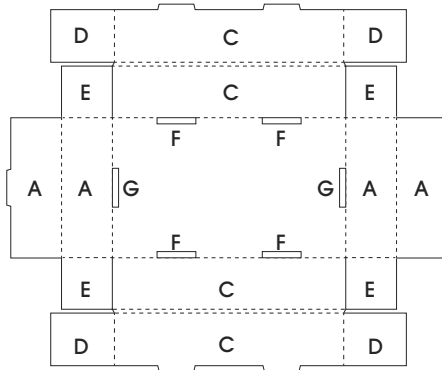


Figure 2

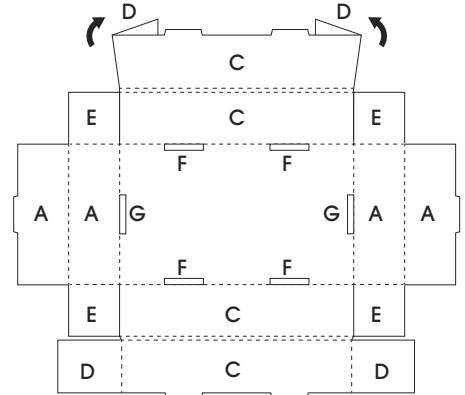


Figure 3

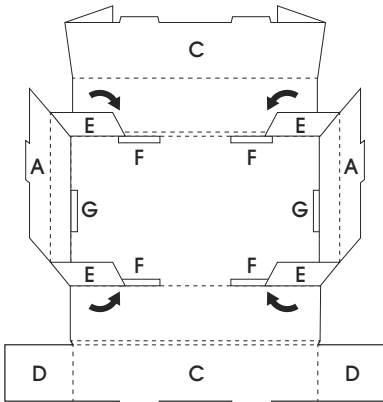


Figure 4

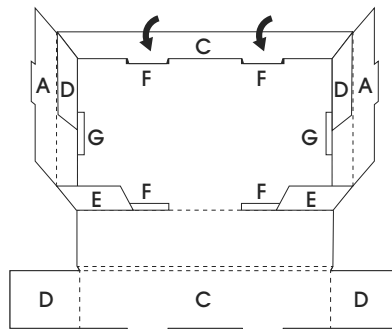


Figure 5

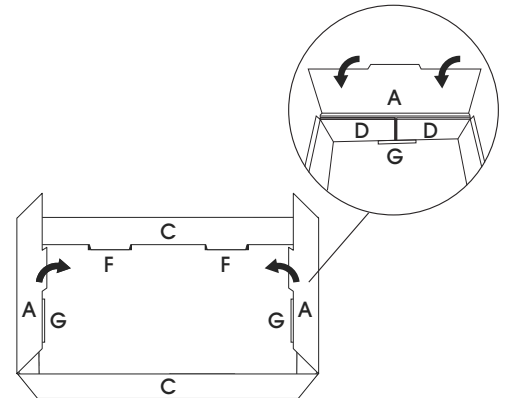


Figure 6

1. Place unassembled box on a flat surface with flaps facing up. (See Figure 1)
2. Unfold all flaps. (See Figure 2)
3. On one side, fold side flaps (D) outward. (See Figure 3)
4. On the shorter side of the box, fold in all four side flaps (E) over slots (F). (See Figure 4)
5. Fold side panel (C) over side flaps (E). Make sure side flaps (D) are folded outward and against side panel (A). (See Figure 5)
6. Lock the side panel tabs (C) into slots (F). (See Figure 6)
7. Repeat steps 3-6 for the other side.
8. Fold side flap (A) over side flaps (D), locking the side flap tab (A) into slots (G). (See Figure 6)
9. Repeat step 8 for the other side.
10. Box is assembled. (See Figure 7)

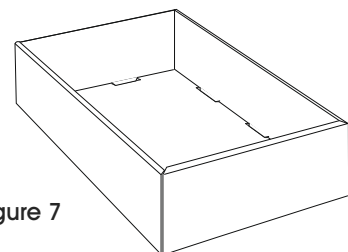


Figure 7

## BOX LID ASSEMBLY

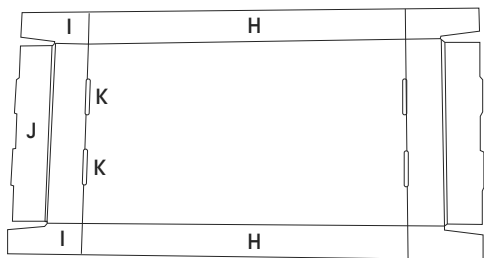


Figure 8

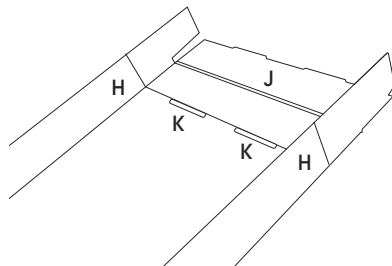


Figure 9

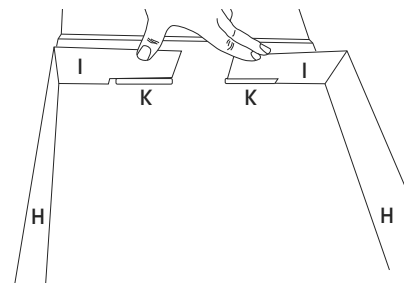


Figure 10

1. Fold lid sides (H) along the crease. (See Figures 8-9)
2. On one side of the box lid, fold in lid sides (I) over slots (K). (See Figure 10)

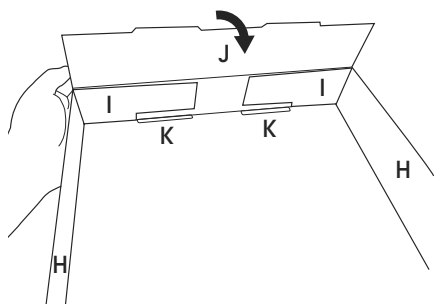


Figure 11

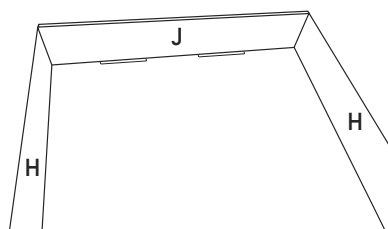


Figure 12

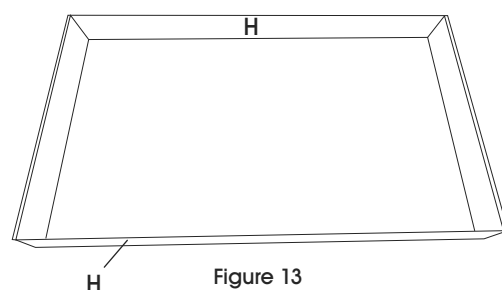


Figure 13

3. On the same side of the box lid, fold box top lid (J) over tabs (I), locking the top tab lids into slots (K) on the top panel. (See Figures 11-12)
4. Repeat steps 1-3 for the other side.
5. Lid assembled. (See Figure 13)

## BOX DIVIDER ASSEMBLY

### SHORT DIVIDER

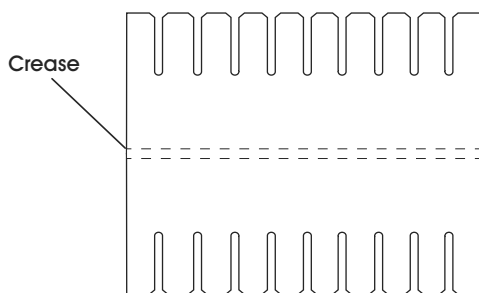


Figure 14

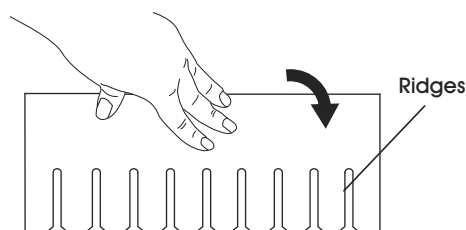


Figure 15

1. Fold short divider along the crease line. (See Figures 14-15)

## BOX DIVIDER ASSEMBLY CONTINUED

### LONG DIVIDER

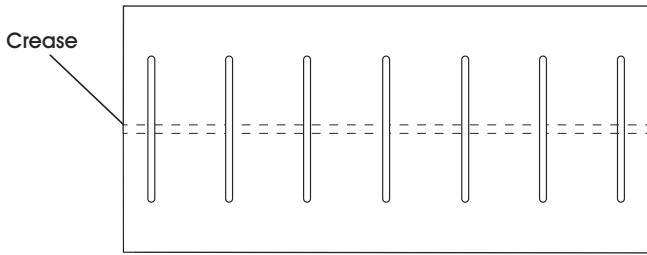


Figure 16

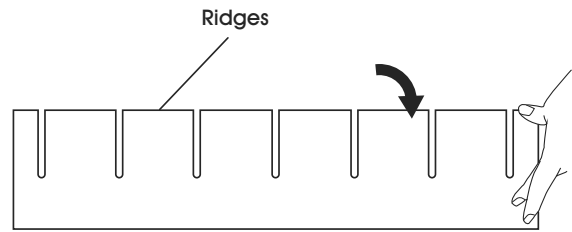


Figure 17

1. Fold long divider along the crease line. (See Figures 16-17)

### INSERTING DIVIDERS

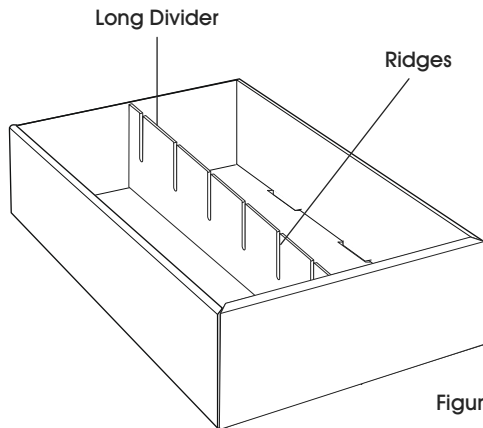


Figure 18

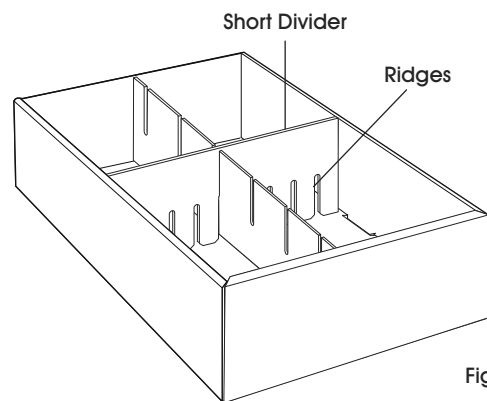
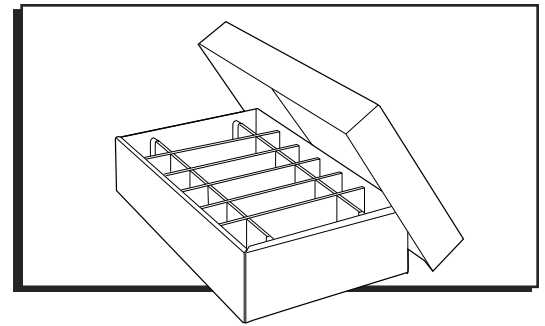


Figure 19

1. Insert long divider into the box as needed, ridges facing upward. (See Figure 18)
2. Insert short divider into the box as needed, ridges facing downward and align with the ridge from the long divider. (See Figure 19)

**ULINE S-18439**  
**CORSTAT™ CAJA**  
**CON DIVISORES –**  
**17 x 10 x 4"**

800-295-5510  
 uline.mx



**ENSAMBLE DE LA CAJA**

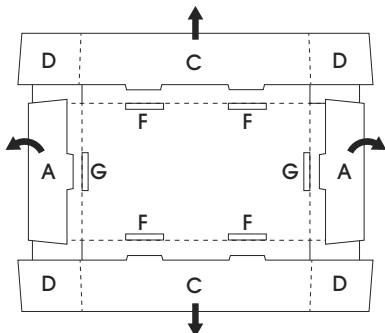


Diagrama 1

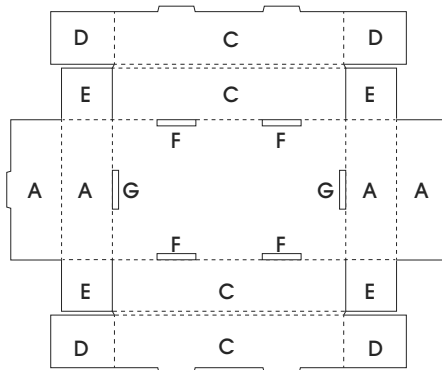


Diagrama 2

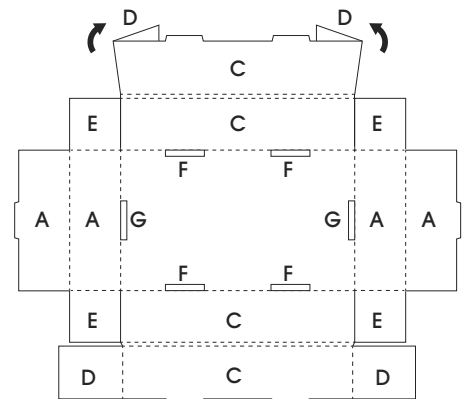


Diagrama 3

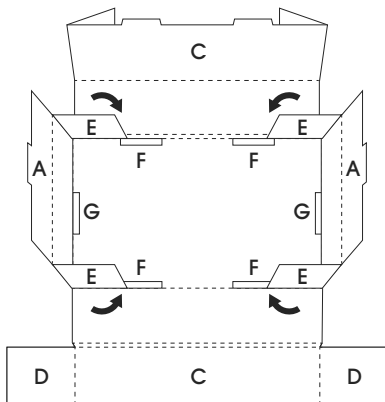


Diagrama 4

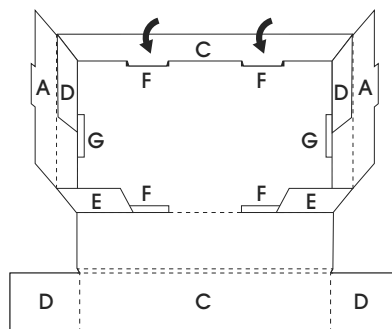


Diagrama 5

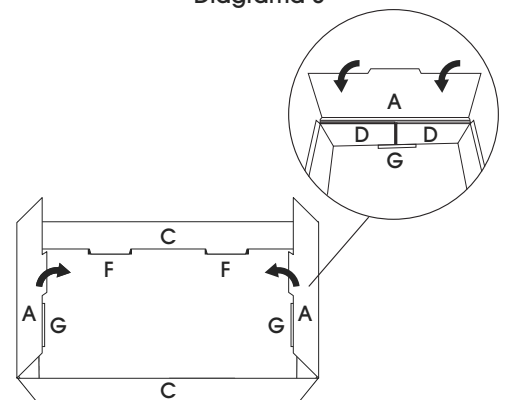


Diagrama 6

1. Coloque la caja sin ensamblar sobre una superficie plana con las solapas viendo hacia arriba. (Vea Diagrama 1)
2. Desdoble todas las solapas. (Vea Diagrama 2)
3. En un lado, doble las solapas laterales (D) hacia afuera. (Vea Diagrama 3)
4. En un lado corto de la caja, doble hacia adentro todas las solapas laterales (E) sobre las ranuras (F). (Vea Diagrama 4)
5. Doble el panel lateral (C) sobre las solapas laterales (E). Asegúrese de que las solapas laterales (D) estén dobladas hacia afuera y contra el panel lateral (A). (Vea Diagrama 5)
6. Fije las pestañas del panel lateral (C) dentro de las ranuras (F). (Vea Diagrama 6)
7. Repita los pasos 3-6 en el otro lado.

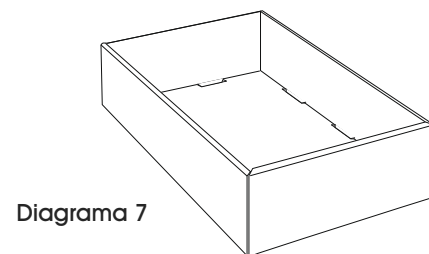


Diagrama 7

8. Doble la solapa lateral (A) sobre las solapas laterales (D), fijando la pestaña de la solapa lateral (A) dentro de las ranuras (G). (Vea Diagrama 6)
9. Repita el paso 8 en el otro lado.
10. La caja ya está ensamblada. (Vea Diagrama 7)

## ENSAMBLE DE LA TAPA DE LA CAJA

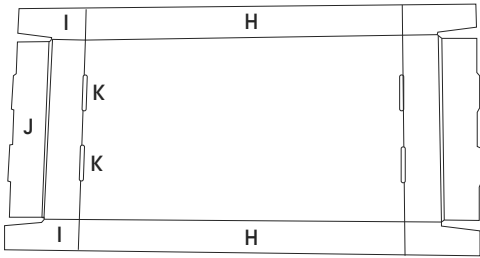


Diagrama 8

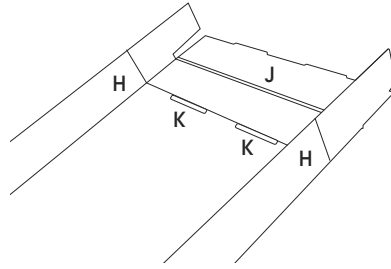


Diagrama 9

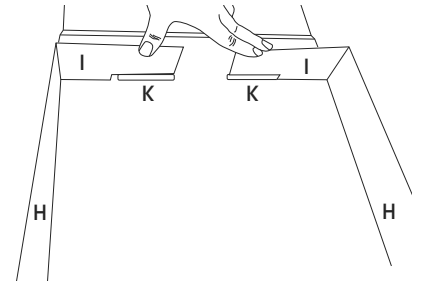


Diagrama 10

1. Doble los laterales de la tapa (H) a lo largo del pliegue. (Vea Diagramas 8-9)

2. En un lado de la tapa de la caja, doble los laterales de la tapa (I) sobre las ranuras (K). (Vea Diagrama 10)

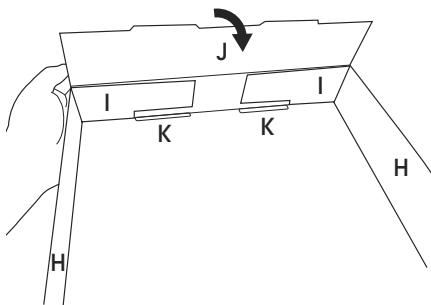


Diagrama 11

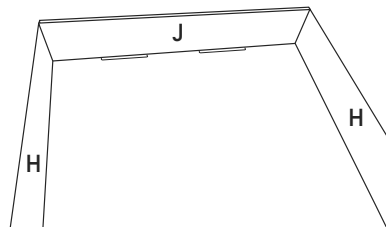


Diagrama 12

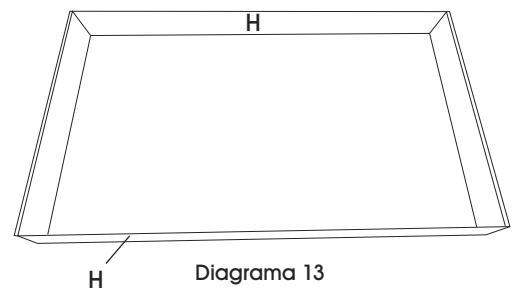


Diagrama 13

3. En el mismo lado de la tapa de caja, doble la tapa superior de la caja (J) sobre las pestañas (I), fijando las pestañas de las tapas superiores en las ranuras (K) en el panel superior. (Vea Diagramas 11-12)

4. Repita los pasos 1-3 en el otro lado.

5. La tapa ya está ensamblada. (Vea Diagrama 13)

## ENSAMBLE DE LOS SEPARADORES DE LA CAJA

### SEPARADOR CORTO

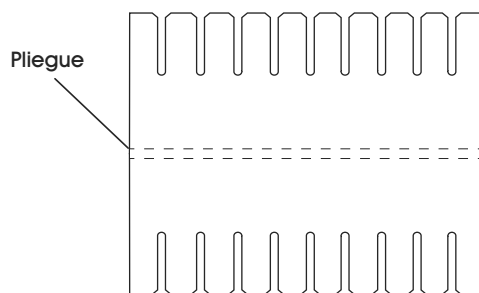


Diagrama 14

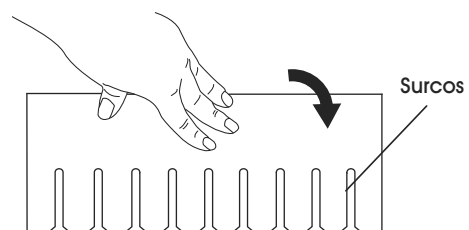


Diagrama 15

1. Doble el separador corto a la par de la línea de Doble el separador corto a la par de la línea de pliegue. (Vea Diagramas 14-15)

# CONTINUACIÓN DEL ENSAMBLE DE LOS SEPARADORES DE LA CAJA

## SEPARADOR LARGO

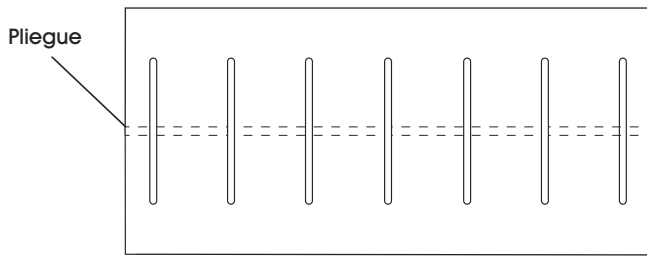


Diagrama 16

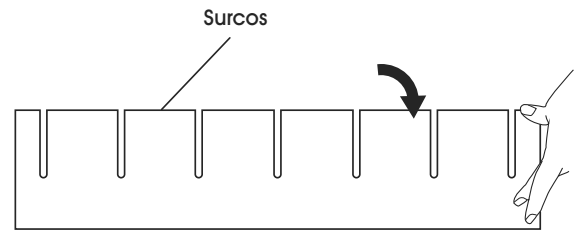


Diagrama 17

1. Doble el separador largo a la par de la línea de plegue. (Vea Diagramas 16-17)

## INSERTAR LOS SEPARADORES

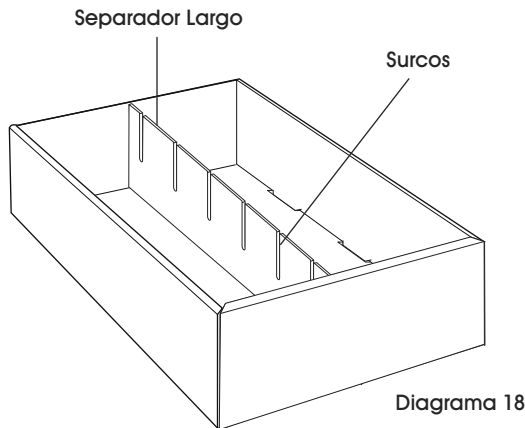


Diagrama 18

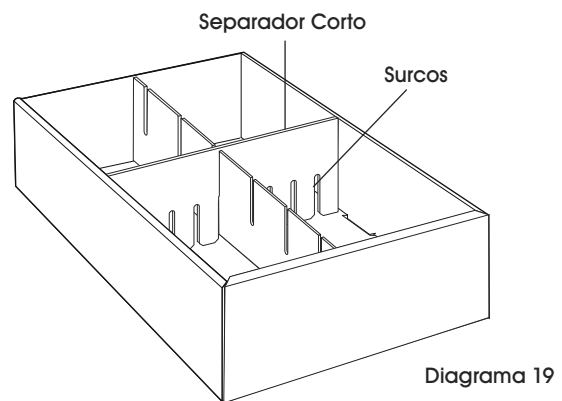


Diagrama 19

1. Inserte el separador largo dentro de la caja como se necesite, los surcos viendo hacia arriba. (Vea Diagrama 18).
2. Inserte el separador corto dentro de la caja como se necesite, los surcos mirando hacia abajo y alinee con el surco del separador largo. (Vea Diagrama 19).

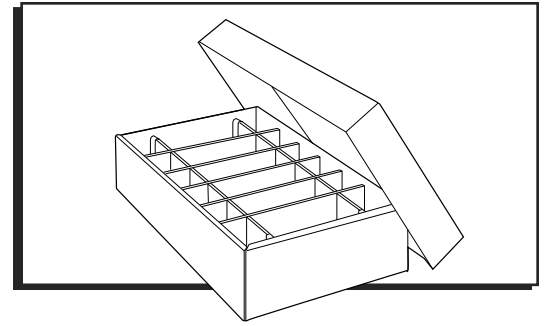
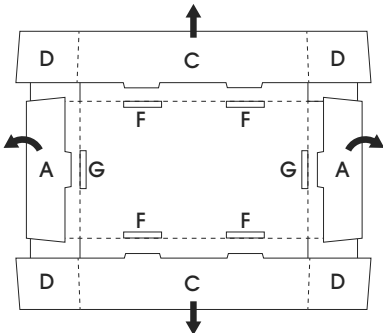
**MONTAGE DE LA BOÎTE**

Figure 1

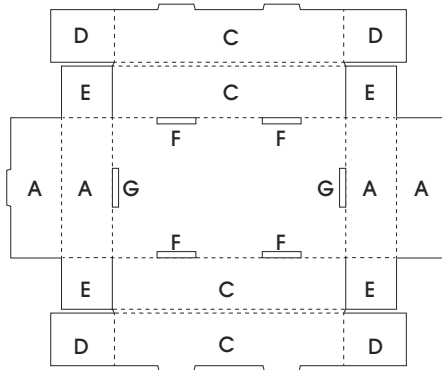


Figure 2

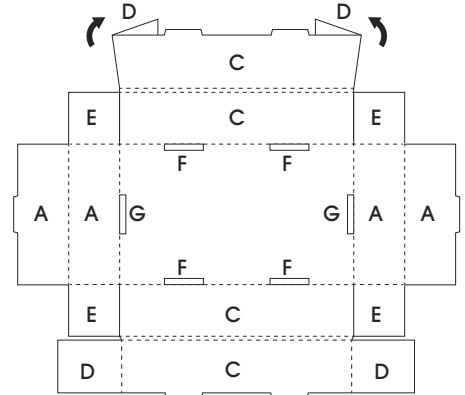


Figure 3

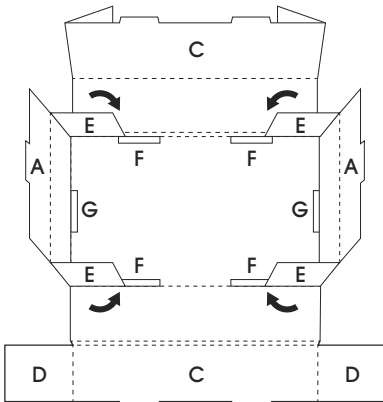


Figure 4

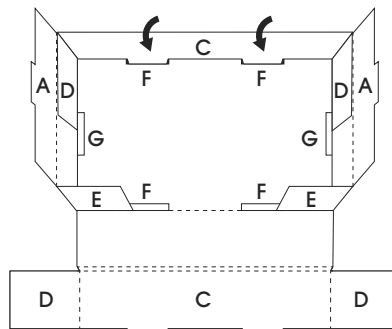


Figure 5

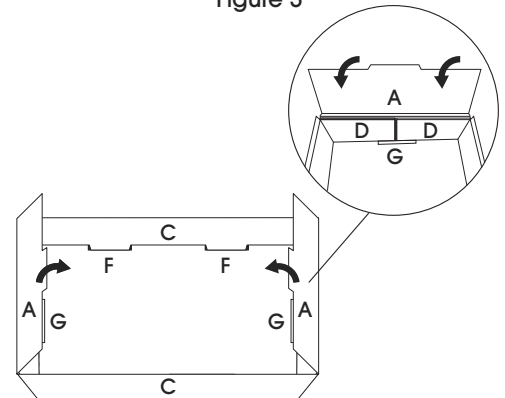
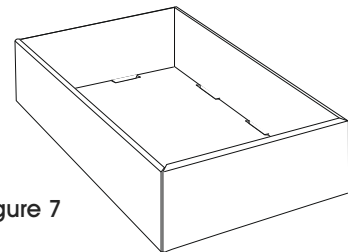


Figure 6

1. Placez la boîte non assemblée sur une surface plane avec les rabats orientés vers le haut. (Voir Figure 1)
2. Dépliez les rabats. (Voir Figure 2)
3. Pliez les rabats latéraux (D) de l'un des côtés vers l'extérieur. (Voir Figure 3)
4. Pliez les quatre rabats latéraux (E) sur les fentes (F) sur le côté le plus court de la boîte. (Voir Figure 4)
5. Pliez le panneau latéral (C) sur les fentes (E). Vérifiez que les rabats latéraux (D) sont pliés vers l'extérieur et qu'ils sont placés contre le panneau latéral (A). (Voir Figure 5)
6. Sécurisez les languettes du panneau latéral (C) dans les fentes (F). (Voir Figure 6)

Figure 7



7. Répétez les étapes 3 à 6 sur le côté opposé.
8. Pliez le rabat latéral (A) par-dessus les rabats latéraux (D) et sécurisez la languette du rabat latéral (A) dans les fentes (G). (Voir Figure 6)
9. Répétez l'étape 8 sur le côté opposé.
10. La boîte est assemblée. (Voir Figure 7)

## MONTAGE DU COUVERCLE DE BOÎTE

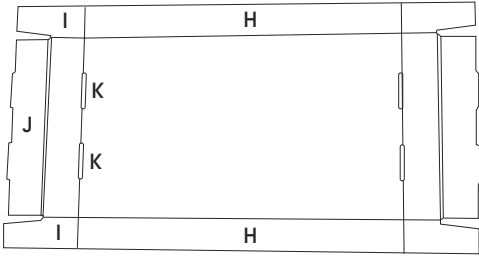


Figure 8

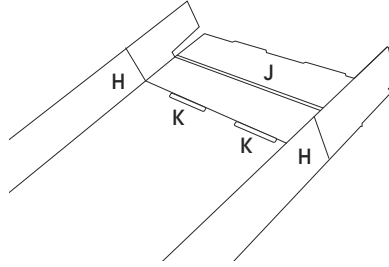


Figure 9

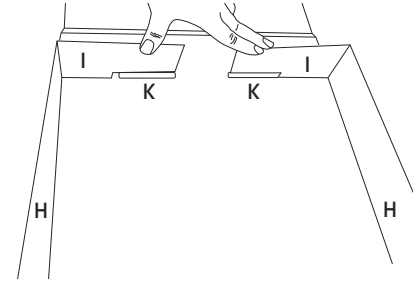


Figure 10

1. Pliez les côtés du couvercle (H) le long de la rainure. (Voir Figure 8 et 9)
2. Sur un des côtés du couvercle, pliez les côtés (I) sur les fentes (K). (Voir Figure 10)

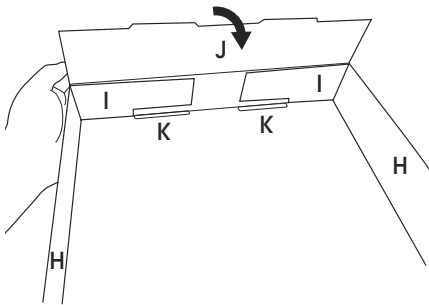


Figure 11

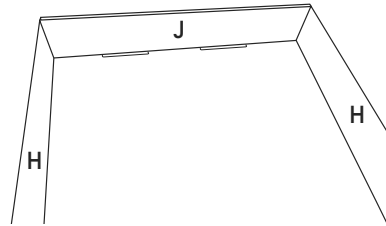


Figure 12

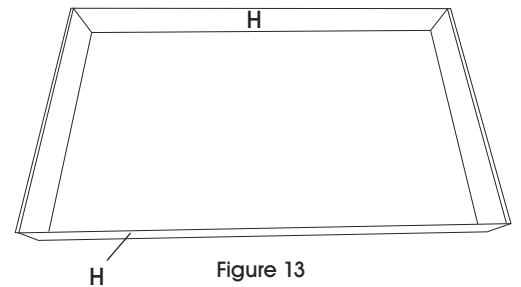


Figure 13

3. Sur le même côté, pliez le couvercle supérieur de la boîte (J) par-dessus les languettes (I) et insérez les languettes dans les fentes (K) du panneau supérieur. (Voir Figure 11 et 12)
4. Répétez les étapes 1 à 3 sur le côté opposé.
5. Le couvercle est assemblé. (Voir Figure 13)

## MONTAGE DES SÉPARATEURS DE BOÎTE

### SÉPARATEUR COURT

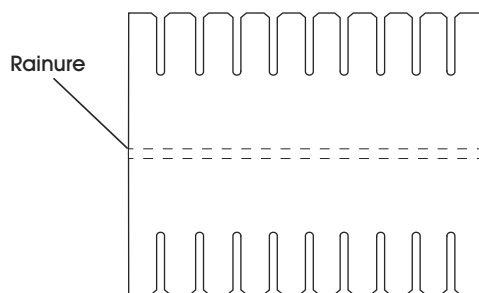


Figure 14

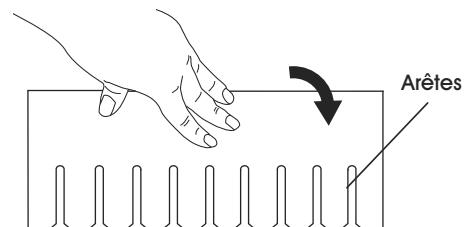


Figure 15

1. Pliez le séparateur court le long de la rainure. (Voir Figure 14 et 15)



# MONTAGE DES SÉPARATEURS DE BOÎTE SUITE

## SÉPARATEUR LONG

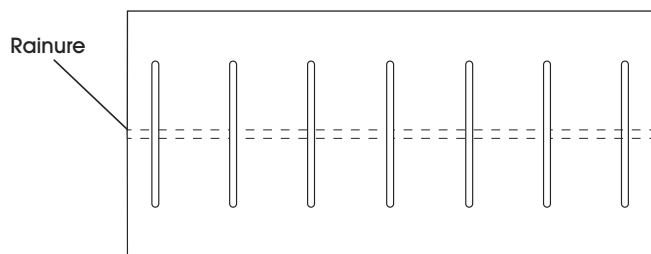


Figure 16

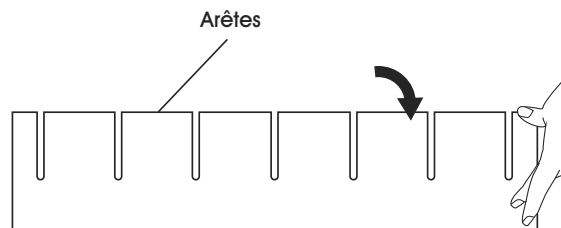


Figure 17

1. Pliez le séparateur long le long de la rainure. (Voir Figure 16 et 17)

## INSERTION DES SÉPARATEURS

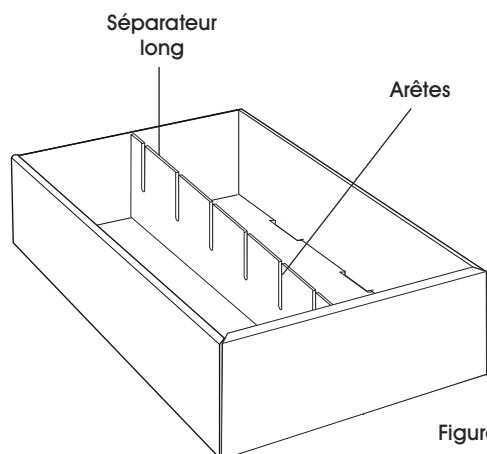


Figure 18

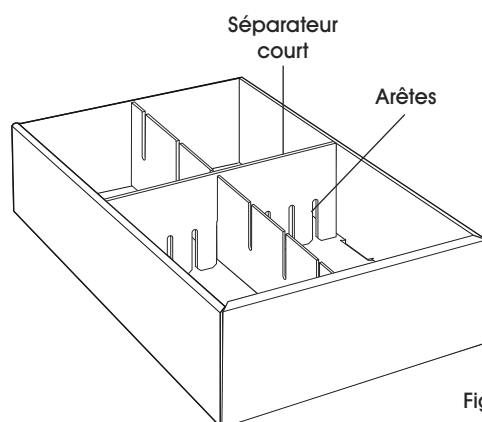


Figure 19

1. Insérez dans la boîte et à la position désirée le séparateur long, arêtes orientées vers le haut. (Voir Figure 18)
2. Insérez dans la boîte et à la position désirée le séparateur court, arêtes orientées vers le bas et alignées sur les arêtes du séparateur long. (Voir Figure 19)