

ULINE S-18281, S-18282
S-18283, S-19760
S-20419, S-21532
DELUXE BOX LINERS

1-800-295-5510
uline.com

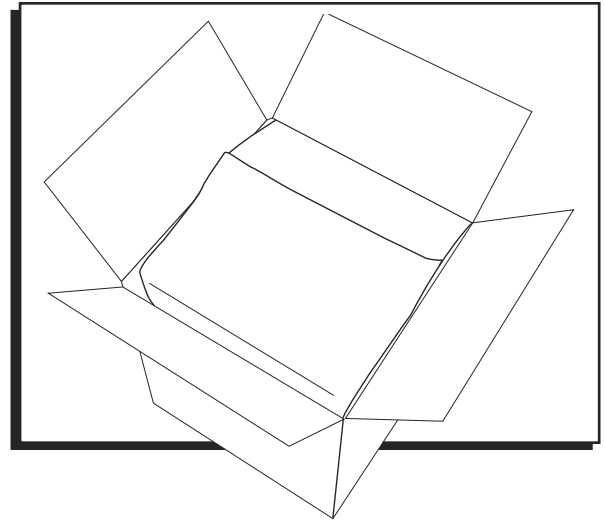

ASSEMBLY INSTRUCTIONS

 **NOTE:** For S-18282, S-18283, S-19760 and S-21532: Remove plastic and unroll the liner.

1. Place hands on the sides of the liner and push to form a flat bottom. Fold excess material under the bottom of the liner. (See Figure 1)

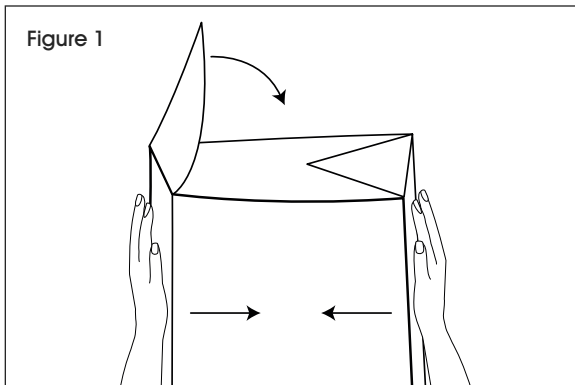

2. Insert folded liner into the box (not included).
3. Load contents and refrigerant.
4. Peel the backing paper off the adhesive strip. Pull liner on opposite ends along adhesive strip. (See Figure 2)

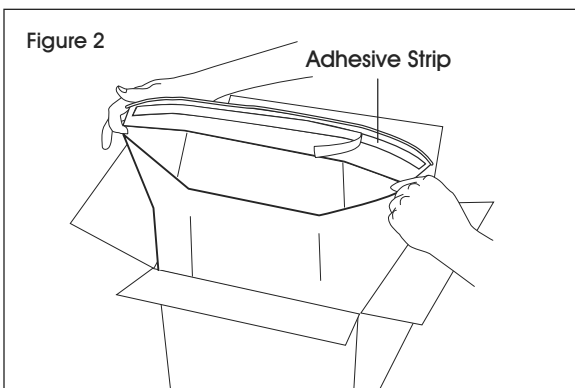

5. Push air out and close tape gradually from side to side. (See Figure 3)

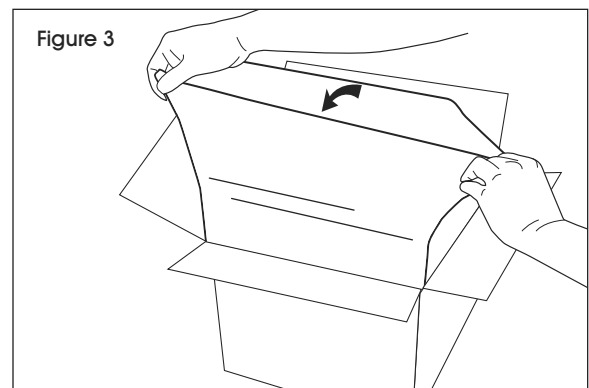

6. Tuck the edges of the liner between the side of the liner and the box. (See Figure 4)

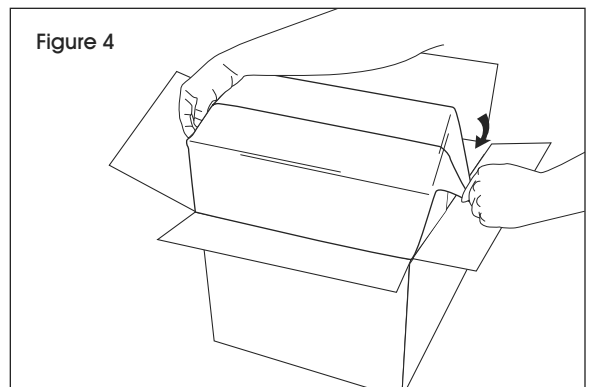

7. Tape the box shut.



S-18281, S-18282
 S-18283, S-19760
 S-20419, S-21532

FORROS PARA CAJAS DE ALTA CALIDAD

800-295-5510
 uline.mx

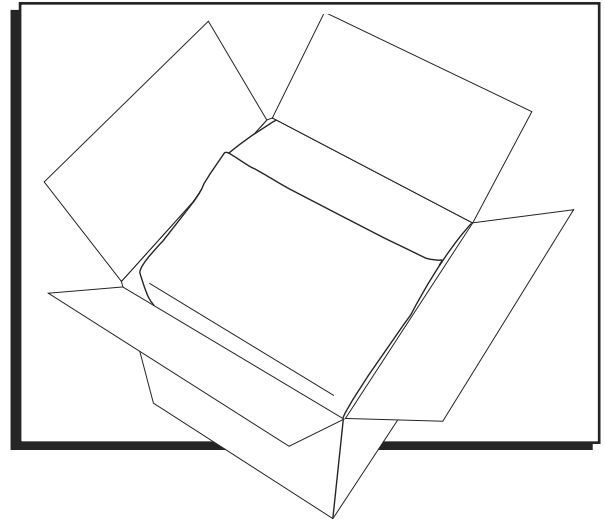

INSTRUCCIONES DE ENSAMBLE



NOTA: Para S-18282, S-18283, S-19760 y S-21532:
 Retire el plástico y desenrolle el forro.

1. Coloque las manos en los lados del forro y empuje para aplanar la base. Doble el material excedente de manera que quede bajo la base del forro. (Vea Diagrama 1)

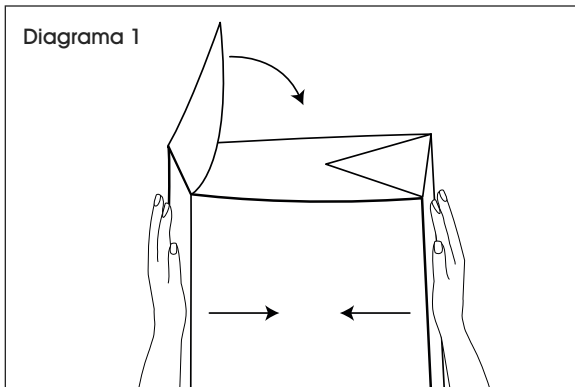

2. Inserte el forro plegado en la caja (no incluida).
3. Inserte el contenido y el refrigerante.
4. Despegue el reverso de papel de la tira adhesiva. Estire del forro en los extremos opuestos por la tira adhesiva. (Vea Diagrama 2)

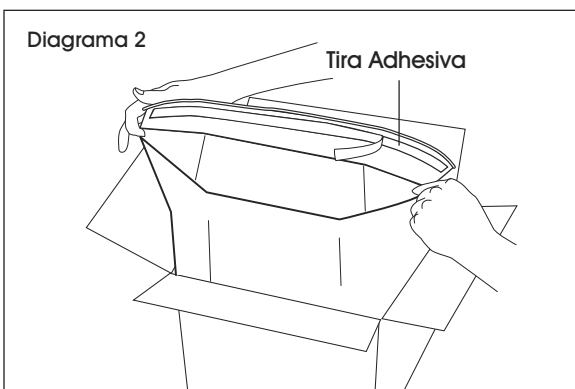

5. Expulse el aire y cierre la cinta gradualmente de un extremo al otro. (Vea Diagrama 3)

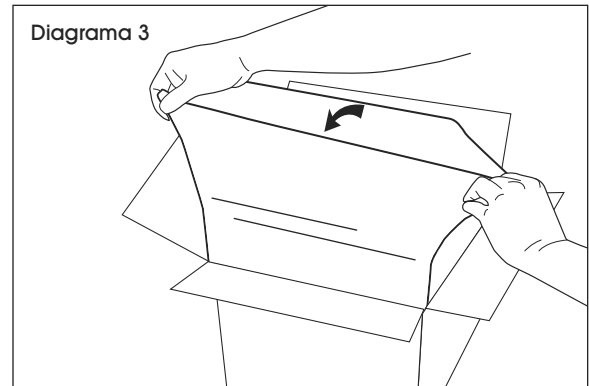

6. Meta los extremos del forro entre el lado del forro y la caja. (Vea Diagrama 4)

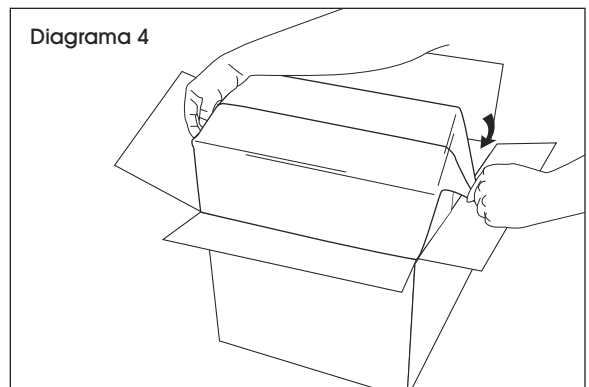

7. Cierre la caja con cinta adhesiva.

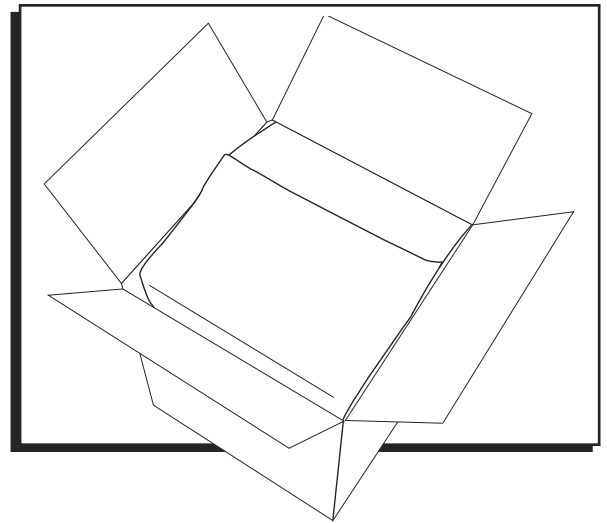
**DOUBLURE DE LUXE
POUR BOÎTES****INSTRUCTIONS D'ASSEMBLAGE**

REMARQUE : Pour S-18282, S-18283, S-19760 et S-21532 : Retirez le plastique et déroulez la doublure.

1. Placez les mains sur les côtés de la doublure et poussez pour former un fond plat. Pliez le matériel en excès sous le fond de la doublure (Voir Figure 1)

Figure 1

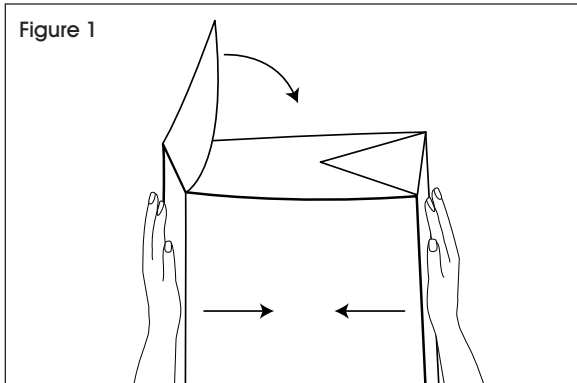

2. Insérez la doublure pliée dans la boîte (non comprise).
3. Placez le contenu dans la boîte.
4. Décollez la pellicule de la bande adhésive. Tirez sur la doublure aux extrémités de la bande adhésive. (Voir Figure 2)

Figure 2

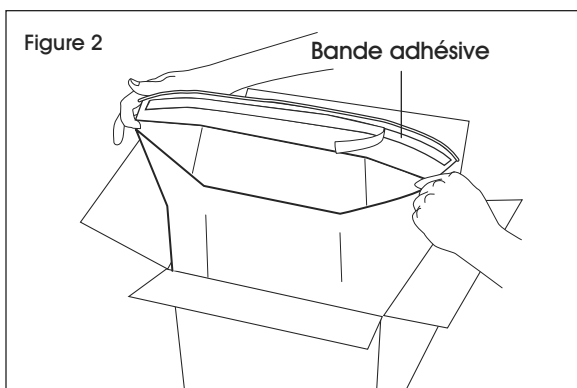

5. Expulsez l'air et fermez la bande graduellement d'un côté à l'autre (Voir Figure 3)

Figure 3

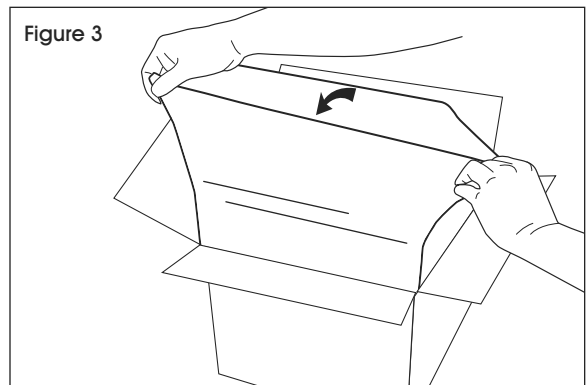

6. Rentrez les bords la doublure entre le côté de la doublure et la boîte. (Voir Figure 4)

Figure 4

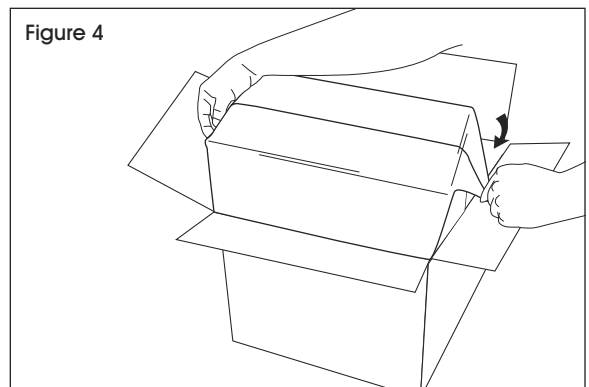

7. Scellez la boîte avec du ruban adhésif.