

ULINE S-17334, S-17335
S-17336, S-17337

ONE-PIECE CORRUGATED SHOE BOXES

1-800-295-5510
uline.com

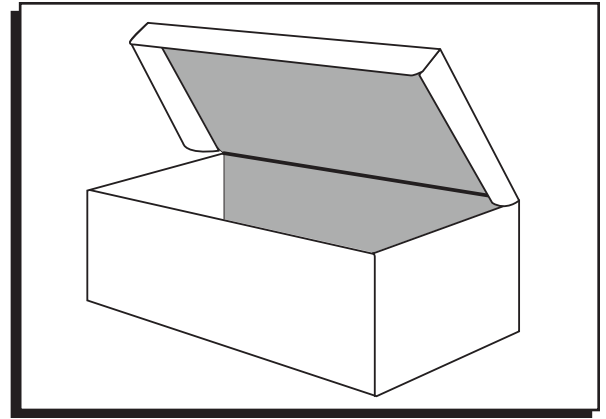

ASSEMBLY

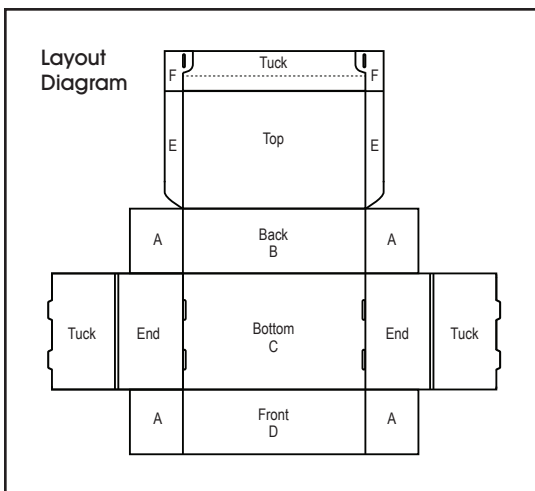

Figure 1

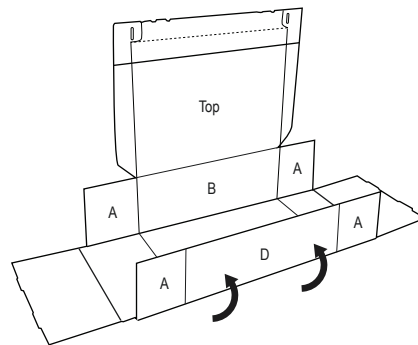

Figure 2

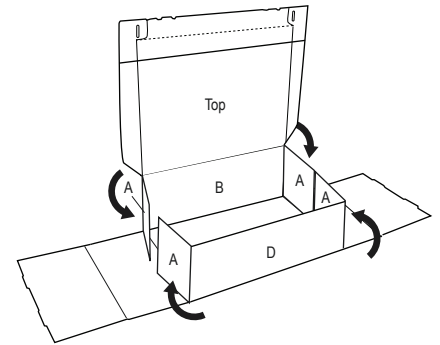

Figure 3

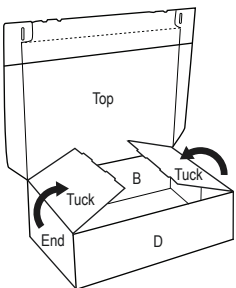

Figure 4

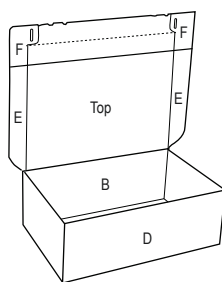

Figure 5

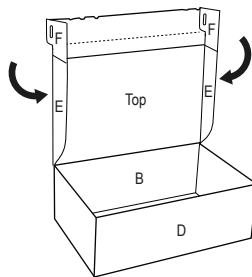

Figure 6

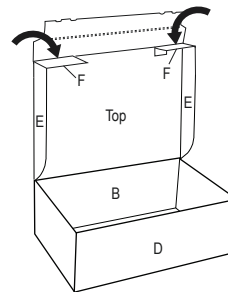
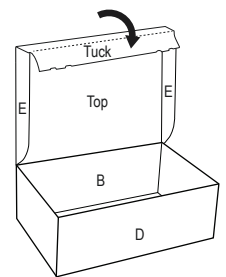

Figure 7



1. Lay board with prominent creases facing up.
2. Fold back (B) and front (D) panels straight up so they are perpendicular to bottom (C). (See Figure 1)
3. Fold in flaps (A). (See Figure 2)
4. To form sides of box, fold ends up and tuck panels over flaps (A) until tabs lock into slots in bottom (C). (See Figures 3 and 4)
5. Fold in left and right flaps (E) at sides of top. (See Figure 5)
6. Fold down slotted flaps (F) at right angle as shown. (See Figure 6)
7. To form lid, fold front edge of lid at perforations and tuck over until tabs lock into slots in top. (See Figure 7)

ULINE S-17334, S-17335
S-17336, S-17337

CAJAS DE CARTÓN DE UNA PIEZA PARA ZAPATOS

800-295-5510
uline.mx

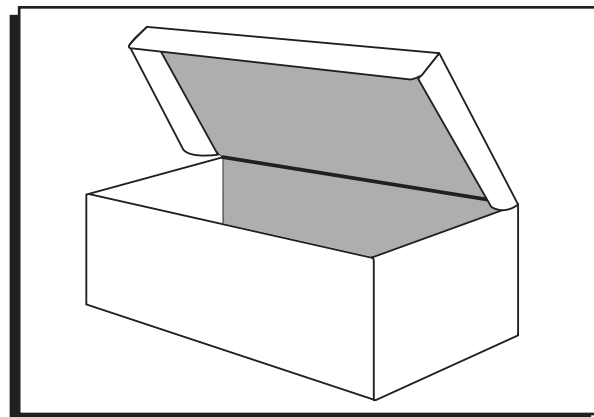

ENSAMBLE



Diagrama 1



Diagrama 2

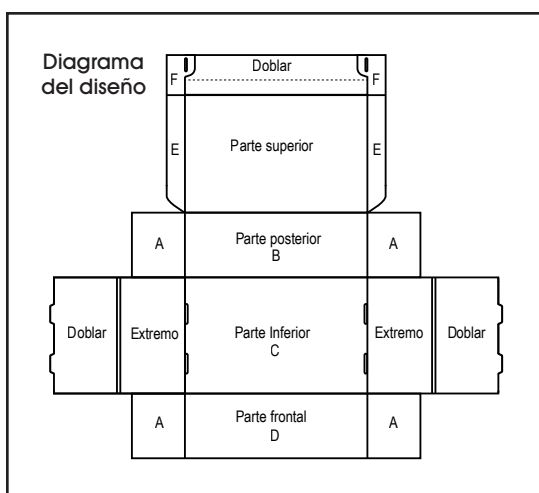

Diagrama 3

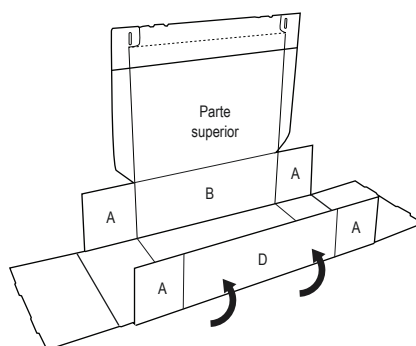

Diagrama 4

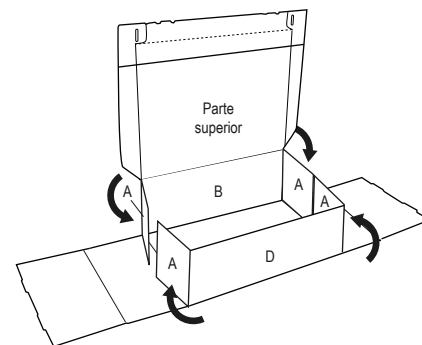

Diagrama 5

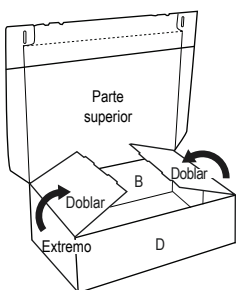

Diagrama 6

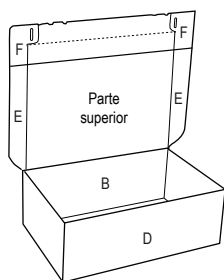

Diagrama 7

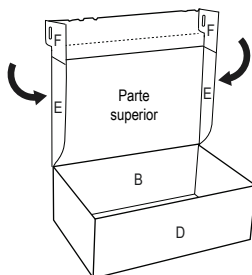

1. Coloque la lámina con los dobleces prominentes apuntando hacia arriba.
2. Doble los paneles trasero (B) y delantero (D) rectos para que queden perpendiculares a la parte inferior (B). (Vea Diagrama 1)
3. Doble las solapas hacia adentro (A). (Vea Diagrama 2)
4. Para dar forma a los lados de la caja, doble los extremos hacia arriba e inserte los paneles sobre las solapas (A) hasta que las pestañas entren en las ranuras de la parte inferior (C). (Vea Diagramas 3 y 4)
5. En los laterales de la parte superior, doble hacia dentro las solapas izquierda y derecha (E). (Vea Diagrama 5)
6. Doble las solapas ranuradas (F) hacia abajo en ángulo recto, como se muestra. (Vea Diagrama 6)
7. Para dar forma a la tapa, doble el borde delantero de la tapa por las perforaciones e insértelas hasta que las pestañas entren en las ranuras de la parte superior. (Vea Diagrama 7)

ULINE S-17334, S-17335
S-17336, S-17337

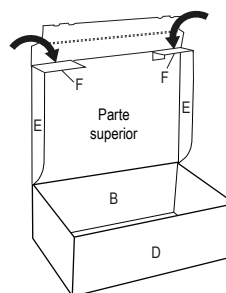
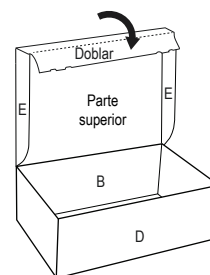
BOÎTES À CHAUSSURES EN CARTON ONDULÉ D'UNE PIÈCE

1-800-295-5510
uline.ca

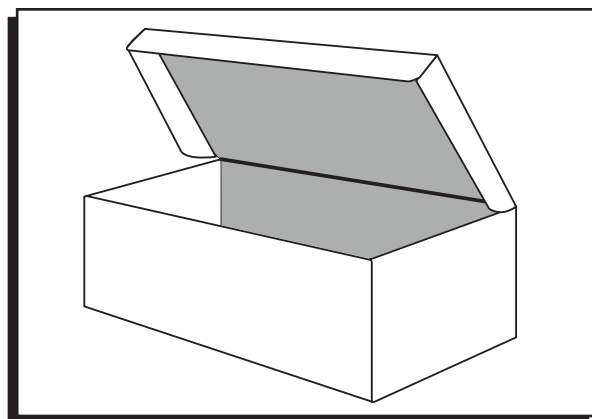

ASSEMBLAGE

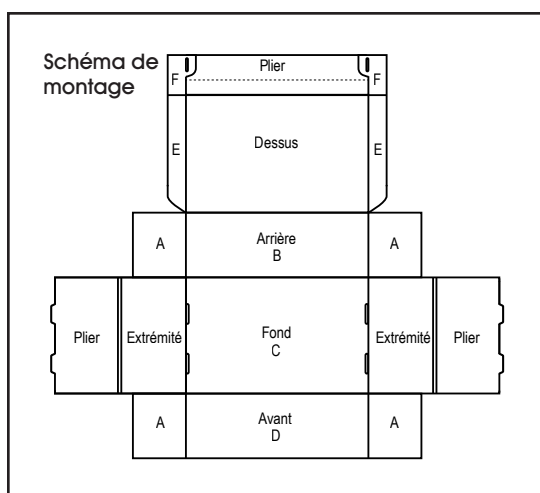

Figure 1

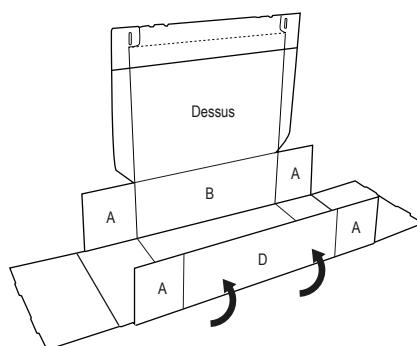

Figure 2

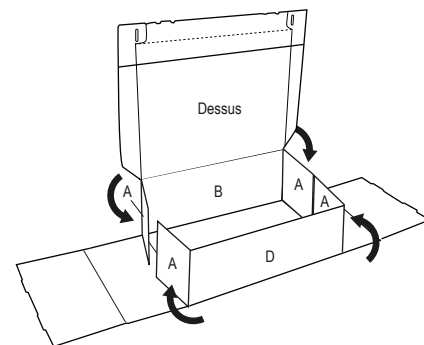

Figure 3

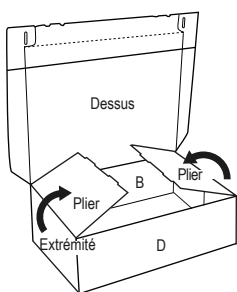

Figure 4

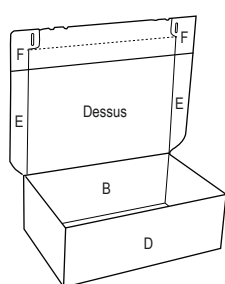

Figure 5

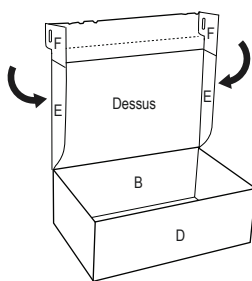

Figure 6

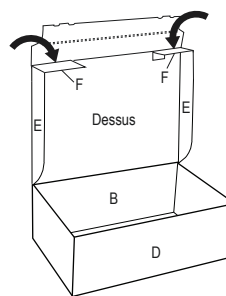
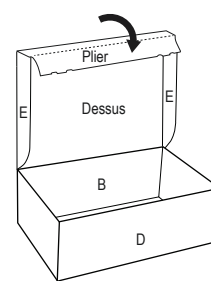

Figure 7



1. Posez la boîte à plat avec les pliures bien saillantes orientées vers le haut.
2. Pliez les panneaux arrière (B) et avant (D) bien vers le haut pour qu'ils soient perpendiculaires au fond (C). (Voir Figure 1)
3. Pliez les rabats (A). (Voir Figure 2)
4. Pour former les côtés de la boîte, pliez les extrémités vers le haut, puis repliez les panneaux par-dessus les rabats (A) jusqu'à ce que les languettes s'insèrent dans les fentes situées sur le fond (C). (Voir Figures 3 et 4)
5. Pliez vers l'intérieur les rabats latéraux gauche et droit (E) du dessus de la boîte. (Voir Figure 5)
6. Repliez les rabats à fente (F) pour former un angle droit, comme illustré. (Voir Figure 6)
7. Pour former le couvercle, pliez le rebord avant du couvercle aux perforations, puis continuez à le plier jusqu'à ce que les languettes s'insèrent dans les fentes situées sur le dessus de la boîte. (Voir Figure 7)