

ULINE S-16674 RETENTION BOX KIT

1-800-295-5510
uline.com

ASSEMBLY INSTRUCTIONS

1. **Pre-Fold** tension flaps to release film. Place product under film.

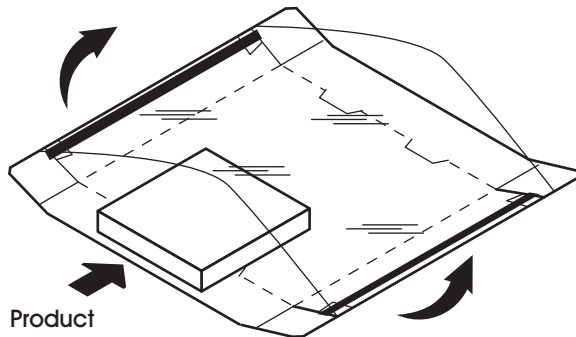

3. **Fold both tension flaps with equal force down and under base.**

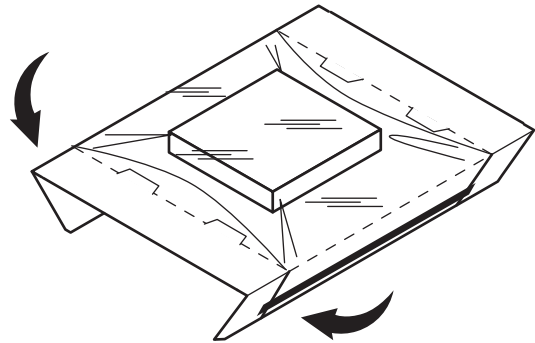

2. **Fold both outer panels upright.** Make sure pop-down tabs lock folded tension flaps into place.

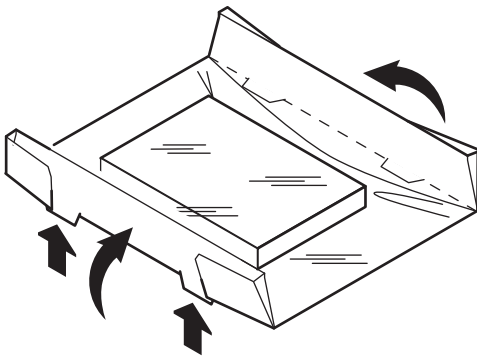

4. **Hold both outer panels while inserting into carton.**

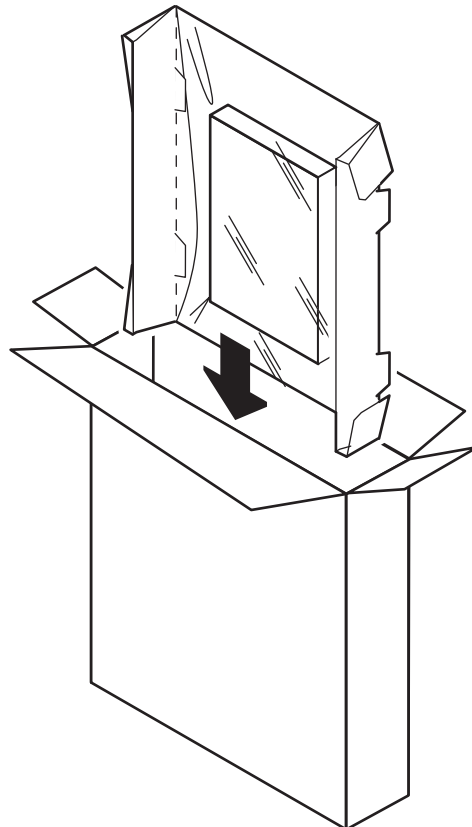

INSTRUCCIONES DE ENSAMBLE

1. Doble previamente las solapas de tensión para liberar la película. Coloque el producto debajo de la película.

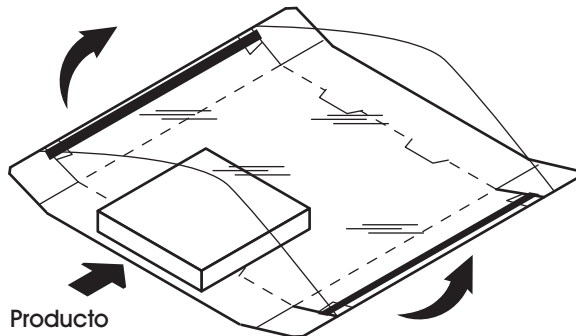

3. Doble ambas solapas con la misma fuerza hacia abajo y por debajo de la base.

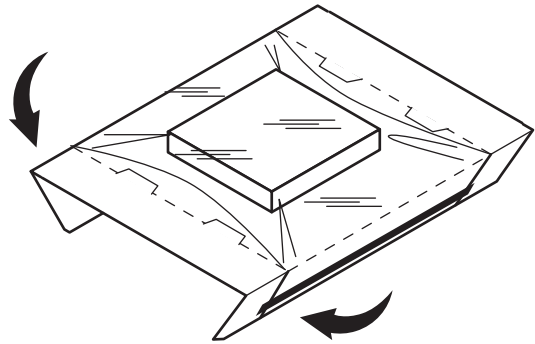

2. Doble ambos paneles exteriores para colocarlos en posición vertical. Asegúrese de que las pestañas sobresalientes traben las solapas de tensión dobladas en su lugar.

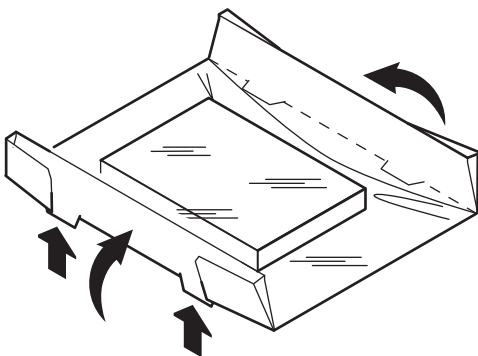

4. Sostenga ambos paneles exteriores mientras los inserta en la caja.

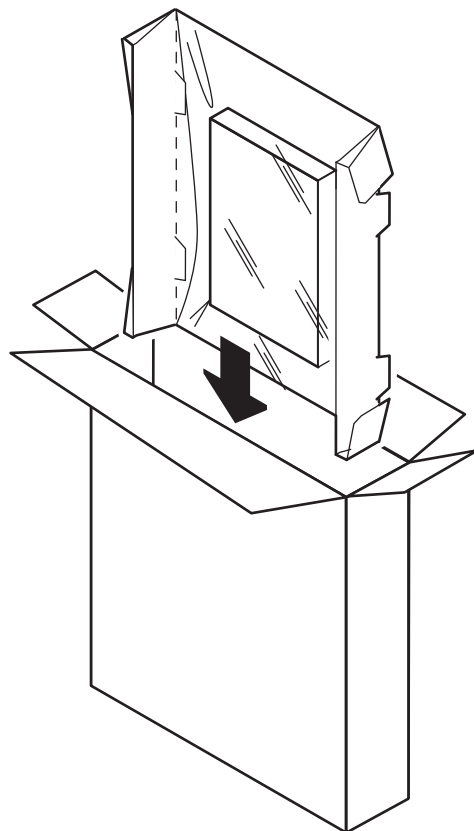

INSTRUCTIONS D'ASSEMBLAGE

1. Pliez les rabats de tension pour libérer la pellicule.
Placez l'article sous la pellicule.

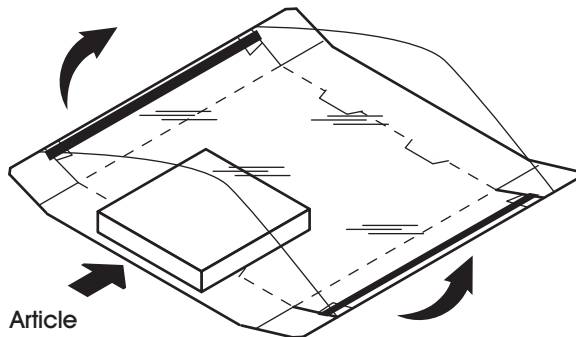

3. En exerçant une force égale, pliez les deux rabats de tension vers le bas, puis en dessous de la base.

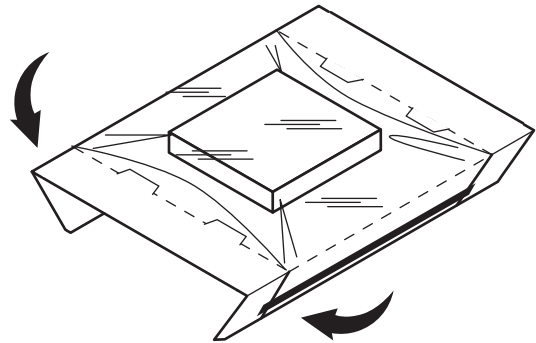

2. Pliez les deux panneaux extérieurs en position verticale. Assurez-vous que les languettes maintiennent les rabats de tension pliés en place.

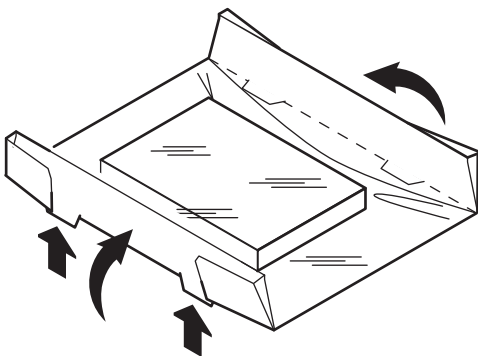

4. Tenez les deux panneaux extérieurs lorsque vous insérez dans la boîte.

