

ULINE S-16671 RETENTION BOX

1-800-295-5510
uline.com

ASSEMBLY INSTRUCTIONS

1. Lift tension flaps (A) and slide product under film.

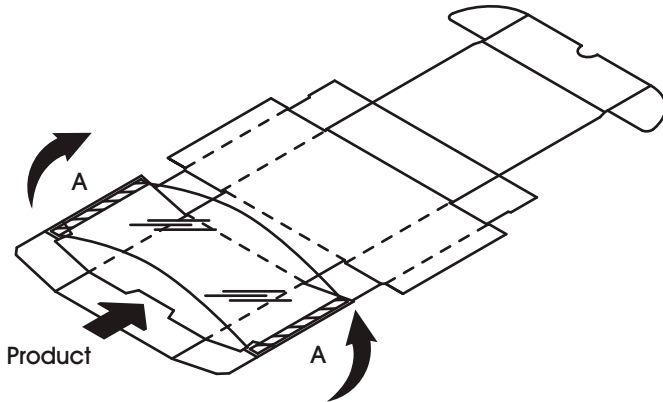

2. Fold both flaps (A) with equal force down and under panel (C).

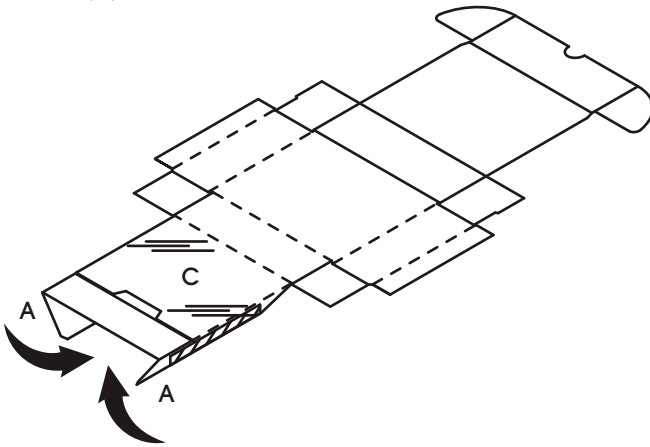

3. Lock the tab in place by folding panel (B). Roll panel (C) over panel (D).

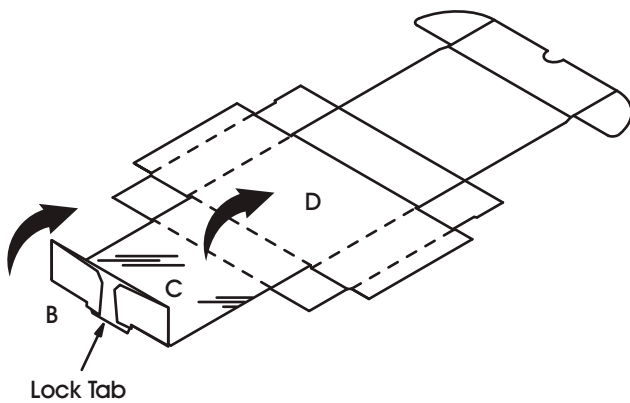

4. Fold smaller flaps toward the middle of the box.

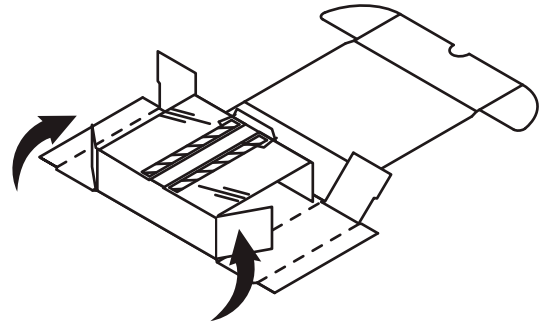

5. Fold side panels (E) and rails (F) over the top. Fold remaining flaps toward the middle.

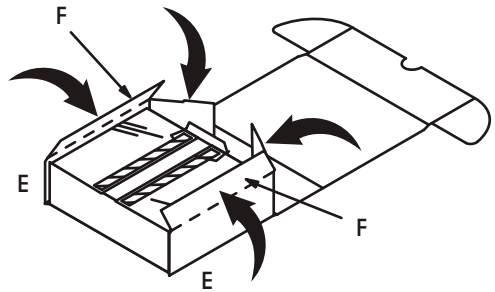

6. Roll panel (G) over the top and tuck flaps into side slots.

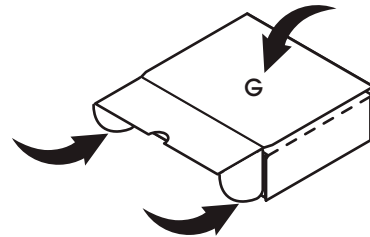

**CAJA DE
RETENCIÓN****INSTRUCCIONES DE ENSAMBLE**

1. Levante las solapas de tensión (A) y deslice el producto por debajo de la película.

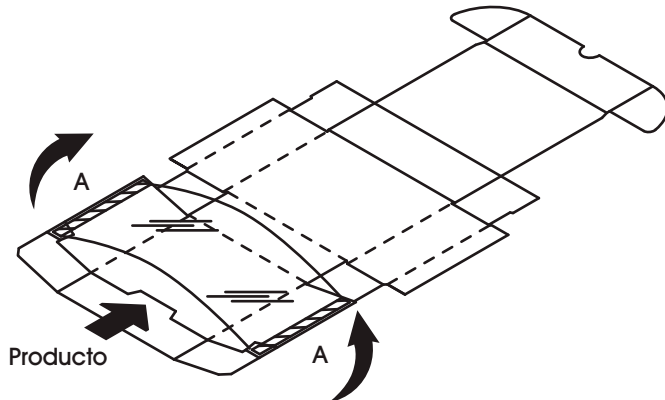

2. Doble ambas solapas (A) con la misma fuerza hacia abajo y por debajo del panel (C).

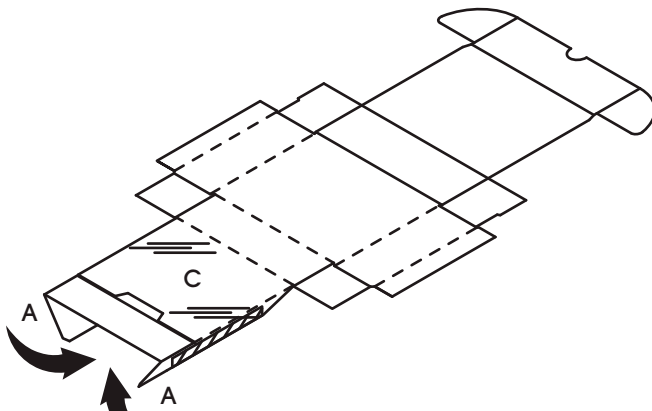

3. Asegure la pestaña en su lugar doblando el panel (B). Enrolle el panel (C) por encima del panel (D).

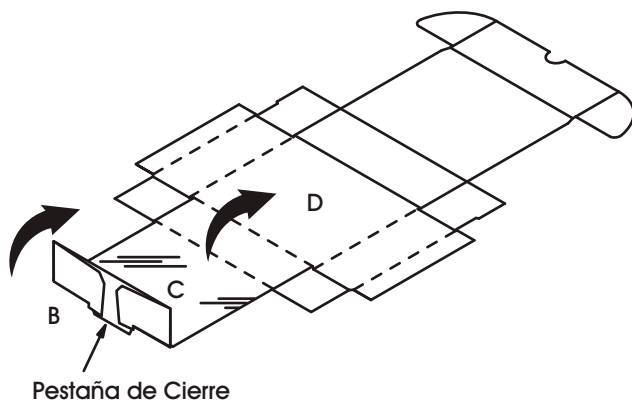

4. Doble las solapas más pequeñas hacia el centro de la caja.

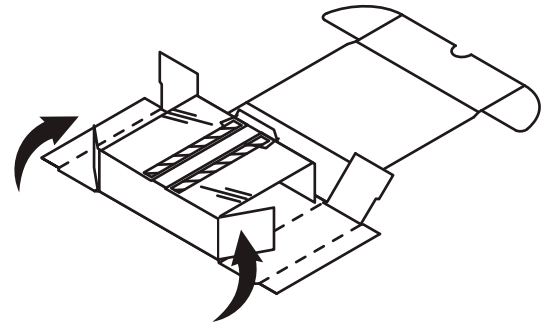

5. Doble los paneles laterales (E) y los rieles (F) por encima de la parte superior. Doble el resto de las solapas hacia el centro.

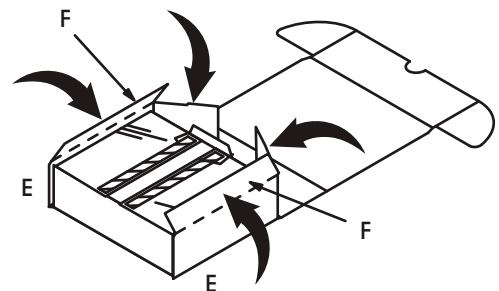

6. Enrolle el panel (G) por encima de la parte superior y meta las solapas por dentro de las ranuras laterales.

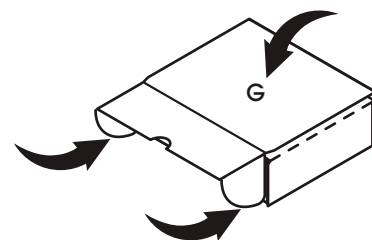

**BOÎTE DE
RÉTENTION****INSTRUCTIONS D'ASSEMBLAGE**

1. Soulevez les rabats de tension (A) et glissez l'article sous la pellicule.

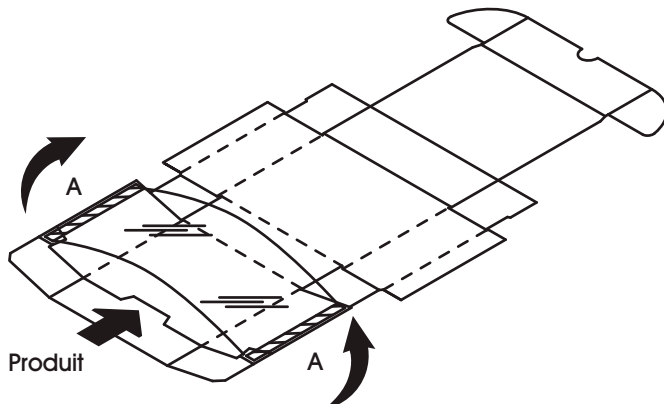

2. En exerçant une force égale, pliez les deux rabats (A) vers le bas, puis en dessous du panneau (C).

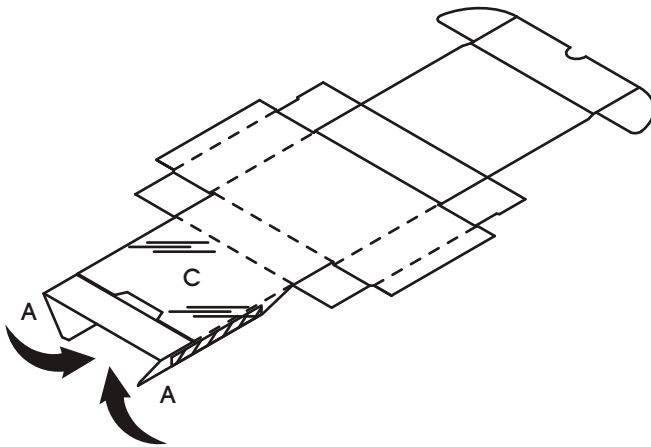

3. Bloquez la languette en position en pliant le panneau (B). Pliez le panneau (C) sur le panneau (D).

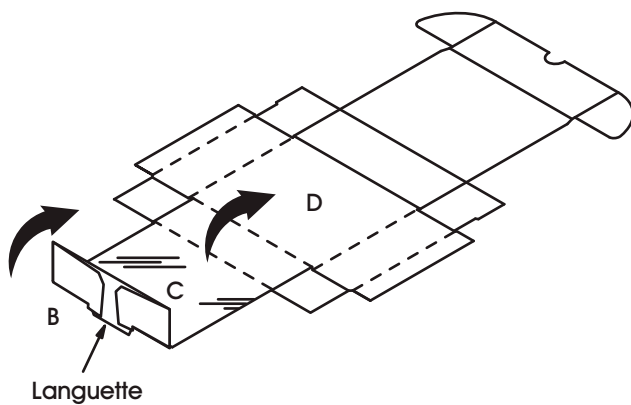

4. Pliez les petits rabats vers le milieu de la boîte.

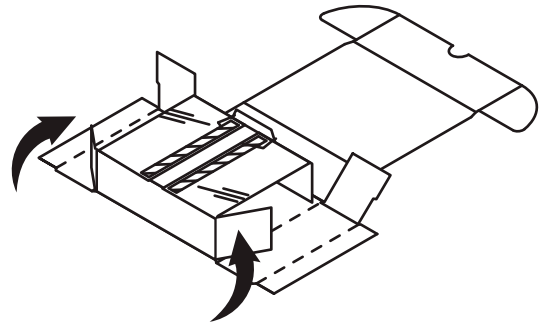

5. Pliez les panneaux latéraux (E) et les longerons (F) vers le haut. Pliez les autres petits rabats vers le milieu.

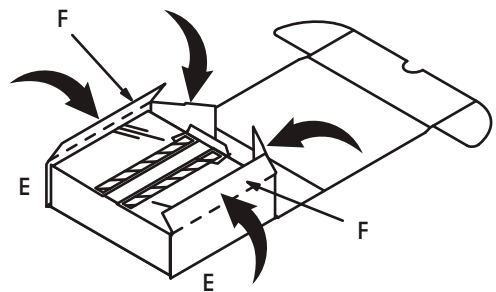

6. Repliez le panneau (G), puis rentrez les rabats dans les fentes latérales.

