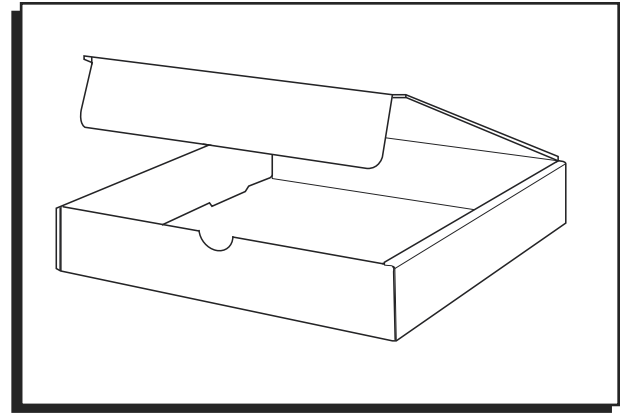


ULINE

LITERATURE MAILER

1-800-295-5510
uline.com



ASSEMBLY

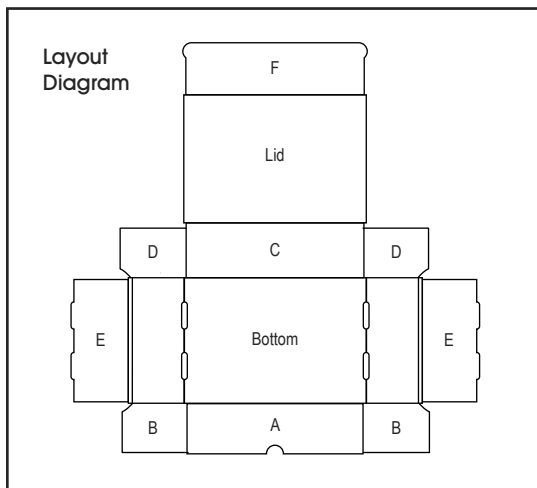


Figure 1

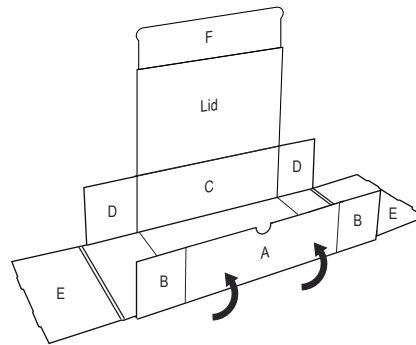


Figure 2

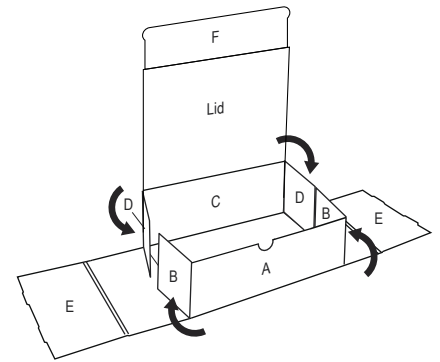


Figure 3

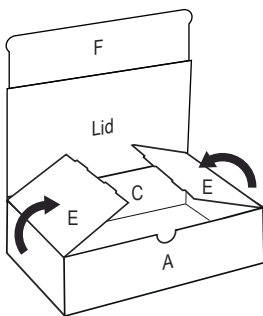


Figure 4

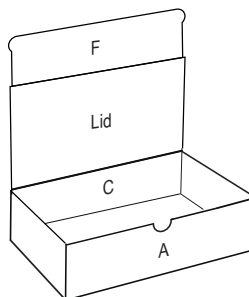
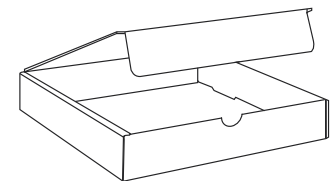


Figure 5



1. Fold panels A and C straight up so they are perpendicular to the bottom. (See Figure 1)
2. Fold in flaps B and D. (See Figure 2)
3. To form sides of box, fold ends E up and over flaps B and D, tucking into slots at the bottom. (See Figures 3 and 4)
4. Fold down lid and tuck panel F into mailer to close. (See Figure 5)

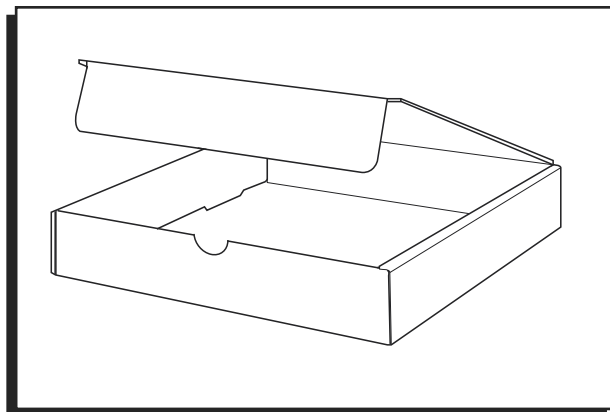
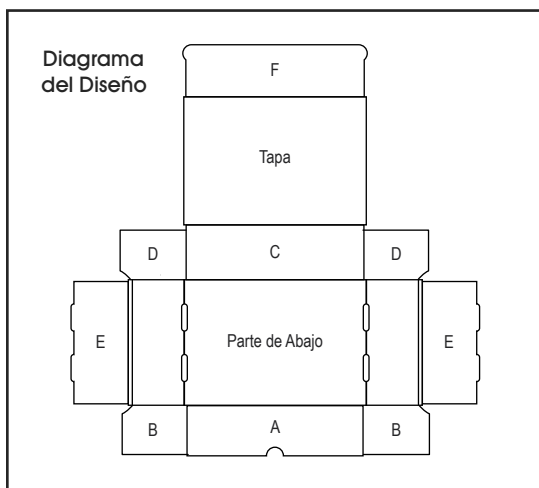
**ENSAMBLE**

Diagrama 1

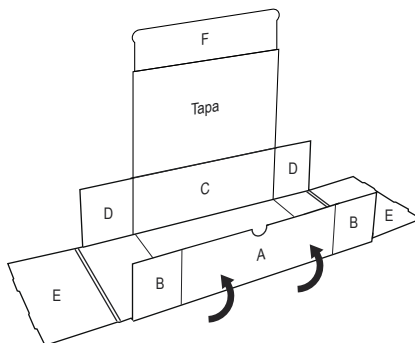


Diagrama 2

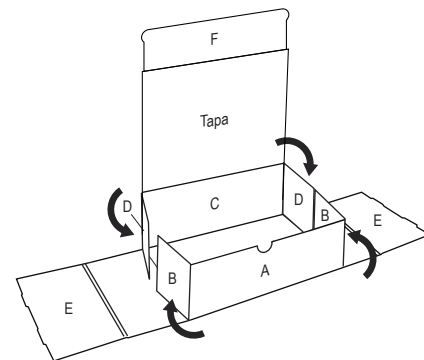


Diagrama 3

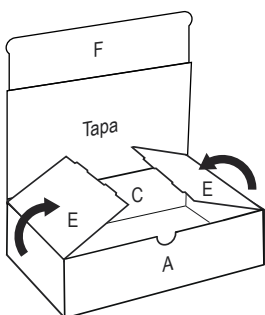


Diagrama 4

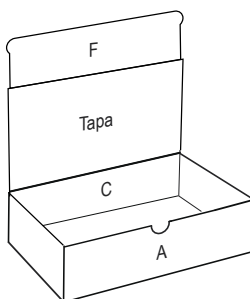
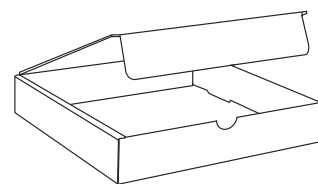


Diagrama 5



1. Doble los paneles A y C hacia arriba, de manera que queden perpendiculares a la parte de abajo. (Vea Diagrama 1)
2. Doble hacia adentro las solapas B y D. (Vea Diagrama 2)
3. Para formar los laterales de la caja, doble los extremos E hacia arriba y sobre las solapas B y D metiendo las pestañas en el fondo. (Vea Diagrama 3 y 4)
4. Doble la tapa hacia abajo y meta el panel F en la caja para cerrar. (Vea Diagrama 5)

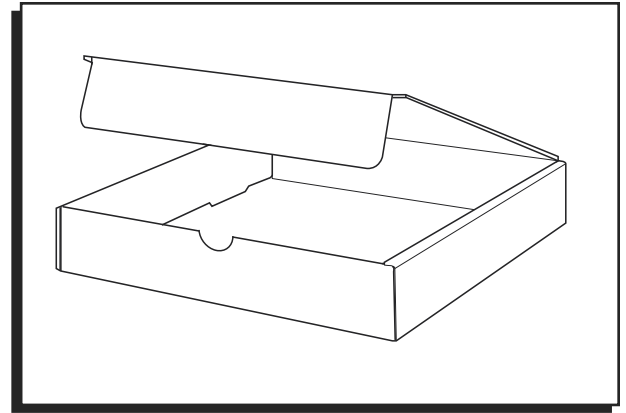
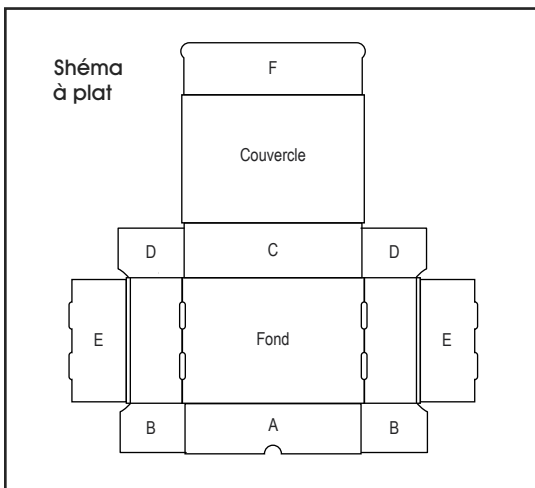
**ASSEMBLAGE**

Figure 1

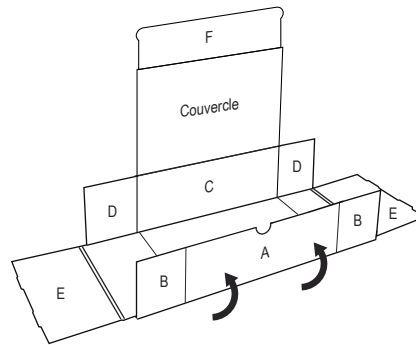


Figure 2

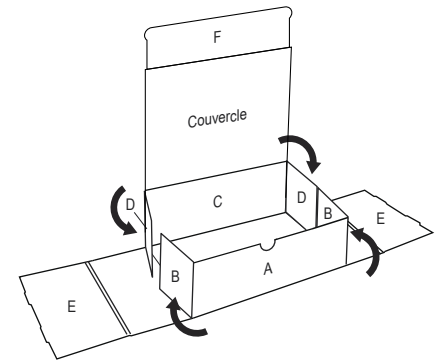


Figure 3

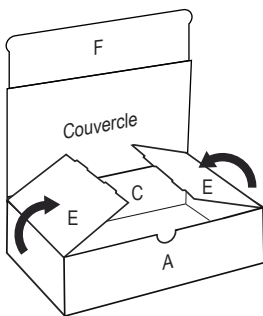


Figure 4

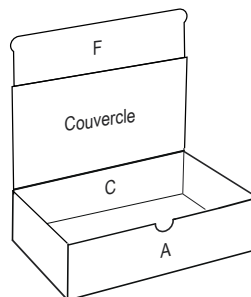
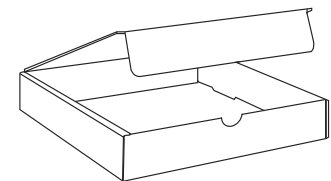


Figure 5



1. Pliez les panneaux A et C vers le haut afin qu'ils soient perpendiculaires avec le fond de la boîte. (Voir Figure 1)
2. Pliez les rabats B et D vers l'intérieur. (Voir Figure 2)
3. Pour former les côtés de la boîte, pliez les rabats E vers le haut et par dessus les rabats B et D. Insérez-les ensuite dans les fentes sur le fond. (Voir Figures 3 et 4)
4. Pliez le couvercle de la boîte et insérez la languette F à l'intérieur de la boîte pour la fermer. (Voir Figure 5)