

ULINE S-15024
DVD/CD STORAGE BOX

1-800-295-5510
uline.com

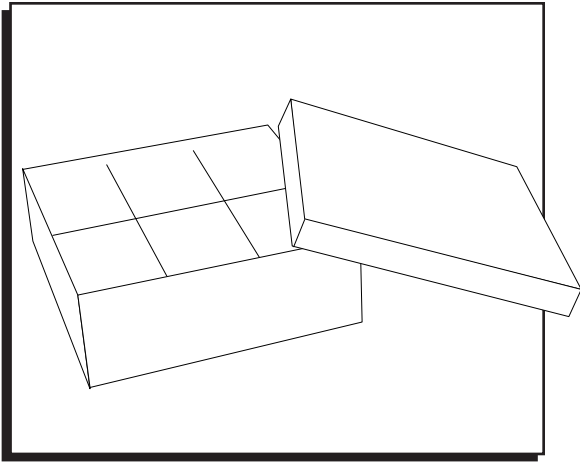

LID ASSEMBLY

Figure 1

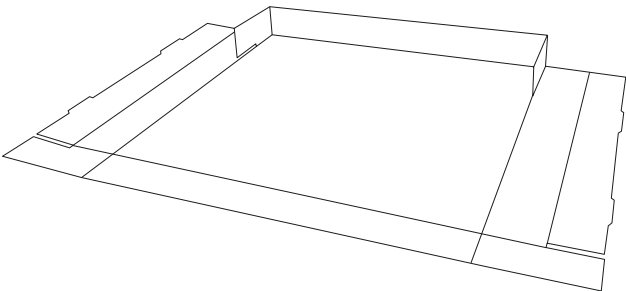

Figure 2

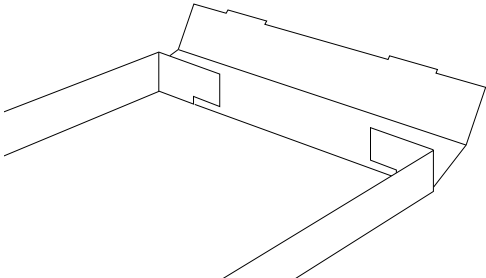
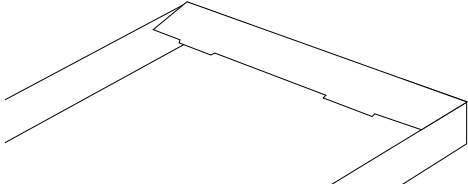

Figure 3



DIVIDERS ASSEMBLY

Figure 1

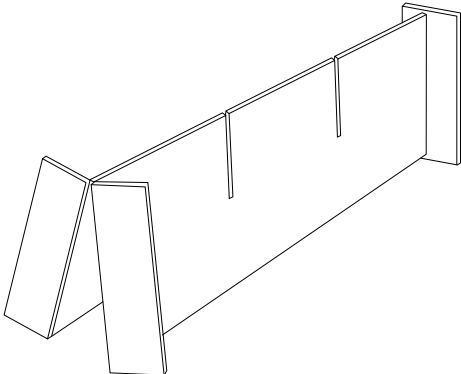
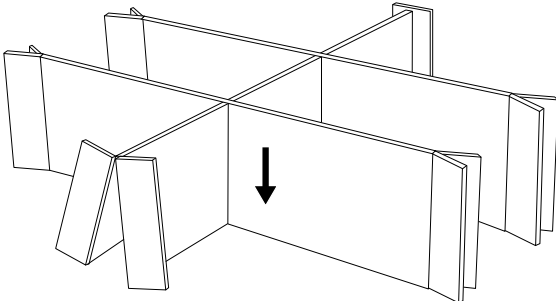

Figure 2



BOX ASSEMBLY

Figure 1

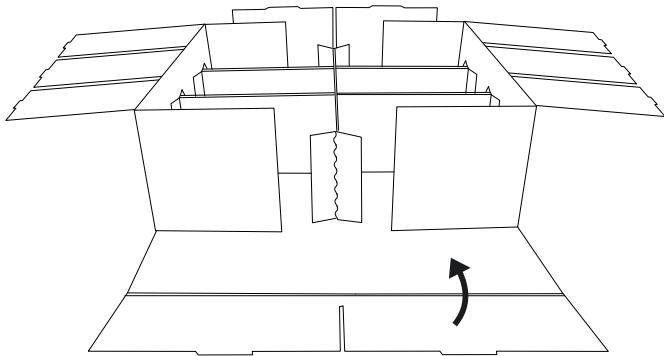

Figure 2

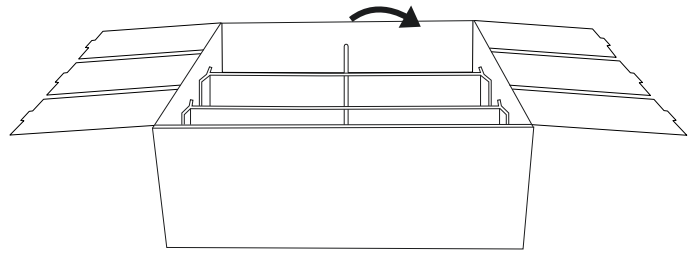

Figure 3

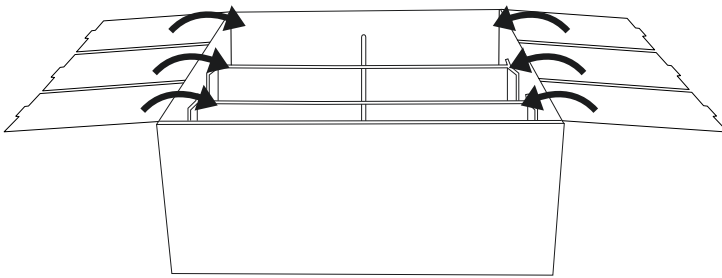

Figure 4

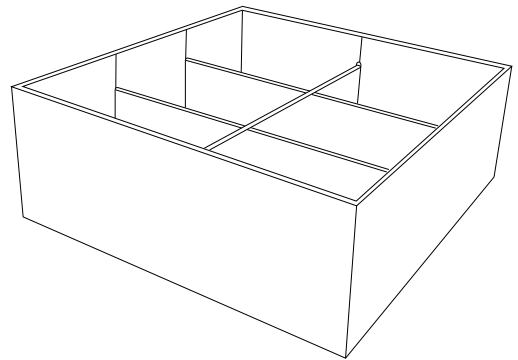
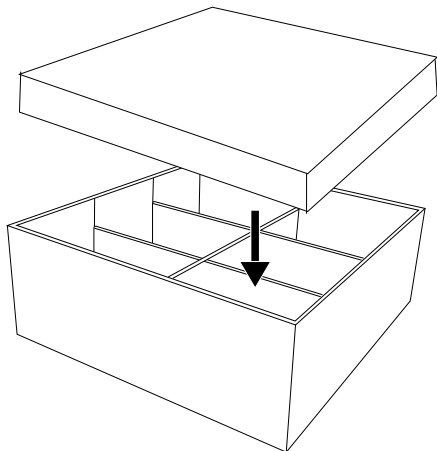

Figure 5



ULINE S-15024

**CAJA DE
ALMACENAMIENTO
PARA DVD/CD**

800-295-5510
uline.mx

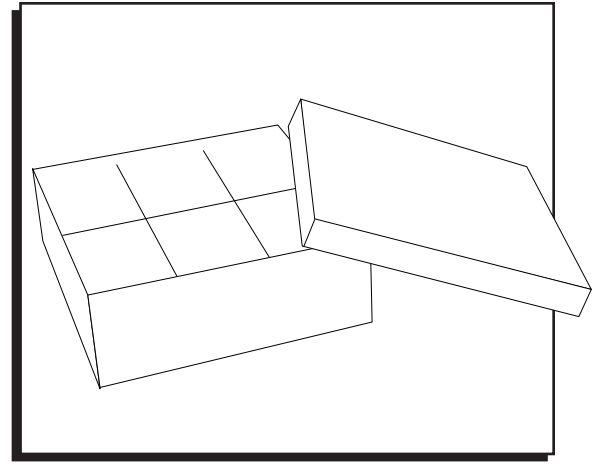

ENSAMBLE DE LA TAPA

Diagrama 1



Diagrama 2



Diagrama 3

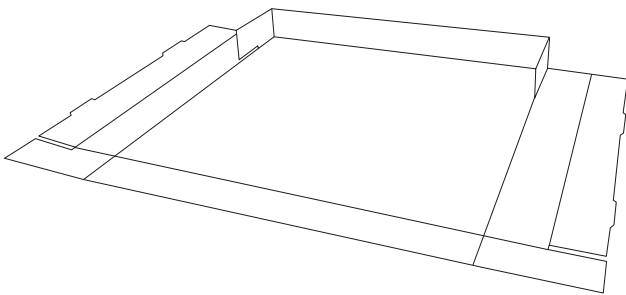

ENSAMBLE DE COMPARTIMENTOS

Diagrama 1

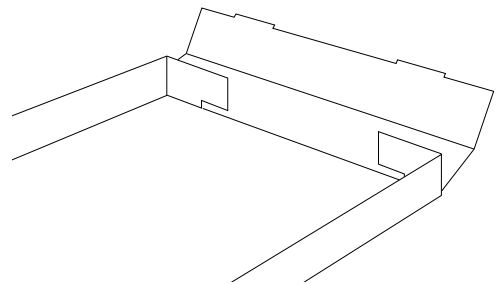
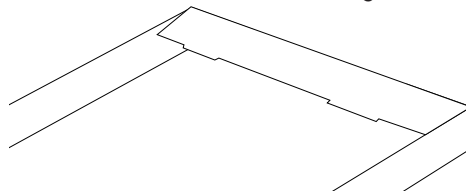

Diagrama 2



ENSAMBLE DE LA CAJA

Diagrama 1

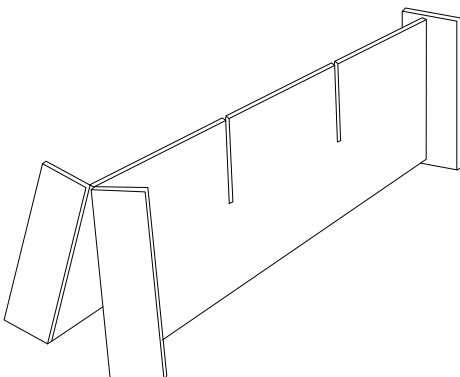
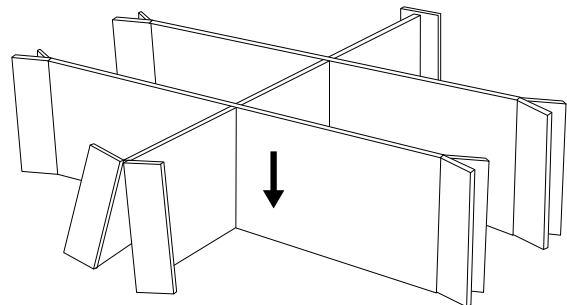

Diagrama 2



Diagrama 3

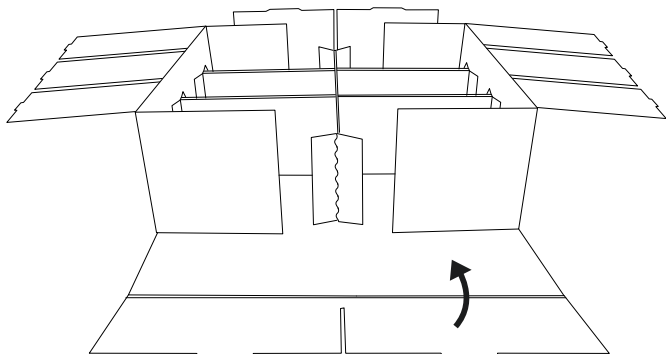

Diagrama 4

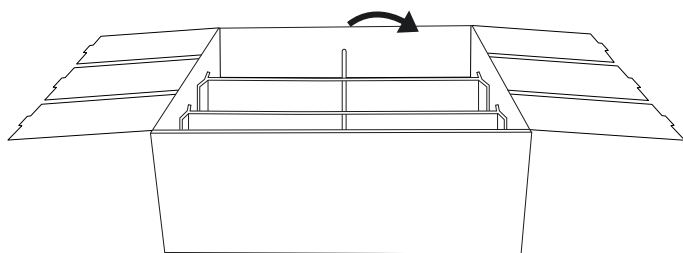

Diagrama 5

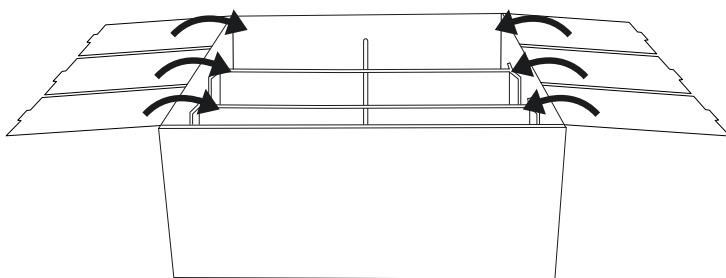

ULINE S-15024
BOÎTE D'ENTREPOSAGE
POUR DVD/CD

1-800-295-5510
uline.ca

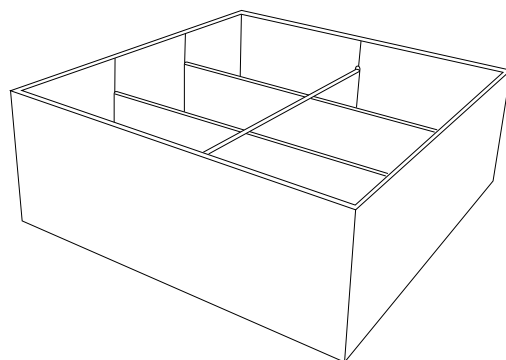
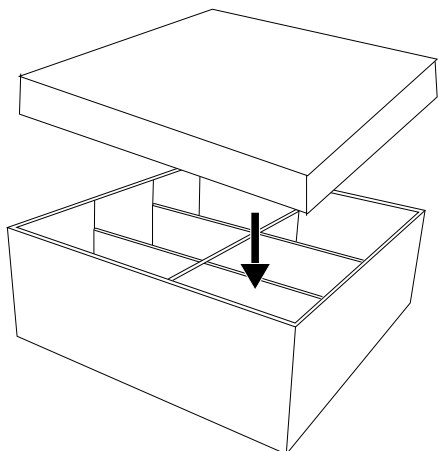
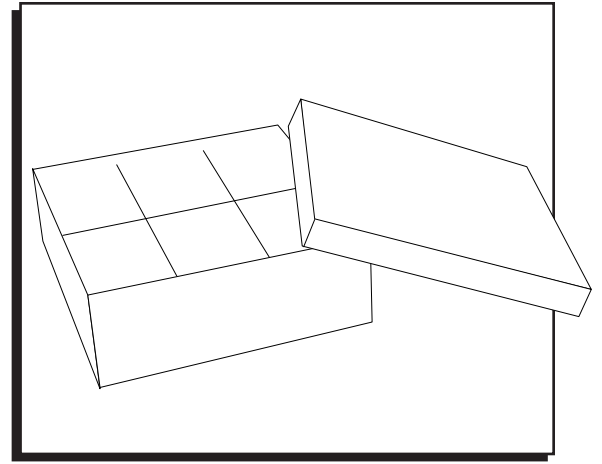

ASSEMBLAGE DU COUVERCLE

Figure 1

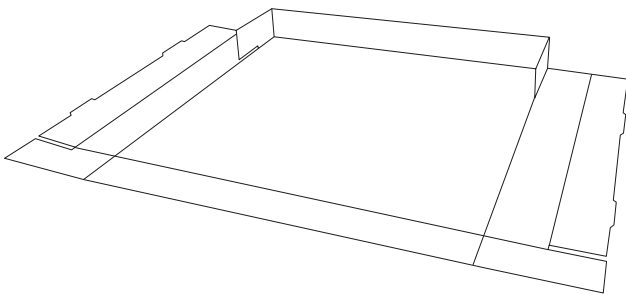

Figure 2

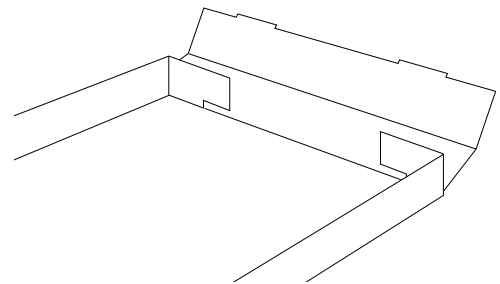
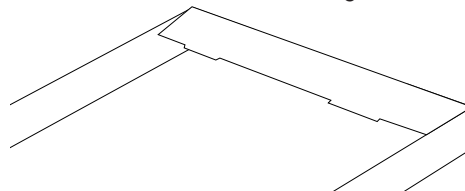

Figure 3



ASSEMBLAGE DES SÉPARATEURS

Figure 1

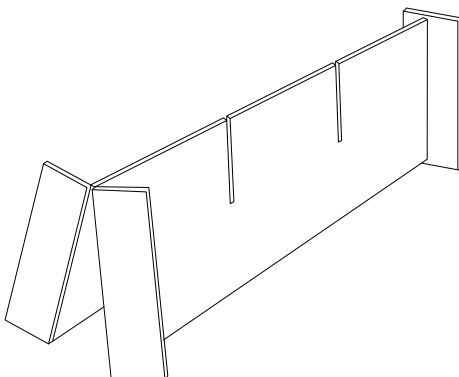
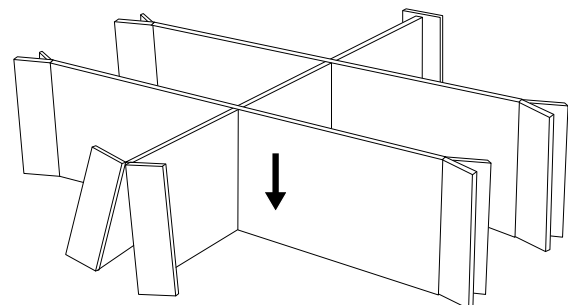

Figure 2



ASSEMBLAGE DE LA BOÎTE

Figure 1

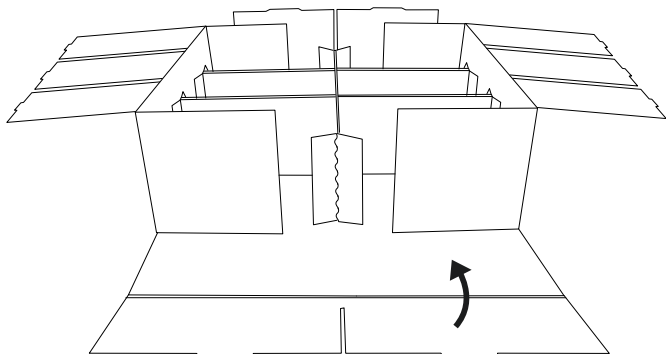

Figure 2

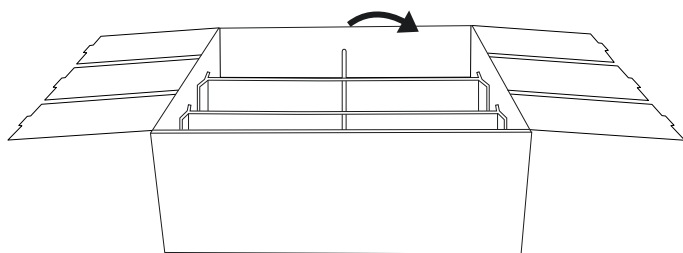

Figure 3

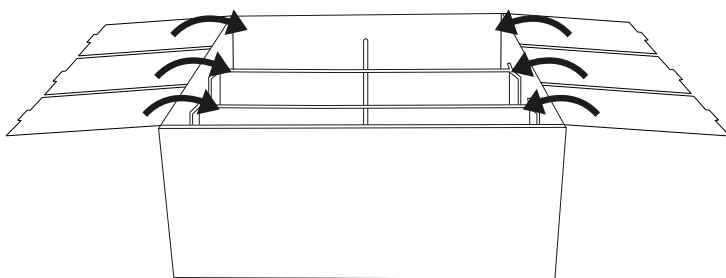

Figure 4

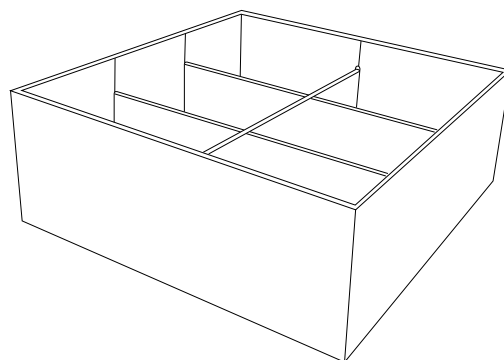

Figure 5

