

ULINE S-10714

ELECTRONICS SYSTEM SUSPENSION BOX KIT

1-800-295-5510
uline.com

PARTS INCLUDED

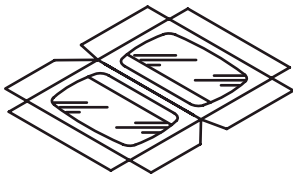

Frame

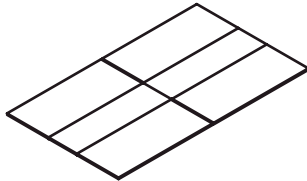

Shipping Box

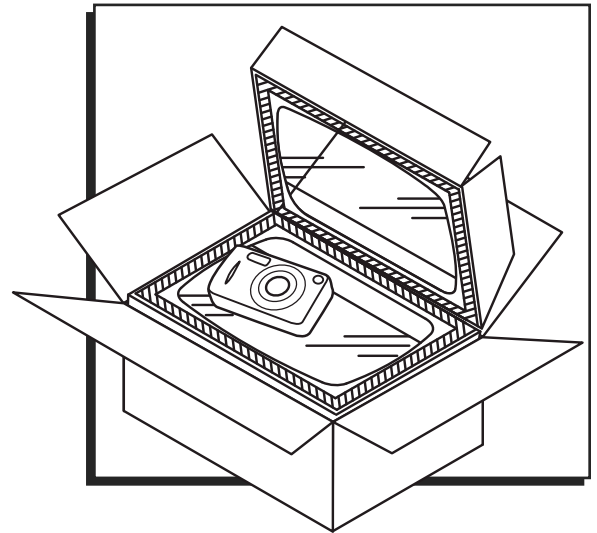

INSTRUCTIONS

1. Place frame film side down. Fold panels to pre-fold frame. Remove center pieces. (See Figure 1)

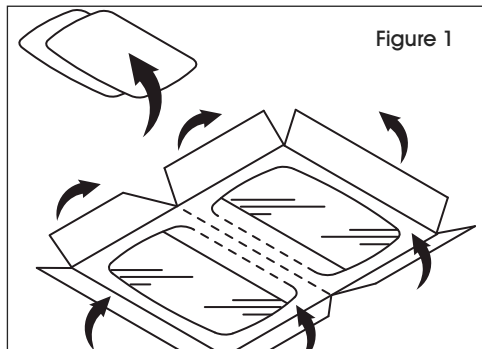

Figure 1

2. Flip over and fold hinge and doors. (See Figure 2)

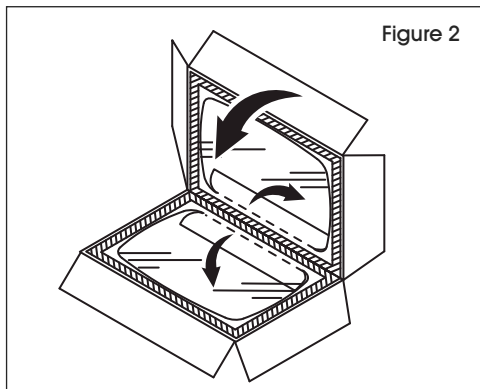

Figure 2

3. With film side up, fold hinge and hold sides to insert into box. (See Figure 3)

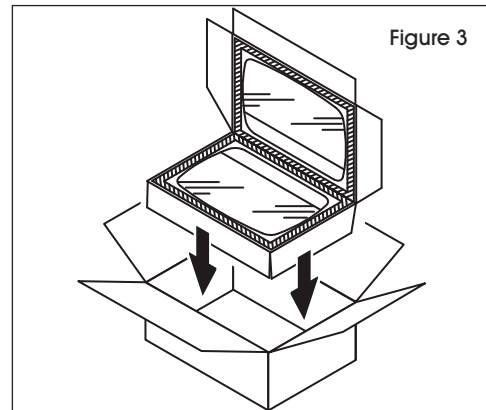

Figure 3

4. Place product centered on film. Fold top frame to compress product. (See Figure 4)



NOTE: Product must be compressed between film.

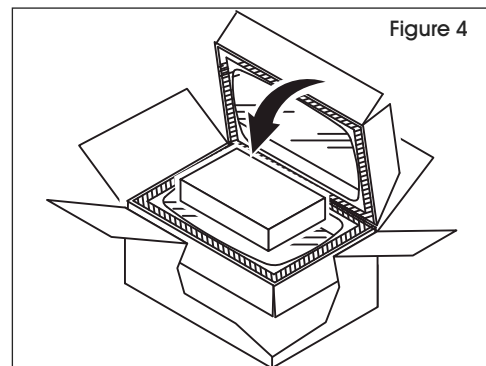

Figure 4

ULINE S-10714

KIT DE CAJA DE SUSPENSIÓN PARA SISTEMAS ELECTRÓNICOS

800-295-5510
uline.mx

PARTES INCLUIDAS

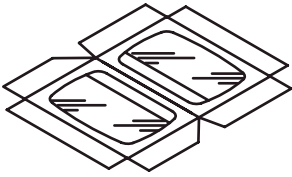

Marco

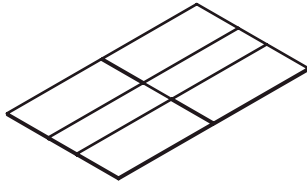

Caja de Envío

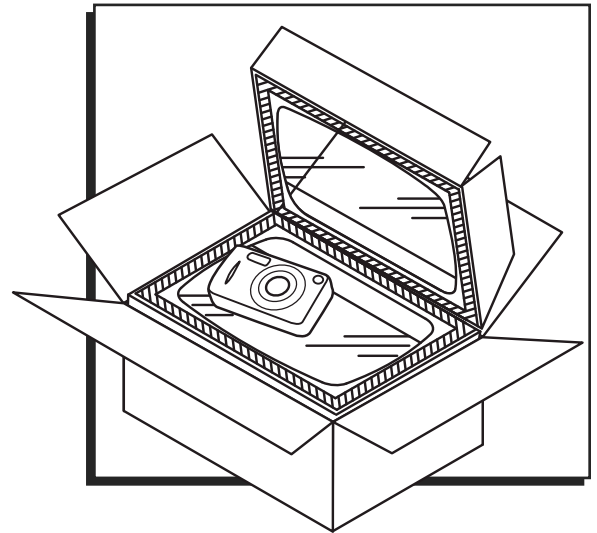

INSTRUCCIONES

1. Coloque el marco con el lado de la película hacia abajo. Doble los paneles por la parte premarcada del marco. Remueva las piezas centrales. (Vea Diagrama 1)

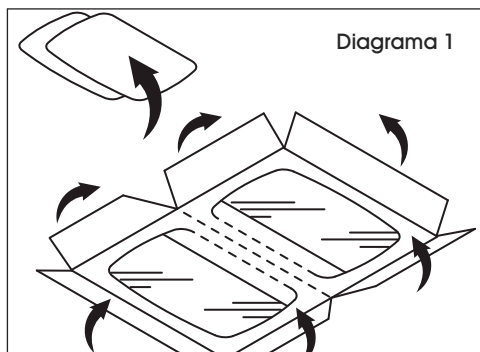

2. Voltee y doble la bisagra y las puertas. (Vea Diagrama 2)

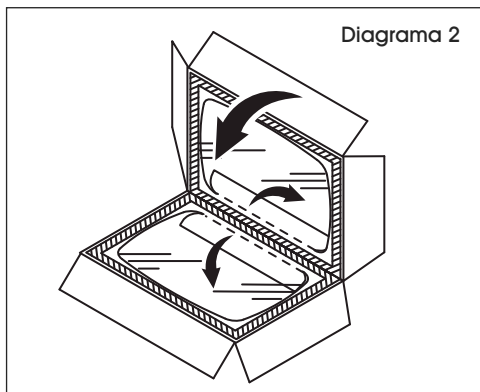

3. Con la cara de la película hacia arriba, doble por la bisagra y sostenga los laterales para insertarlos en la caja. (Vea Diagrama 3)

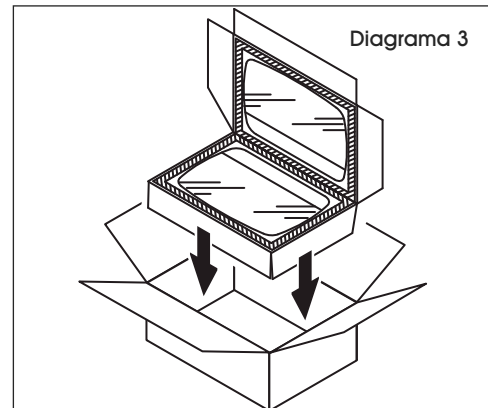

4. Coloque el producto centrado sobre la película. Doble el marco superior para comprimir el producto. (Vea Diagrama 4)

 **NOTA:** El producto debe quedar comprimido entre las películas.

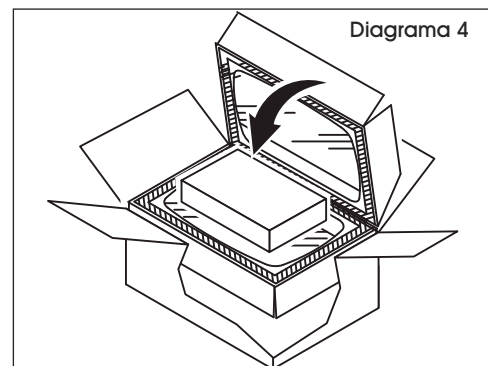

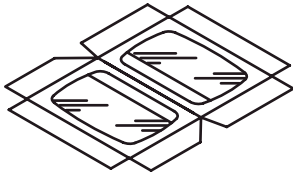
**BOÎTE À SUSPENSION
DE SYSTÈMES
ÉLECTRONIQUES****PIÈCES COMPRISES**

Cadre

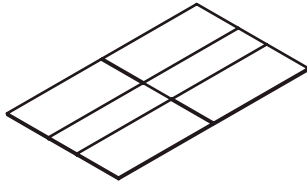

Boîte d'expédition

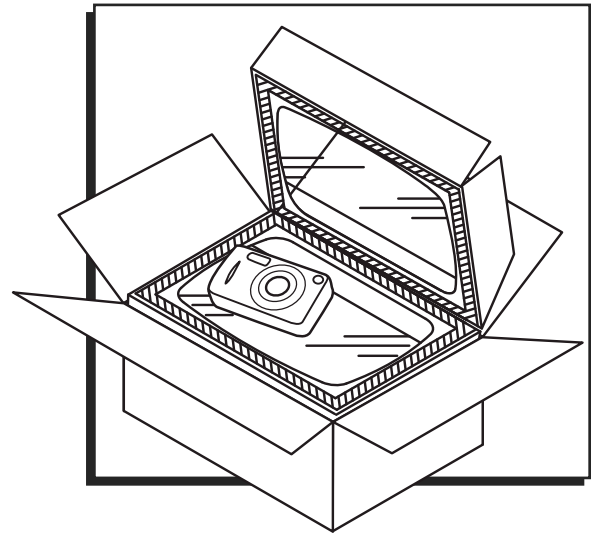
**INSTRUCTIONS**

1. Placez le cadre en orientant la partie avec la pellicule vers le bas. Pliez les panneaux pour former le cadre. Retirez les morceaux se trouvant au centre. (Voir Figure 1)

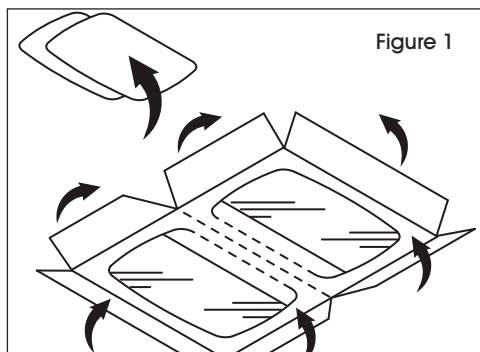

Figure 1

2. Retournez et pliez la charnière et les portes. (Voir Figure 2)

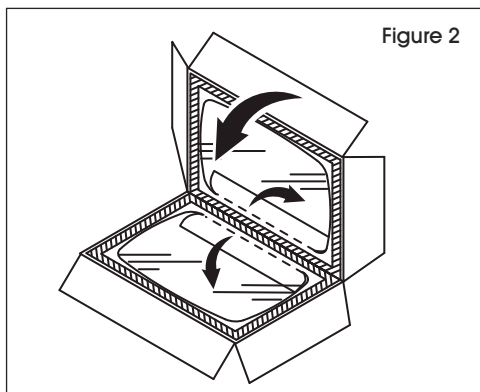

Figure 2

3. En orientant la partie avec la pellicule vers le haut, pliez la charnière et tenez les côtés pour l'insérer dans la boîte. (Voir Figure 3)

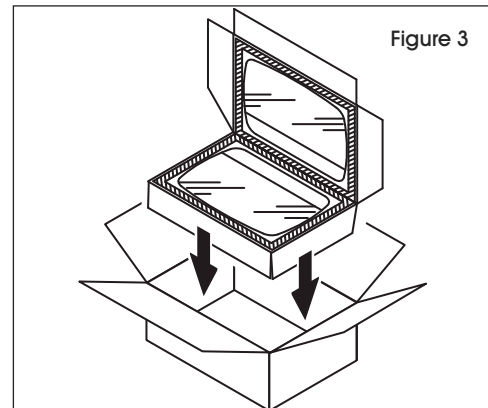

Figure 3

4. Placez le produit au centre de la pellicule. Repliez le cadre supérieur pour comprimer le produit. (Voir Figure 4)



REMARQUE : Le produit doit être comprimé entre les deux pellicules.

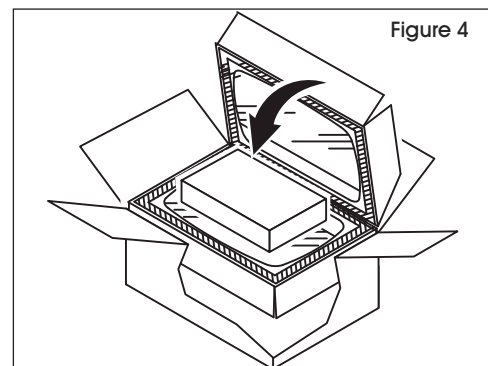

Figure 4