

# CM<sup>®</sup> HTP-HTG TROLLEY

Available in 1/2 through 20 ton capacities • Plain or Geared-Type



**Follow all instructions and warnings for inspecting, maintaining and operating this trolley.**

The use of any trolley presents some risk of personal injury or property damage. That risk is greatly increased if proper instructions and warnings are not followed. Before using this trolley, each operator should become thoroughly familiar with all warnings, instructions and recommendations in this manual. Retain this manual for future reference and use.

**Forward this manual to the trolley operator.** Failure to operate the equipment as directed in this manual may cause injury. Should you have any questions regarding this product, please call Columbus McKinnon.

**The hoisting equipment described in this manual is intended for industrial use only and should not be used to lift, support or otherwise transport people.**

## GENERAL INFORMATION:

ANSI B30.11 compliant. The HTP-HTG series trolleys are designed to be used with several Columbus McKinnon hoists up to a capacity of 20 metric tons. Please review hoist hook and trolley dimensions carefully to ensure hoist will adapt to trolley without need for additional rigging.

## LOAD RATINGS:

Before installing, make certain the capacity of the hoist does not exceed the capacity of the trolley and the supporting structure is capable of supporting the load, hoist and trolley.

## INSTALLATION:

HTP-HTG trolleys can be mounted on either American Standard Beams or Wide-Flange Beams. See flange adjustment range charts contained within this manual.

## MAINTENANCE / INSPECTION:

The trolley should be inspected periodically for evidence of excess wear or overload and its continued ability to support the load. The frequency of inspection will depend on the severity of use. It is recommended that the user begin with a monthly inspection and extend periods to quarterly, semi-annually or annually based on monthly experience. **Any worn parts should be replaced immediately.** The trolley should be visually inspected for the following conditions: loose hardware, sideplate damage or bending, cracks or distortion, wheel wear or cracks and worn bearings.

**ULINE** H-9942

1-800-295-5510

1221 IH-9942VND

**CM HOIST PARTS AND SERVICES ARE AVAILABLE IN THE UNITED STATES AND CANADA**

PARTS FOR YOUR HOIST ARE AVAILABLE FROM YOUR LOCAL AUTHORIZED REPAIR STATION.

FOR THE NAME OF THE NEAREST PARTS OR SERVICE CENTER, VISIT OUR WEB SITE  
[WWW.COLUMBUSMCKINNON.COM](http://WWW.COLUMBUSMCKINNON.COM) OR CALL OUR CUSTOMER SERVICE DEPARTMENT AT 800-888-0985.

AN ELECTRONIC COPY OF THIS MANUAL AND THE CM HOIST PARTS AND SERVICES LIST IS AVAILABLE AT:

**[WWW.COLUMBUSMCKINNON.COM](http://WWW.COLUMBUSMCKINNON.COM)**



**Follow all instructions and warnings for inspecting, maintaining, and operating this hoist.**

**ULINE** H-9942

1-800-295-5510

1221 IH-9942VND

## INTRODUCTION

Products of CMCO Industrial Products GmbH have been built in accordance with the state-of-the-art and generally accepted engineering standards. Nonetheless, incorrect handling when using the products may cause dangers to life and limb of the user or third parties and/or damage to the hoist or other property.

The operating company is responsible for the proper and professional instruction of the operating personnel. For this purpose, all operators must read these operating instructions carefully prior to the initial operation.

These operating instructions are intended to acquaint the user with the product and enable him to use it to the full extent of its intended capabilities. The operating instructions contain important information on how to operate the product in a safe, correct and economic way. Acting in accordance with these instructions helps to avoid dangers, reduce repair costs and downtimes and to increase the reliability and lifetime of the product. The operating instructions must always be available at the place where the product is operated. Apart from the operating instructions and the accident prevention act valid for the respective country and area where the product is used, the commonly accepted regulations for safe and professional work must also be adhered to.

The personnel responsible for operation, maintenance or repair of the product must read, understand and follow these operating instructions.

The indicated protective measures will only provide the necessary safety, if the product is operated correctly and installed and/or maintained according to the instructions. The operating company is committed to ensure safe and trouble-free operation of the product.

## CORRECT OPERATION

The hoist is used for overhead horizontal moving of suspended loads up to the indicated max. load capacity.

**ATTENTION: The unit may be used only in situations in which the load carrying capacity of the device and/or the supporting structure does not change with the load position.**

Any different or exceeding use is considered incorrect. Columbus McKinnon Industrial Products GmbH will not accept any liability for damage resulting from such use. The risk is borne by the user or operating company alone.

The load capacity indicated on the unit is the maximum working load limit (WLL) that may be attached.

The selection and calculation of the appropriate supporting structure are the responsibility of the operating company.

The attachment point and its supporting structure must be designed for the maximum loads to be expected (deadweight of the unit + load capacity).

The hoist is suitable for a wide range of beams as well as for various profiles (e.g. INP, IPE, IPB, etc.) with a max. inclination of the beam flange which does not exceed 14°.

The runway and its supporting structure must be designed for the maximum loads to be expected (deadweight of the unit + load capacity). The runway must only have a deflection of max. 1/500 of the span.

The longitudinal gradient of the travel path surface may not exceed 0.3%.

The air gap between the wheel flange and the beam flange ("dimension A") must range between 1.0 and 2.5 mm on either side of the trolley (depends on model).

Once the trolley width has been adjusted, the clevis of the load bar must be in the illustrated position relevant to the beam. The top hook of the hoist must only be hung into the clevis in this condition. The weight of the hoist automatically secures the adjustment of the trolley.

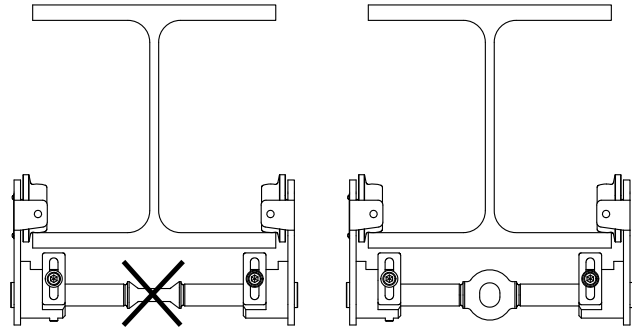

Figure 1.

Once the trolley width has been adjusted, the clevis of the load bar must be in the illustrated position relevant to the beam. The top hook of the hoist must only be hung into the clevis in this condition. The weight of the hoist automatically secures the adjustment of the trolley.

The operator must ensure that the hoist is suspended in a manner that makes it possible to operate the unit without exposing himself or other personnel to danger by the unit itself, the suspension or the load.

The operator may start moving the load only after it has been attached correctly and all persons are clear of the danger zone.

Do not allow personnel to stay or pass under a suspended load.

A lifted or clamped load must not be left unattended or remain lifted or clamped for a longer period of time.

Loads suspended from a trolley without a gear drive must be pushed. The load must not be pulled.

If the area in front of the load is not sufficiently visible, the operator must ensure he is given help.

The hoist may be used at ambient temperatures between -10° and +50°C. Consult the manufacturer in the case of extreme working conditions.

Prior to operation of the hoist in special atmospheres (high humidity, salty, caustic, alkaline) or handling hazardous goods (e.g. molten compounds, radioactive materials), consult the manufacturer for advice.

Always transport the load in the horizontal direction slowly, carefully and close to the ground.

Only use safety hooks with safety latches.

For attaching a load, only approved and certified lifting tackle must be used.

Correct operation involves compliance with the operating instructions and in addition also compliance with the maintenance instructions.

In case of functional defects or abnormal operating noise, stop using the hoist immediately.

## INCORRECT OPERATION

(List not complete)

Do not exceed the rated load capacity (WLL) of the unit and/or the suspension and the supporting structure.

Removing or covering labels (e.g. by adhesive labels), warning information signs or the identity plate is prohibited.

When transporting loads ensure that the load does not swing or come into contact with other objects.

The load must not be moved into areas which are not visible to the operator. If necessary, he must ensure he is given help.

The unit must never be operated with more than the power of a person.

Welding work on the unit is prohibited. The unit must never be used as a ground connection during welding.

Side pull, i. e. side loading of the side plates and/or the load bar

is forbidden. The trolley must be perpendicular above the load at any time.

A unit changed without consulting the manufacturer must not be used.

Do not use the hoist for the transportation of people.

Incorrect attachment to or incorrect loading of the clevis load bar, i. e. applying load to the "flat" side of the suspension eye, is forbidden.

Enlarging the adjusted trolley width, e. g. to enable the trolley to negotiate smaller curve radii, is forbidden.

Only units fitted with hooks with safety latches must be suspended in the clevis of the load bar. Make sure that the hook is not too large. The clevis must be seated centrally in the saddle of the hook and the hook must be freely articulating in the clevis at the same time.

Only one load lifting attachment or hoist may be suspended in the clevis of the trolley load bar.

Never reach into moving parts.

Do not allow the unit to fall from a large height. Always place it properly on the ground.

The unit must not be used in potentially explosive atmospheres (special models on request).

## ASSEMBLY

### INSPECTION OF THE SUPPORTING STRUCTURE

The supporting structure has to be selected to ensure that it has sufficient stability and the expected forces can be safely absorbed.

Make sure that no impermissible additional loading may occur as a result of fitting the hoist (e.g. by side pull).

The selection and calculation of the appropriate supporting structure are the responsibility of the operating company.

### HTP/HTG .5 - 5 T

1. Screw the end of the clevis load bar marked "L" (left-hand thread) approx. .12" into the side plate also marked "L". The trolley wheels point in the direction of the clevis.
2. Screw the second side plate with the trolley wheels also pointing in the direction of the clevis approx. .12" onto the other end of the clevis load bar.
3. Screw the clevis load bar further into the side plates until both ends protrude over the side plates on the outer sides.

In addition for type B

4. Screw the limit stop screws with the spring washers and the cylinder screws onto the ends of the clevis load bar in accordance with Fig. 8. They prevent unintentional turning of the clevis load bar when the trolley is adjusted to the maximum trolley width and must always be fitted.
5. By rotating the clevis load bar further, the trolley width is roughly pre-adjusted to the required beam size.
6. If the beam intended for assembly has an accessible open end, assemble the trolley on the ground and slide it onto the beam at the open end. If the intended supporting structure has no open end, increase the distance between the side plates by turning the clevis load bar to the extent that the wheels can be lifted over the beam flange and can be set down on it. If the distance of the wheels cannot be opened wide enough, remove one of the side plates and refit it on the beam.
7. The distance of the wheel to the beam flange (dimension "A", Tab. 1) is then precisely adjusted by turning the load bar.
8. After assembly of the trolley on the supporting structure, fit the end stops on the beam.

**ATTENTION:** With the max. permissible flange width for the trolley, both ends of the clevis load bar must at least be flush with the side plates.

Only on type B up to 5000 kg

9. Adjustment of the anti-tilt device :

Loosen the cylinder screws and push the link plates in the direction of the lower side of the beam, so that they have a distance of .12" to max. .20" to the beam over the entire travel path.

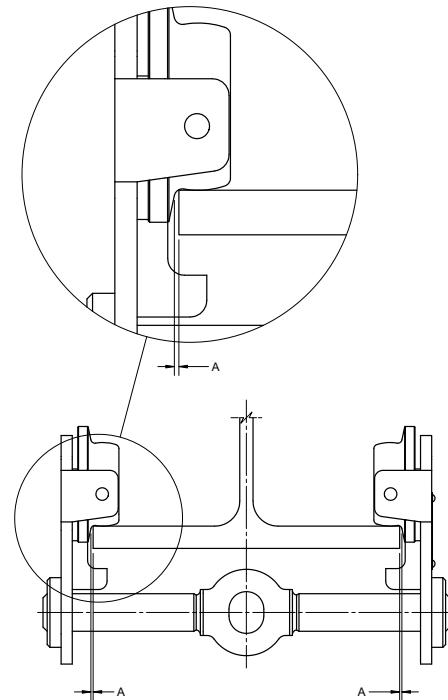

**Figure 2.**

Once the trolley width has been adjusted, the clevis of the load bar must be in the illustrated position relevant to the beam. The top hook of the hoist must only be hung into the clevis in this condition. The weight of the hoist automatically secures the adjustment of the trolley.

### HTG 10 - 20 T

1. Measure the flange width of the beam.
2. Evenly distribute the spacer sleeves and spacer washers on both sides of the clevis load bar in accordance with the flange width. The correct distance between the trolley wheel flange and the beam flange must be maintained to either side (dimension "A", Tab. 1).
3. After adjustment of the inner dimension, evenly distribute the remaining spacer sleeves and spacer washers on the outside of the side plates on the ends of the load bar. In each case, at least 3 washers and 1 sleeve must be mounted between the side plates and the castle nuts.

**Tip:** For easier assembly, tighten one side plate, distribute the required combination of spacer sleeves and spacer washers, the clevis and the remaining spacer sleeves and spacer washers on the load bars and place the other side plate onto the load bars. Screw on castle nuts without tightening.

4. If the beam intended for assembly has an accessible open end, assemble the trolley on the ground and slide it onto the beam at the open end. If the intended supporting structure has no open end, increase the distance between the side plates temporarily to the extent that the wheels can be lifted over the beam flange and can be set down on it. If the distance of the wheels cannot be opened wide enough, remove one of the side plates and refit it on the beam.
5. When the correct distance between the side plates has been set, tighten all castle nuts.
6. Secure all castle nuts with cotter pins.

**ATTENTION:** A trolley must never be used on a beam with a flange width that exceeds the maximum adjustable width of the trolley (observe total clearance of .20", depends on model) or with a profile which does not correspond to the profile the trolley has been designed for.

### **Shorten or extend the hand chain (model HTG only and all trolleys with locking device)**

Adjust the length of the hand chain so that the distance of the lower end to the floor is between 1.5 to 3 ft.

**NOTE: For safety reasons, hand chain links may only be used once.**

- Look for the non-welded link of the hand chain, bend to open and discard it.
- Shorten or extend the chain to the required length.

**ATTENTION: Always remove or add an even number of chain links.**

- Use a new link to close the loose chain ends by bending it (for extending the hand chain, two new chain links are required).

**ATTENTION: Make sure that hand chains are not twisted while they are fitted.**

**Fitting the hand chain (model HTG only and models with locking device)**

To fit the hand chain, position the slot on the outer edge of the hand chain wheel below the chain guides. Place one chain link of the endless hand chain vertically into the slot and turn the hand chain wheel until the chain has passed the chain guides on both sides.

**ATTENTION: Do not twist hand chains while fitting.**

## **INSPECTION BEFORE INITIAL OPERATION**

Prior to initial operation, before it is put into operation again and after substantial changes, the product including the supporting structure must be inspected by a competent person\*. The inspection mainly consists of a visual inspection and a function check. These inspections are intended to establish that the hoist is in a safe condition, has been set up appropriately and is ready for operation and that any defects or damage are detected and eliminated, as required.

\*Competent persons may be, for example, the maintenance engineers of the manufacturer or the supplier. However, the company may also assign performance of the inspection to its own appropriately trained specialist personnel.

## **INSPECTION BEFORE STARTING WORK**

Before starting work, inspect the unit including the suspension, equipment and supporting structure for visual defects, e. g. deformations, damage, cracks, wear and corrosion marks.

In addition also check that hoist and/or load are correctly attached.

## **INSPECTION OF THE SUPPORTING STRUCTURE**

The supporting structure has to be selected to ensure that it has sufficient stability and the expected forces can be safely absorbed.

Make sure that no impermissible additional loading may occur as a result of fitting the hoist (e.g. by side pull).

The selection and calculation of the appropriate supporting structure are the responsibility of the operating company.

## **INSPECTION OF THE TROLLEY**

- The clevis of the load bar must be exactly in the middle between the side plates so that the side plates are evenly loaded.
- Check the adjustment of the anti-tilt device (only type B), the adjustment of the trolley width and the correct assembly of the clevis load bar.
- The side plates must be parallel to each other.
- All wheels must be in contact with the beam flange.

**ATTENTION: The trolley must never be used on beams with flange widths that exceed the maximum adjustable width of the trolley.**

## **CHECKING THE TRAVEL PATH**

Before starting work, check the unit for faultless passage on the beam. Any existing obstacles must be eliminated.

In addition, check the correct fastening and position of the end stops.

Before travelling trolleys with locking device (optional), make sure that the locking device is turned open up to the end stop so that no friction or sparks may be caused. Only then may the trolley be moved.

**Attention: In particular in curved sections, make sure that the stop of the locking device (optional) does not come into contact with the beam flange!**

## **INSPECTION OF THE LOAD BAR**

The load bar must be checked for cracks, deformations, damage, wear and corrosion marks. In particular, check the material thickness of the suspension eye in the load bar. The load bar must be replaced as soon as the material thickness of the clevis deviates from the nominal dimension by 5% as a result of wear.

## **SHORTEN OR EXTEND THE HAND CHAIN (MODEL HTG ONLY AND ALL TROLLEYS WITH LOCKING DEVICE)**

Adjust the length of the hand chain so that the distance of the lower end to the floor is between 1.5 to 3 ft.

## **OPERATION**

### **INSTALLATION, SERVICE, OPERATION**

Operators delegated to install, service or independently operate the hoist must have had suitable training and be competent. Operators are to be specifically nominated by the company and must be familiar with all relevant safety regulations of the country of use.

### **TRAVELLING THE PUSH-TYPE TROLLEY HTP**

The push-type trolley is actuated by pushing the attached load or the suspended load lifting attachment. It must not be pulled.

### **TRAVELLING THE GEARED-TYPE TROLLEY HTG**

Geared-type trolleys are moved by pulling the appropriate hand chain fall.

### **OPERATION OF THE LOCKING DEVICE (OPTIONAL)**

The locking device is exclusively used for easily locking the unloaded trolley (parking position in the shipping sector, for example). The brake shoe is pressed against the beam flange by pulling on the appropriate hand chain fall so that the chain wheel turns clockwise. Only tighten the chain by hand for this process. The locking device is released again by pulling on the other chain fall.

### **SECURING THE LOAD BAR (ONLY TYPE B)**

If the trolley has been adjusted to the correct width, the load bar can be fixed with the locking screw (Fig. 8, item 11).

## **INSPECTION, SERVICE & REPAIR**

According to national and international accident prevention and safety regulations load lifting attachments must be inspected:

- in accordance with the risk assessment of the operating company
- prior to initial operation
- before the unit is put into service again following a shut down
- after substantial changes
- however, at least once per year, by a competent person.

**ATTENTION: Actual operating conditions (e.g. operation in galvanizing facilities) can dictate shorter inspection intervals.**

Repair work may only be carried out by a specialist workshop that uses original Yale spare parts. The inspection (mainly consisting of a visual inspection and a function check) must determine that all safety devices are complete and fully operational and cover the condition of the unit, suspension, equipment and supporting structure with regard to damage, wear, corrosion or any other alterations.

Initial operation and recurring inspections must be documented (e.g. in the CMCO works certificate of compliance).

If required, the results of inspections and appropriate repairs must be verified. If the hoist (from 1 t lifting weight) is fitted on or in a trolley and if the hoist is used to move a lifted load in one or several directions, the installation is considered to be a crane and the further inspections must be carried out, as required.

Paint damage should be touched up in order to avoid corrosion. All joints and sliding surfaces should be slightly greased. In the case of heavy contamination, the unit must be cleaned.

For the models with gear drive, ensure that the drive shaft and geared wheels are sufficiently greased at all times.

The unit must be given a general overhaul after 10 years, at the latest.

**ATTENTION: After the replacement of components, a subsequent inspection by a competent person is obligatory!**

**ATTENTION: Chains must only be replaced by chains of the same material, with the same quality and the same dimensions.**

## **INSPECTION OF THE CLEVIS OF THE LOAD BAR**

Inspect the clevis of the load bar for deformation, damage, surface cracks, wear and signs of corrosion as required but at least once a year. Actual operating conditions may also dictate shorter inspection intervals.

If a clevis must be discarded as a result of an inspection, a new load bar must be fitted. Welding on load bar and/or clevis, e.g. to compensate for wear or damage, is not permissible. The load bar with clevis must be replaced at the latest, if the material diameter is 5% smaller than the nominal diameter.

## **REPLACING THE HAND CHAIN (ONLY TROLLEY WITH GEAR DRIVE)**

- An open load chain link is required as a tool. It can be obtained by using an abrasive wheel to cut a section from an existing link with the same dimension. The length of the cut section must at least correspond to the thickness of the link.
- Open the old hand chain (preferably on the connection link) and suspend the open link into the loose end of the hand chain which lies "in front of" the hand chain wheel.
- Suspend the new hand chain also in the open link and pull it through the chain guides and over the hand chain wheel.
- Do not fit a twisted chain. The welds must face outwards.
- Separate the old hand chain including the open connection link from the new hand chain and connect the two loose ends of the new hand chain by means of a new hand chain connection link.

**Repairs may only be carried out by authorized specialist workshops that use original Yale spare parts.**

After repairs have been carried out and after extended periods of non-use, the hoist must be inspected again before it is put into service again.

**The inspections have to be initiated by the operating company.**

## **TRANSPORT, STORAGE, DECOMMISSIONING AND DISPOSAL**

### **OBSERVE THE FOLLOWING FOR TRANSPORTING THE UNIT:**

- Do not drop or throw the unit, always deposit it carefully.
- Hand chains must be transported in a way to avoid knotting and formation of loops.
- Use suitable transport means. These depend on the local conditions.

### **OBSERVE THE FOLLOWING FOR STORING OR TEMPORARILY TAKING THE UNIT OUT OF SERVICE:**

- Store the unit at a clean and dry place.
- Protect the unit incl. all accessories against contamination, humidity and damage by means of a suitable cover.
- Apply a light lubricant film to the chain(s).
- Protect the load bar against corrosion by greasing or oiling.
- Slightly grease the accessible gear wheels.
- If the unit is to be used again after it has been taken out of service, it must first be inspected again by a competent person.

### **DISPOSAL**

After taking the unit out of service, recycle or dispose of the parts of the unit in accordance with the legal regulations.

# HTP-HTG TROLLEYS

Figure 3.

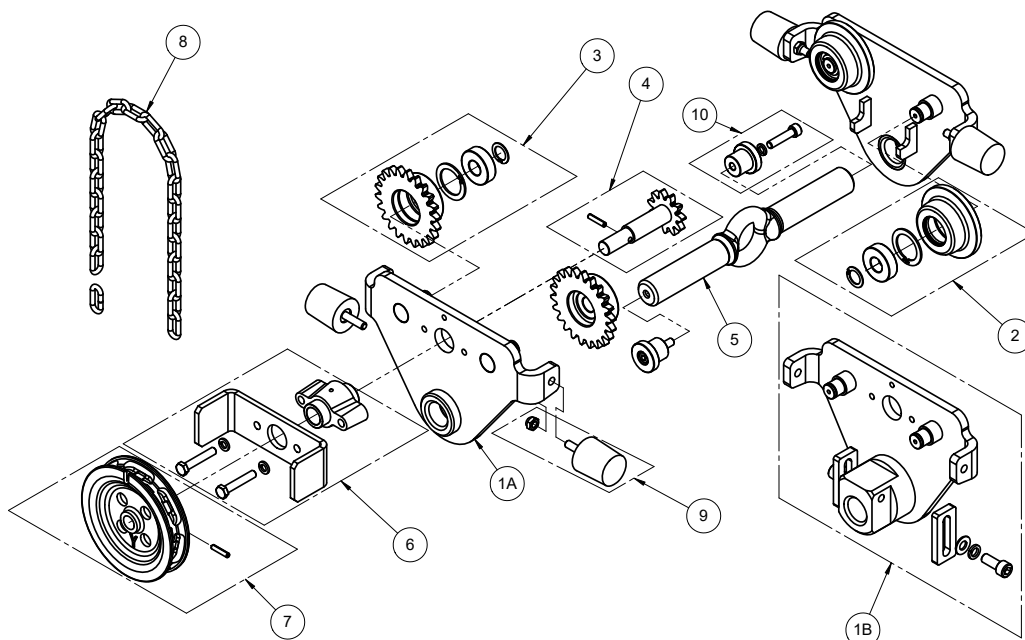

Item No.	Part No.	Description
1A	HTGA0001-50	Side Plate, .5 ton
	HTGA0001-1	Side Plate, 1 ton
	HTGA0001-2	Side Plate, 2 ton
	HTGA0001-3	Side Plate, 3 ton
	HTGA0001-5	Side Plate, 5 ton
1B	HTGB0001-50	Side Plate, .5 ton
	HTGB0001-1	Side Plate, 1 ton
	HTGB0001-2	Side Plate, 2 ton
	HTGB0001-3	Side Plate, 3 ton
	HTGB0001-5	Side Plate, 5 ton
2	HTG0002-1	Trolley Wheel, Plain, .5 & 1 ton
	HTG0002-2	Trolley Wheel, Plain, 2 ton
	HTG0002-3	Trolley Wheel, Plain, 3 ton
	HTG0002-5	Trolley Wheel, Plain, 5 ton
3	HTG0003-1	Trolley Wheel, Geared, .5 & 1 ton
	HTG0003-2	Trolley Wheel, Geared, 2 ton
	HTG0003-3	Trolley Wheel, Geared, 3 ton
	HTG0003-5	Trolley Wheel, Geared, 5 ton
4	HTG0004	Drive Shaft, .5 thru 5 ton
5	HTG0005-50	Clevis Load Bar, .5 ton
	HTG0005-1	Clevis Load Bar, 1 ton
	HTG0005-2	Clevis Load Bar, 2 ton
	HTG0005-3	Clevis Load Bar, 3 ton
	HTG0005-5	Clevis Load Bar, 5 ton

Item No.	Part No.	Description
6	HTG0006-50	Bearing Block Kit, .5 ton
	HTG0006-1	Bearing Block Kit, 1 ton
	HTG0006-2	Bearing Block Kit, 2 ton
	HTG0006-3	Bearing Block Kit, 3 ton
	HTG0006-5	Bearing Block Kit, 5 ton
7	HTG0007-50	Hand Chain Wheel Kit, .5 ton
	HTG0007-1	Hand Chain Wheel Kit, 1 & 2 ton
	HTG0007-3	Hand Chain Wheel Kit, 3 ton
	HTG0007-5	Hand Chain Wheel Kit, 5 ton
8	HTG0008	Chain Kit .5 thru 20 ton
9	HTG0009-1	Rubber Bumper Kit, .5 thru 3 ton
	HTG0009-5	Rubber Bumper Kit, 5 thru 20 ton
10	HTGB0010	Lock, Clevis Bar Kit

# 10-TON & 20-TON HTG TROLLEYS

Figure 4.

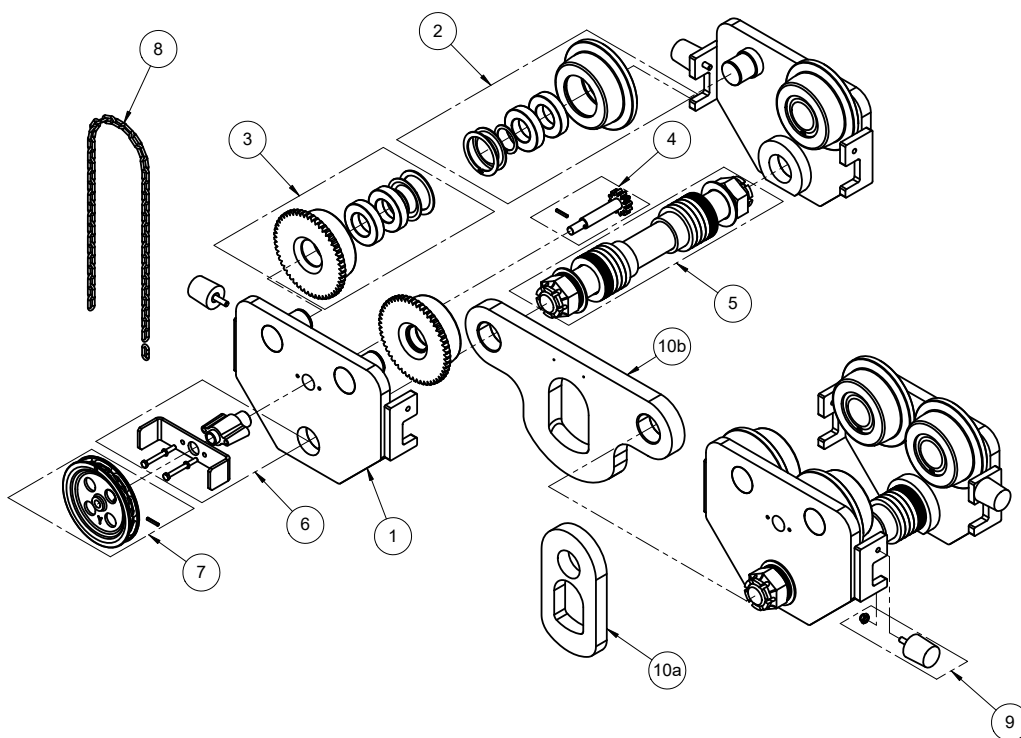

Item No.	Part No.	Description
1	HTG0001-10	Side Plate, 10 ton and above
2	HTG0002-10	Trolley Wheel, Plain, 10 ton and above
3	HTG0003-10	Trolley Wheel, Geared, 10 ton and above
4	HTG0004-10	Drive Shaft, 10 ton and above
5	HTG0005-20	Load Bar Kit, 20 ton Max
6	HTG0006-10	Bearing Bock Kit, All cap.
7	HTG0007-10	Hand Chain Wheel Kit, All cap.
8	HTG0008	Chain Kit .5 thru 20 ton
9	HTG0009-5	Rubber Bumper Kit, 5 thru 20 ton
10a	HTG0010-10	Hanging Loop, 10 ton
10b	HTG0010-20	Hanging Loop, 20 ton



# HTP-HTG TROLLEYS

Table 1.

Model	Part Number	Capacity (metric tons)	Flange Width (in)		Thickness (in)	Min Radius (in)	Weight (lbs.)
			Min	Max			
HTP 500A	HTP0050A	1/2 ton	1.97	8.67	0.99	35.43	18
HTP 1000A	HTP0100A	1 ton	1.97	8.67	0.99	35.43	20
HTP 2000A	HTP0200A	2 ton	2.60	8.67	0.99	45.28	35
HTP 3000A	HTP0300A	3 ton	2.92	8.67	0.99	55.12	71
HTP 5000A	HTP0500A	5 ton	3.55	8.67	0.99	70.87	106
HTP 500B	HTP0500B	1/2 ton	6.30	11.82	1.58	35.43	23
HTP 1000B	HTP0100B	1 ton	6.30	11.82	1.58	35.43	26
HTP 2000B	HTP0200B	2 ton	6.30	11.82	1.58	45.28	43
HTP 3000B	HTP0300B	3 ton	6.30	11.82	1.58	55.12	79
HTP 5000B	HTP0500B	5 ton	7.09	11.82	1.58	70.87	115

Table 2.

Model	Part Number	Capacity (metric tons)	Flange Width (in)		Thickness (in)	Min Radius (in)	Weight (lbs.)
			Min	Max			
HTG 500A	HTG0050A	1/2 ton	1.97	8.67	0.99	35.43	21
HTG 1000A	HTG0100A	1 ton	1.97	8.67	0.99	35.43	25
HTG 2000A	HTG0200A	2 ton	2.60	8.67	0.99	45.28	40
HTG 3000A	HTG0300A	3 ton	2.92	8.67	0.99	55.12	78
HTG 5000A	HTG0500A	5 ton	3.55	8.67	0.99	70.87	114
HTG 500B	HTG0050B	1/2 ton	6.30	11.82	1.58	35.43	28
HTG 1000B	HTG0100B	1 ton	6.30	11.82	1.58	35.43	31
HTG 2000B	HTG0200B	2 ton	6.30	11.82	1.58	45.28	47
HTG 3000B	HTG0300B	3 ton	6.30	11.82	1.58	55.12	86
HTG 5000B	HTG0500B	5 ton	7.09	11.82	1.58	70.87	123
HTG 10000B	HTG1000B	10 ton	4.93	12.21	1.58	70.87	229
HTG 20000B	HTG2000B	20 ton	4.93	12.21	1.58	196.85	507

**Table 3.**

Model	Part Number	Capacity (kg)	Flange Width (mm)		Thickness (mm)	Min Radius (m)	Weight (kg)
			Min	Max			
HTP 500A	HTP0050A	500	50	220	25	0.9	8.0
HTP 1000A	HTP0100A	1000	50	220	25	0.9	9.0
HTP 2000A	HTP0200A	2000	66	220	25	1.15	16.0
HTP 3000A	HTP0300A	3000	74	220	25	1.4	32.0
HTP 5000A	HTP0500A	5000	90	220	25	1.8	48.0
HTP 500B	HTP0500B	500	160	300	40	0.9	10.6
HTP 1000B	HTP0100B	1000	160	300	40	0.9	12.0
HTP 2000B	HTP0200B	2000	160	300	40	1.15	19.3
HTP 3000B	HTP0300B	3000	160	300	40	1.4	35.8
HTP 5000B	HTP0500B	5000	180	300	40	1.8	52.2

**Table 4.**

Model	Part Number	Capacity (kg)	Flange Width (mm)		Thickness (mm)	Min Radius (m)	Weight (kg)
			Min	Max			
HTG 500A	HTG0050A	500	50	220	25	0.9	9.7
HTG 1000A	HTG0100A	1000	50	220	25	0.9	11.2
HTG 2000A	HTG0200A	2000	66	220	25	1.15	18.0
HTG 3000A	HTG0300A	3000	74	220	25	1.4	35.4
HTG 5000A	HTG0500A	5000	90	220	25	1.8	51.8
HTG 500B	HTG0050B	500	160	300	40	0.9	12.6
HTG 1000B	HTG0100B	1000	160	300	40	0.9	14.1
HTG 2000B	HTG0200B	2000	160	300	40	1.15	21.3
HTG 3000B	HTG0300B	3000	160	300	40	1.4	39.2
HTG 5000B	HTG0500B	5000	180	300	40	1.8	56.0
HTG 10000B	HTG1000B	10000	125	310	40	1.8	104.0
HTG 20000B	HTG2000B	20000	125	310	40	5.0	230.0

# WARRANTY

## LIMITATION OF WARRANTIES, REMEDIES AND DAMAGES

### INDEMNIFICATION AND SAFE OPERATION

Buyer shall comply with and require its employees to comply with directions set forth in instructions and manuals furnished by Seller and shall use and require its employees to follow such instructions and manuals and to use reasonable care in the use and maintenance of the goods and any replacement parts. Buyer shall not remove or permit anyone to remove any warning or instruction signs on the goods or replacement parts. In the event of personal injury or damage to property or business arising from the use of the goods or replacement parts, Buyer shall within 48 hours thereafter give Seller written notice of such injury or damage. Buyer shall cooperate with Seller in investigating any such injury or damage and in the defense of any claims arising therefrom.

If Buyer fails to comply with this section or if any injury or damage is caused, in whole or in part, by Buyer's failure to comply with applicable federal or state laws, rules or regulations safety requirements, Buyer shall indemnify and hold Seller harmless against any claims, loss or expense for injury or damage arising from the use of the goods and/or replacement parts.

### CMCO Warranty (HOISTS)

A. Columbus McKinnon Corporation ("Seller") warrants to the original end user ("Buyer") that, for a period of one (1) year from the date of Seller's delivery of the goods (collectively, the "Goods") to the carrier, the Goods will be free from defects in workmanship and materials. (b) for a period of three (3) years from the date of Seller's delivery of the Goods to the carrier, the brake discs on the Goods will be free from defects in workmanship and materials; and (c) for the life of the Goods, the mechanical components including, without limitation, the sidewinder hoist lever, of the Goods (other than the brake discs on the Goods) will be free from defects in workmanship and materials. . In addition, Seller warrants to Buyer that, for a period of one (1) year from the date of their delivery by Seller to the carrier, any aftermarket or replacement parts, accessories or components purchased by Buyer with respect to any Goods (collectively, "Replacement Parts") will be free from defects in workmanship and materials.

B. IN THE EVENT OF ANY BREACH OF ANY SUCH WARRANTY, SELLER'S SOLE OBLIGATION SHALL BE EXCLUSIVELY LIMITED TO, AT THE OPTION OF SELLER, REPAIR OR REPLACEMENT, F.O.B. SELLER'S POINT OF SHIPMENT, OF ANY GOODS OR REPLACEMENT PARTS THAT SELLER DETERMINES TO HAVE BEEN DEFECTIVE OR, IF SELLER DETERMINES THAT SUCH REPAIR OR REPLACEMENT IS NOT FEASIBLE, TO A REFUND OF THE PURCHASE PRICE UPON RETURN OF THE GOODS OR REPLACEMENT PARTS TO SELLER. NO CLAIM AGAINST SELLER FOR ANY BREACH OF (i) SUCH WARRANTY WITH RESPECT TO THE ELECTRICAL COMPONENTS OF ANY GOOD OR REPLACEMENT PARTS SHALL BE VALID OR ENFORCEABLE UNLESS BUYER'S WRITTEN NOTICE THEREOF IS RECEIVED BY SELLER WITHIN ONE (1) YEAR FROM THE DATE OF SELLER'S DELIVERY TO THE CARRIER, (ii) SUCH WARRANTY WITH RESPECT TO THE BRAKE DISCS OF ANY GOOD SHALL BE VALID OR ENFORCEABLE UNLESS BUYER'S WRITTEN NOTICE THEREOF IS RECEIVED BY SELLER WITHIN THREE (3) YEARS FROM THE DATE OF SELLER'S DELIVERY TO THE CARRIER AND (iii) SUCH WARRANTY WITH RESPECT TO THE MECHANICAL COMPONENTS, INCLUDING, WITHOUT LIMITATION, THE SIDEWINDER HOIST LEVER, OF ANY GOOD (OTHER THAN THE BRAKE DISCS ON ANY GOOD) SHALL BE VALID OR ENFORCEABLE UNLESS BUYER'S WRITTEN NOTICE THEREOF IS RECEIVED BY SELLER WITHIN ONE (1) YEAR FROM THE DATE ANY ALLEGED CLAIM ACCRUES. EXCEPT FOR THE WARRANTIES SET FORTH ABOVE, SELLER MAKES NO OTHER WARRANTIES WITH RESPECT TO THE GOODS OR ANY REPLACEMENT PARTS, WHETHER EXPRESSED OR IMPLIED, INCLUDING ANY WARRANTIES OF MERCHANTABILITY, FITNESS FOR A PARTICULAR PURPOSE, QUALITY AND/OR THOSE ARISING BY STATUTE OR OTHERWISE BY LAW OR FROM ANY COURSE OF DEALING OR USE OF TRADE, ALL OF WHICH ARE HEREBY EXPRESSLY DISCLAIMED.

C. IN NO EVENT SHALL SELLER BE LIABLE TO BUYER OR ANY THIRD PARTY WITH RESPECT TO ANY GOOD OR REPLACEMENT PART, WHETHER IN CONTRACT, TORT OR OTHER THEORY OF LAW, FOR LOSS OF PROFITS OR LOSS OF USE, OR FOR ANY INCIDENTAL, CONSEQUENTIAL, SPECIAL, DIRECT OR INDIRECT DAMAGES, HOWSOEVER CAUSED. SELLER'S MAXIMUM LIABILITY TO BUYER WITH RESPECT TO THE GOODS OR ANY REPLACEMENT PART SHALL IN NO EVENT EXCEED THE PRICE PAID BY BUYER FOR THE GOODS OR REPLACEMENT PART THAT ARE THE SUBJECT OF THE APPLICABLE CLAIM.

D. Seller shall not be liable for any damage, injury or loss arising out of the use of the Goods or any Replacement Part if, prior to such damage, injury or loss, such Goods or Replacement Parts are: (1) damaged or misused following Seller's delivery to the carrier; (2) not maintained, inspected, or used in compliance with applicable law and Seller's written instructions and recommendations; or (3) installed, repaired, altered or modified (a) with any part or accessory other than those supplied by Seller or (b) without compliance with such laws, instructions or recommendations.

E. This warranty is limited and provided only to the original end user. **Each Good and Replacement Part must be registered within sixty (60) days of receipt of each product to establish eligibility.** Please register at [www.cmworks.com/hoist-warranty-registration](http://www.cmworks.com/hoist-warranty-registration) or submit registration card via US mail.

F. Any action against Seller for breach of warranty, negligence or otherwise in connection with the electrical components of any Good must be commenced by Buyer within one (1) year after: (a) the date any alleged claim accrues; or (b) the date of delivery of the Goods to Buyer, whichever is earlier. Any action against Seller for breach of warranty, negligence or otherwise in connection with the brake discs on any Good must be commenced by Buyer within three (3) years after: (y) the date any alleged claim accrues; or (z) the date of delivery of the Goods to Buyer, whichever is earlier. Any action against Seller for breach of warranty, negligence or otherwise in connection with the mechanical components of any Good (other than the brake discs on any Good) must be commenced by Buyer within one (1) year after the date any alleged claim accrues. Any action against Seller for breach of warranty, negligence or otherwise in connection with any Replacement Part must be commenced by Buyer within one (1) year after: (y) the date any alleged claim accrues; or (z) the date of delivery of the Replacement Part to Buyer, whichever is earlier.

G. This warranty is contingent upon Buyer's proper maintenance and care of the Goods and/or Replacement Part, and does not extend to normal wear and tear. Seller reserves the right, at its option, to void this warranty in the event of Buyer's use with the Goods and/or Replacement Parts of parts or accessories other than those supplied by Seller.

### WARNING

Alterations or modifications of equipment and use of non-Seller replacement parts can lead to dangerous operation and injury.

#### TO AVOID INJURY:

- Do not alter or modify equipment.
- Do use only replacement parts manufactured by seller.



USA: Ph: (800) 888.0985 • (716) 689.5400 • Fax: (716) 689.5644 • [www.columbusmckinnon.com](http://www.columbusmckinnon.com)

CANADA: Ph: (877) 264.6478 • Fax: (877) 264.6477 • [www.columbusmckinnon.com](http://www.columbusmckinnon.com)

GERMANY: Ph: +49 7940 128-0 • Fax +49 7940 55665 • [www.stahlcranes.com](http://www.stahlcranes.com)

*Partners In Motion Control*

© 2021 Columbus McKinnon Corporation. All Rights Reserved.

**ULINE** H-9942

1-800-295-5510

1221 IH-9942VND