

ULINE H-8796, H-8797 FLAT FILE CABINET

1-800-295-5510
uline.com

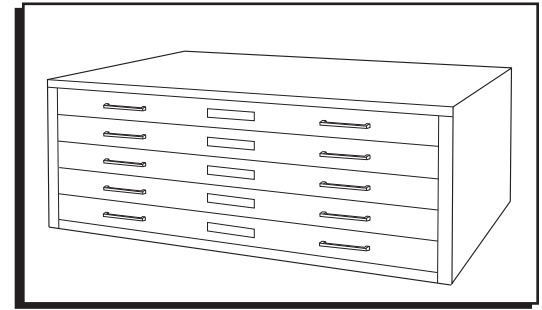

TOOLS NEEDED

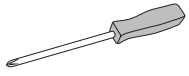

Phillips Screwdriver

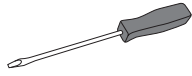

Flathead Screwdriver



10 mm Wrench



Rubber Mallet

PARTS



Handle x 10

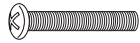

M6 x 55 mm Bolt x 2



M4 x 6 mm Handle Screw x 20



M4 Washer x 20



M6 Nut x 2

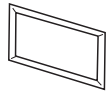

Label Holder x 5

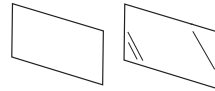

Paper Label and Plastic Cover x 5

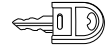

Key x 2

ASSEMBLY

HANDLES AND LABEL HOLDERS

1. Place handle on front of drawer and insert two M4 x 6 mm handle screws with two M4 washers through opposite side. Tighten using a Phillips screwdriver. Repeat for all drawers. (See Figure 1)

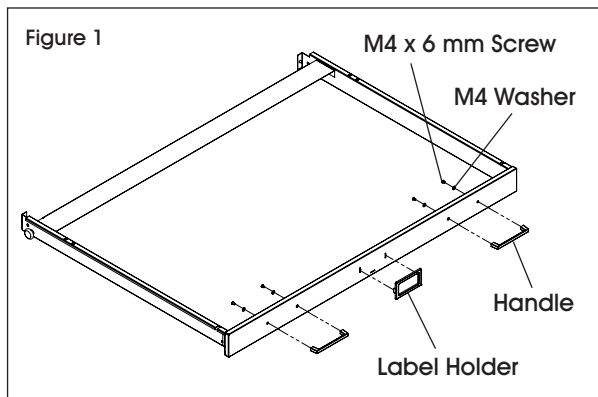

2. Attach label holders by pushing tabs through slots in front of drawer and bending tabs on back of drawer toward center to secure.

STACKING

1. Remove bottom drawer (A) of top unit and top drawer (B) of bottom unit. (See Figure 2)

 **NOTE:** To remove drawers, pull drawers straight out and lift up.

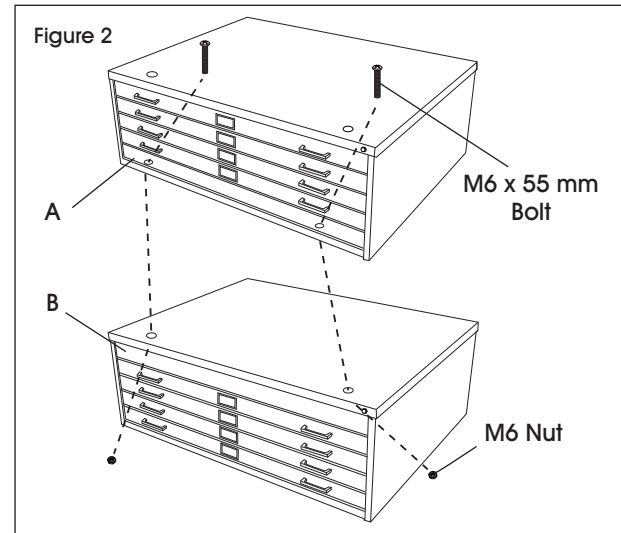

2. Remove knockout caps on top of bottom unit.

 **NOTE:** Knockout caps can be removed using a flathead screwdriver and rubber mallet. Stand the flathead screwdriver on the knockout caps and tap the top of the screwdriver handle with the rubber mallet to knock the caps off.

3. Stack units and align holes at front ledge of units. Insert M6 x 55 mm bolts into top and bottom unit. Attach M6 nuts and tighten to secure.

ULINE H-8796, H-8797

ARCHIVERO PLANO

800-295-5510

uline.mx

HERRAMIENTAS NECESARIAS



Desarmador de Cruz

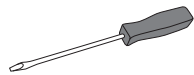

Desarmador Plano

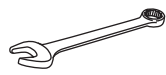

Llave de 10 mm



Mazo de Caucho

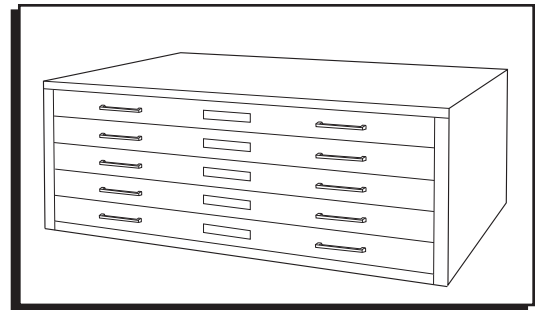

PARTES



10 Asas



2 Pernos M6 x 55 mm



20 Tornillos para Asa M4 x 6 mm



20 Rondanas M4



2 Tuercas M6

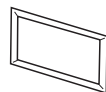

5 Portaetiquetas

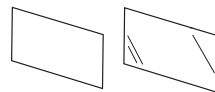

5 Etiquetas de Papel y Cubiertas de Plástico

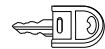

2 Llaves

ENSAMBLE

ASAS Y PORTAETIQUETAS

1. Coloque el asa al frente del cajón e inserte en el lado opuesto dos tornillos para asa M4 x 6 mm con dos rondanas M4. Apriete utilizando un desarmador de cruz. Repita la operación para todos los cajones. (Vea Diagrama 1)

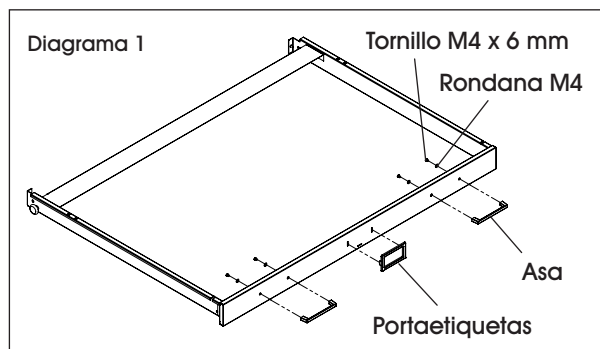

2. Fije los portaetiquetas empujando la pestaña en las ranuras al frente del cajón y doblando las pestañas en la parte posterior del cajón hacia el centro para asegurarlas.

ESTIBAR

1. Retire el cajón inferior (A) de la unidad superior y el cajón superior (B) de la unidad inferior. (Vea Diagrama 2)

 **NOTA:** Para quitar los cajones, jale hacia afuera y levántelos.

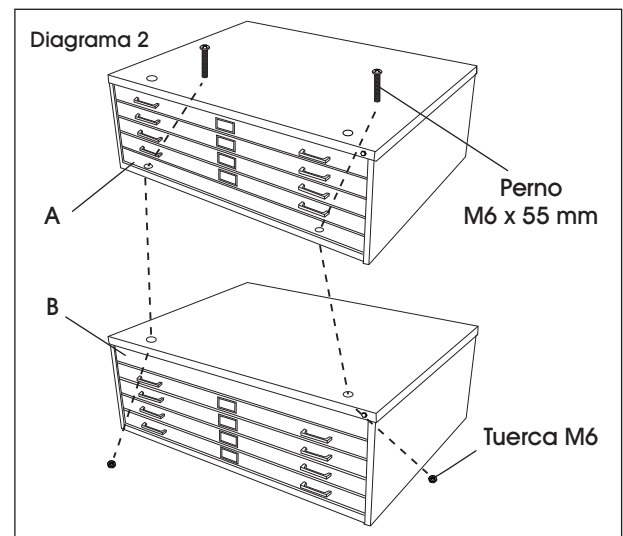

2. Retire los tapones que están en la parte superior de la unidad inferior.

 **NOTA:** Puede quitar los tapones utilizando un desarmador de cabeza plana y mazo de caucho. Coloque el desarmador de cabeza plana en los tapones y golpee la parte superior del mango del desarmador con el mazo de caucho para sacar los tapones

3. Estibe las unidades y alinee los orificios al borde frontal de las unidades. Inserte los pernos M6 x 55 mm en la parte superior e inferior de la unidad. Fije las tuercas M6 y apriete para asegurar.

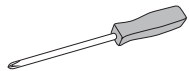
OUTILS REQUIS

Tournevis cruciforme

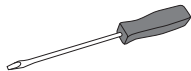

Tournevis à tête plate



Clé de 10 mm

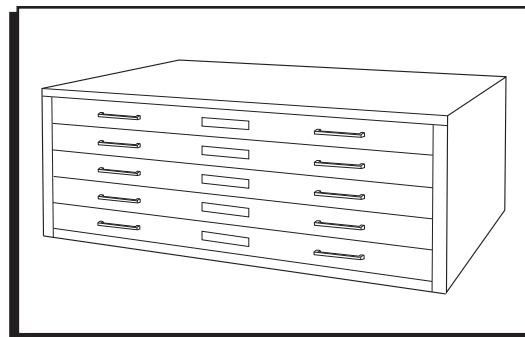
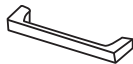

Maillet en caoutchouc

**PIÈCES**

Poignée x 10



Boulon M6 x 55 mm x 2



Vis de poignée M4 x 6 mm x 20



Rondelle M4 x 20



Écrou M6 x 2

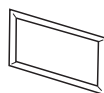

Porte-étiquette x 5

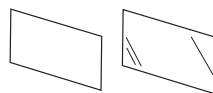

Étiquette en papier et protection en plastique x 5



Clé x 2

ASSEMBLAGE**POIGNÉES ET PORTE-ÉTIQUETTES**

- Placez la poignée sur le devant du tiroir et insérez deux vis de poignée M4 x 6 mm avec deux rondelles M4 du côté opposé. Serrez le tout en vous servant d'un tournevis cruciforme. Répétez pour tous les tiroirs. (Voir Figure 1)

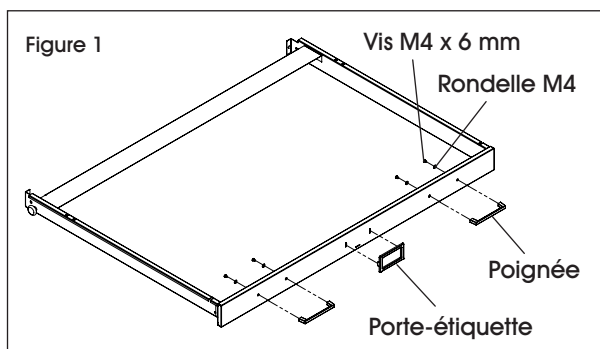

- Fixez les porte-étiquettes en poussant les languettes dans les fentes à l'avant du tiroir et en pliant les languettes à l'arrière vers le centre.

EMPILAGE

- Retirez le tiroir inférieur (A) de l'unité supérieure et le tiroir supérieur (B) de l'unité inférieure. (Voir Figure 2)



REMARQUE : Pour retirer les tiroirs, tirez-les tout droit et soulevez-les.

Figure 2

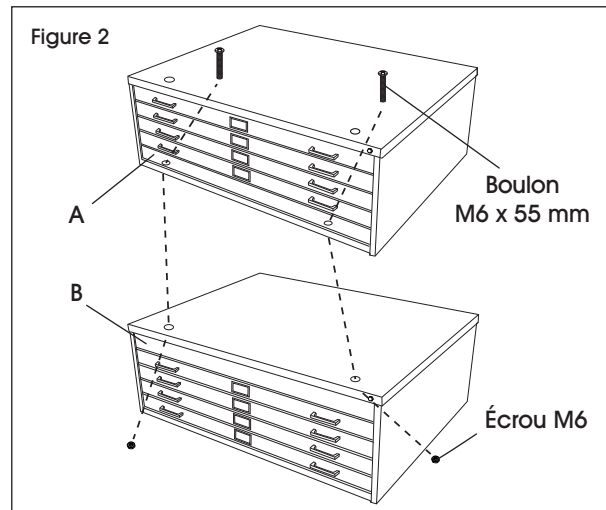

- Enlevez les capuchons de protection sur le dessus de l'unité inférieure.



REMARQUE : Les capuchons de protection peuvent être retirés à l'aide d'un tournevis à tête plate et d'un maillet en caoutchouc. Placez le tournevis à tête plate sur les capuchons de protection et tapez sur le dessus du manche du tournevis avec le maillet en caoutchouc pour faire tomber les capuchons.

- Empilez les unités et alignez les trous sur le rebord avant des unités. Insérez les boulons M6 x 55 mm dans les unités supérieure et inférieure. Fixez les écrous M6 et serrez le tout.