

# ULINE H-8082 INDUSTRIAL ELECTRIC PRESSURE WASHER

1-800-295-5510  
uline.com

### TOOLS NEEDED

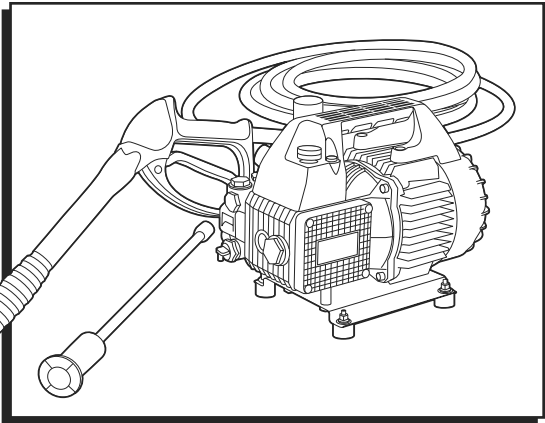

## QUICK ASSEMBLY GUIDE



**IMPORTANT!** Please read carefully:

- Using extension cords is not recommended. If one must be used, cords 50' or less should be 12 gauge.
- Cords longer than 50' should be 10 gauge.

2. Replace with yellow vented oil cap found in accessory bag. (See Figure 2)

### VENTED OIL CAP

1. Remove red unvented shipping cap as shown. (See Figure 1)

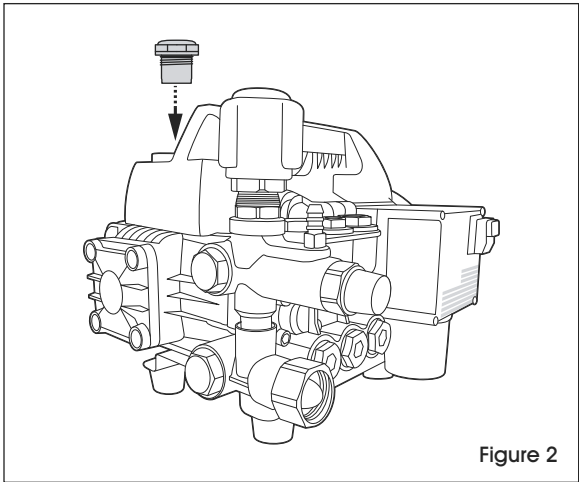
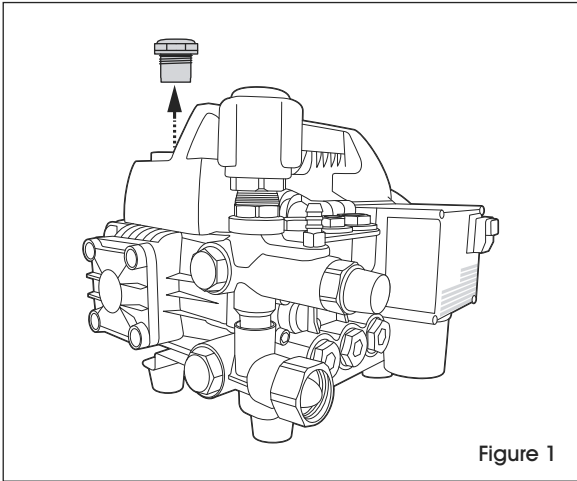

## QUICK ASSEMBLY GUIDE CONTINUED

### QUICK CONNECT

1. Remove red cap from outlet as shown. (See Figure 3)

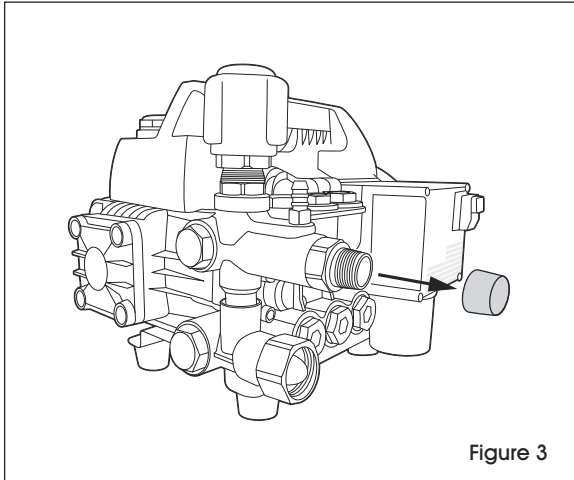

2. Screw on quick connect found in accessory bag. Tighten with 1" wrench. (See Figure 4)

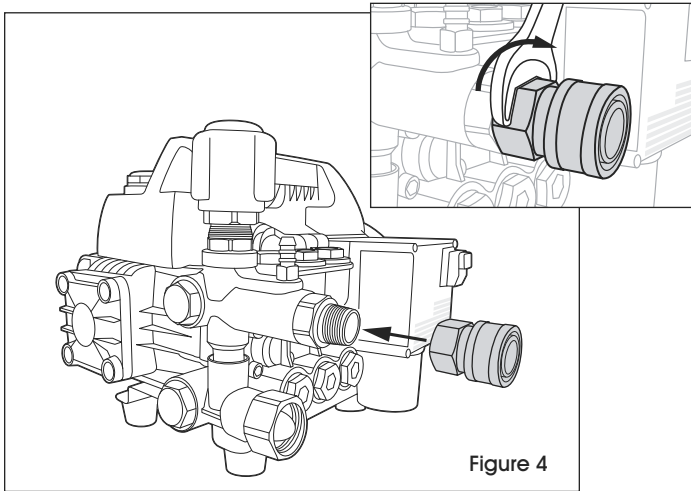

### GUN/HOSE ASSEMBLY

1. Screw gun and hose threads together by hand – turning clockwise until hand-tight. Hose threads already have pipe-sealing tape applied to them. (See Figure 5)

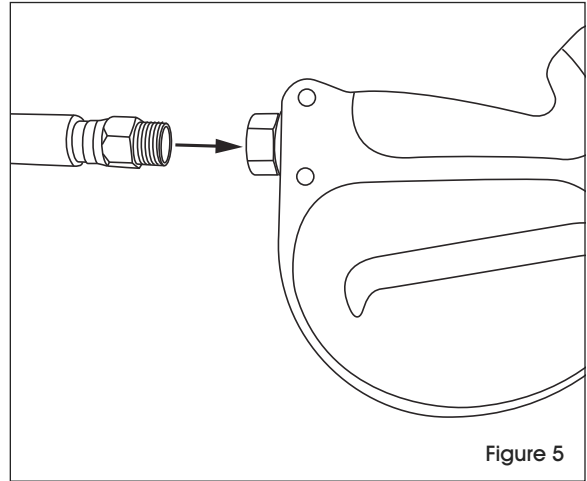

2. Use 3/4" wrench on the hose fitting. Use a 7/8" wrench on the gun fitting. Tighten clockwise until snug. (See Figure 6)
3. Gun/Hose assembly is ready for use.

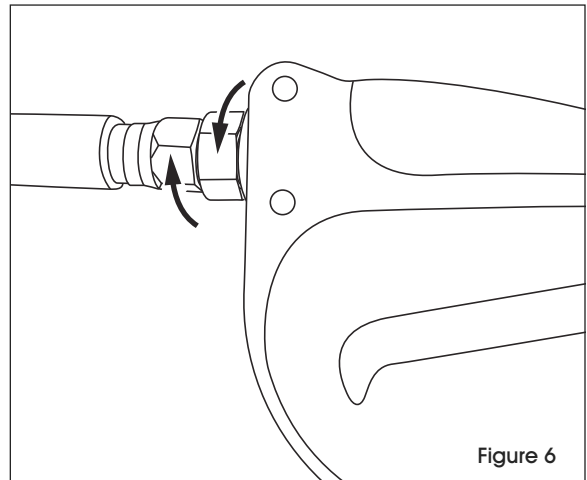

**ULINE**

1-800-295-5510

uline.com

# ULINE H-8082

## LIMPIADOR A PRESIÓN ELÉCTRICO INDUSTRIAL

800-295-5510  
uline.mx

### HERRAMIENTAS NECESARIAS

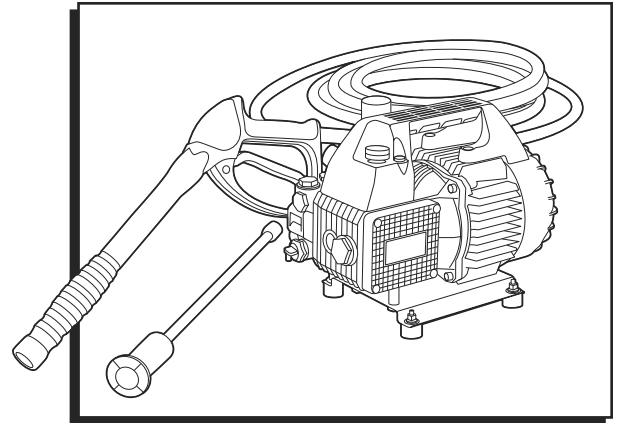
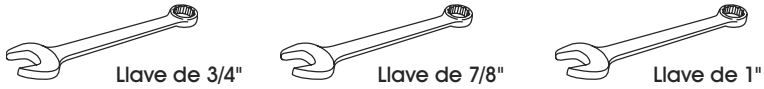

## GUÍA RÁPIDA DE ENSAMBLE



**¡¡IMPORTANTE!** Lea atentamente:

- No se recomienda usar extensiones eléctricas. Si se necesita usar una, debe ser de calibre 12 si mide 50' o menos.
- Si mide más de 50' debe ser de calibre 10.

### TAPA DE ACEITE VENTILADA

1. Retire la tapa roja sin ventilación para envíos como se muestra. (Vea Diagrama 1)

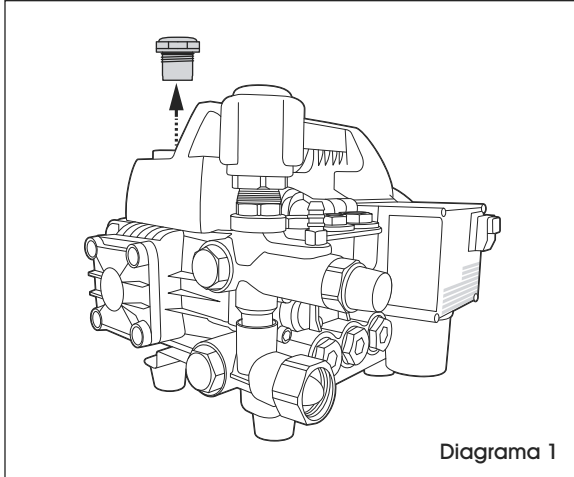

2. Reemplace con la tapa de aceite amarilla ventilada que podrá encontrar en la bolsa de accesorios. (Vea Diagrama 2)

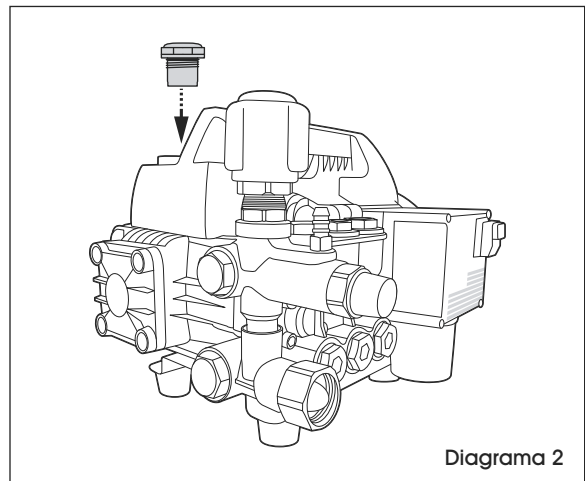

# CONTINUACIÓN DE GUÍA RÁPIDA DE ENSAMBLE

## CONEXIÓN RÁPIDA

1. Retire la capa roja de la salida como se muestra. (Vea Diagrama 3)

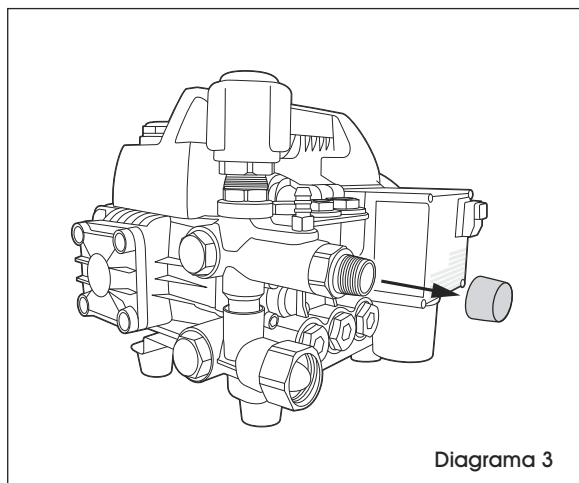

2. Enrosque la conexión rápida que podrá encontrar en la bolsa de accesorios. Apriete con la llave de 1". (Vea Diagrama 4)

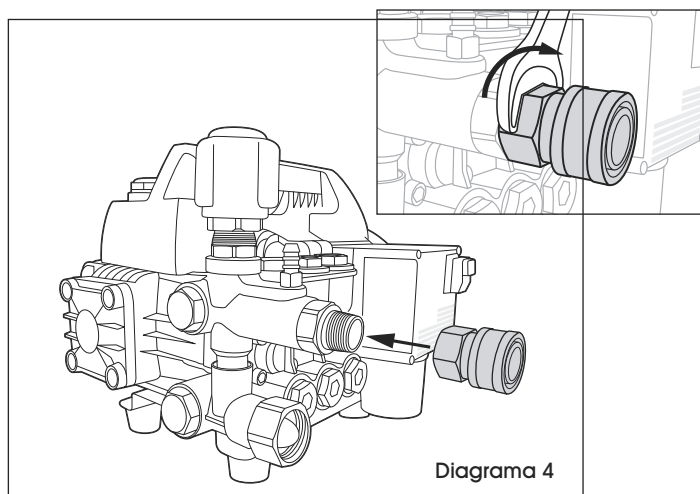

## ENSAMBLE DE PISTOLA/MANGUERA

3. Enrosque la pistola a la manguera utilizando sus manos girando en el sentido de las manecillas del reloj hasta que apriete bien. Las roscas de la manguera ya cuentan con cinta de teflón en ellas. (Vea Diagrama 5)

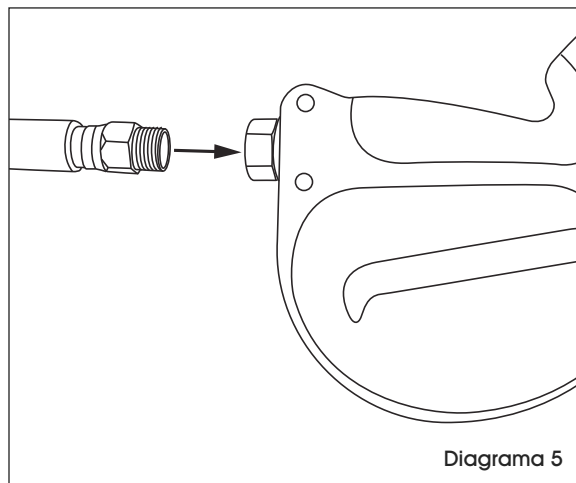

4. Utilice la llave de 3/4" en el acople de la manguera. Utilice la llave de 7/8" en el acople de la pistola. Apriete en el sentido de las manecillas del reloj hasta que quede ajustado. (Vea Diagrama 6)
5. El ensamble de la pistola/manguera está listo para usarse.

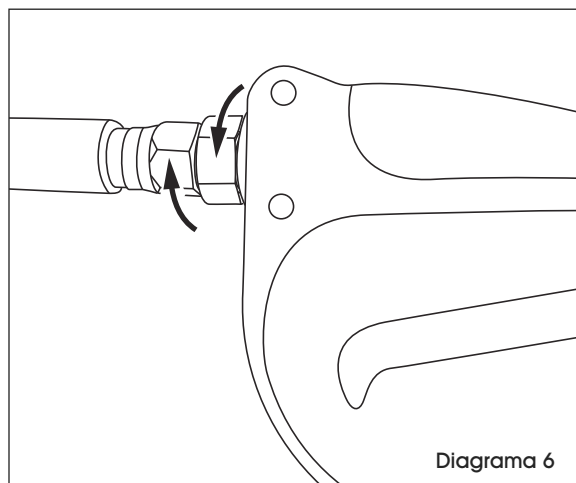

**ULINE**

800-295-5510

uline.mx

**ULINE H-8082**

# NETTOYEUR À PRESSION ÉLECTRIQUE INDUSTRIEL

1-800-295-5510

uline.ca

## OUTILS REQUIS



Clé de 3/4 po

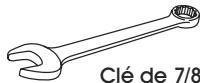

Clé de 7/8 po

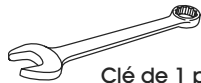

Clé de 1 po

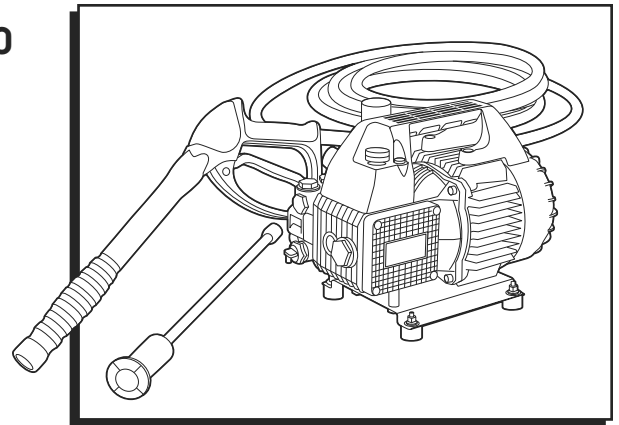

## GUIDE DE MONTAGE RAPIDE



**IMPORTANT!** Veuillez lire attentivement :

- L'utilisation de rallonges électriques n'est pas recommandée. Si l'utilisation de rallonges est absolument nécessaire, celles d'une longueur de 50 pieds ou moins doivent être de calibre 12.
- Celles d'une longueur supérieure à 50 pieds doivent être de calibre 10.

### BOUCHON D'HUILE VENTILÉ

1. Enlevez le bouchon d'expédition rouge comme indiqué. (Voir Figure 1)

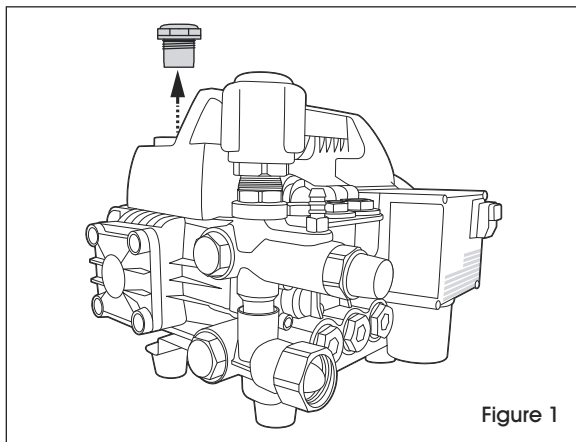

Figure 1

2. Remplacez-le avec le bouchon d'huile ventilé jaune qui se trouve dans le sac d'accessoires. (Voir Figure 2)

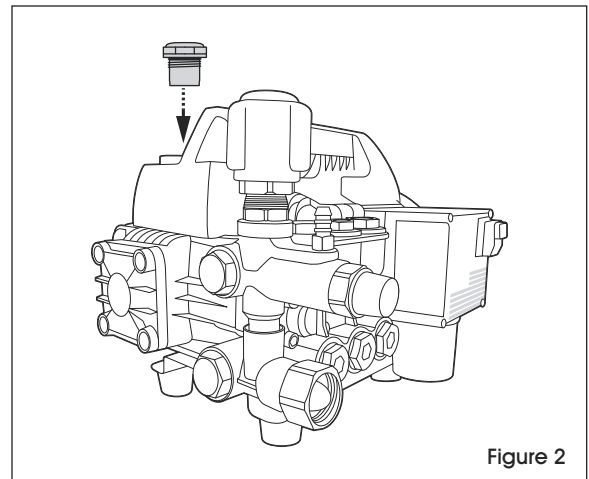

Figure 2

# GUIDE DE MONTAGE RAPIDE SUITE

## CONNEXION RAPIDE

1. Enlevez le bouchon rouge du raccord du tuyau comme indiqué. (Voir Figure 3)

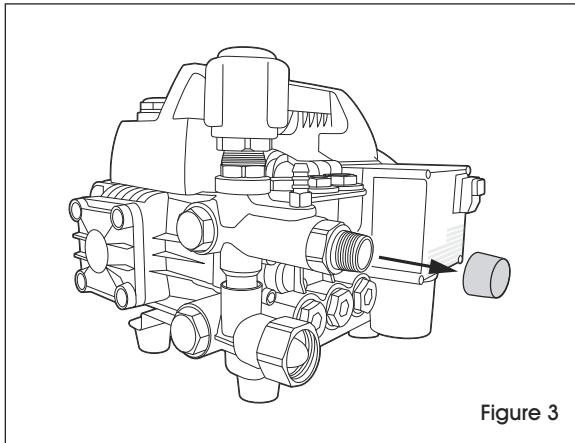

Figure 3

2. Vissez le dispositif de connexion rapide qui se trouve dans le sac d'accessoires. Serrez avec la clé de 1 po. (Voir Figure 4)

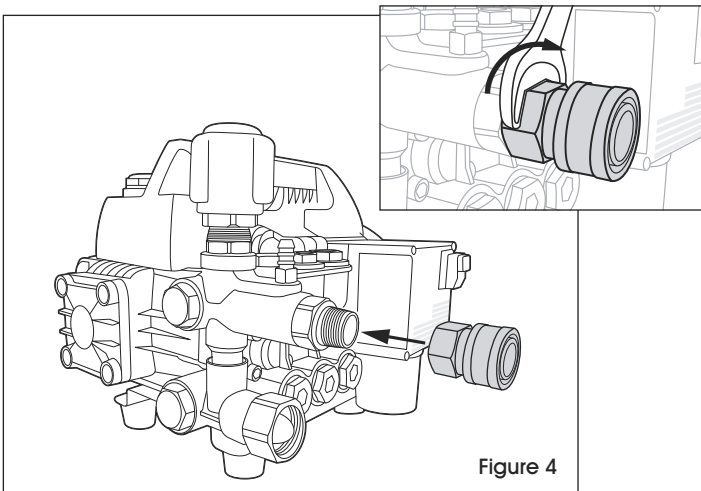

Figure 4

## ASSEMBLAGE PISTOLET/TUYAU

3. Raccordez le pistolet et le tuyau à la main – tournez dans le sens horaire jusqu'à ce qu'ils soient serrés. Le filetage du tuyau est déjà doté d'un ruban d'étanchéité. (Voir Figure 5)

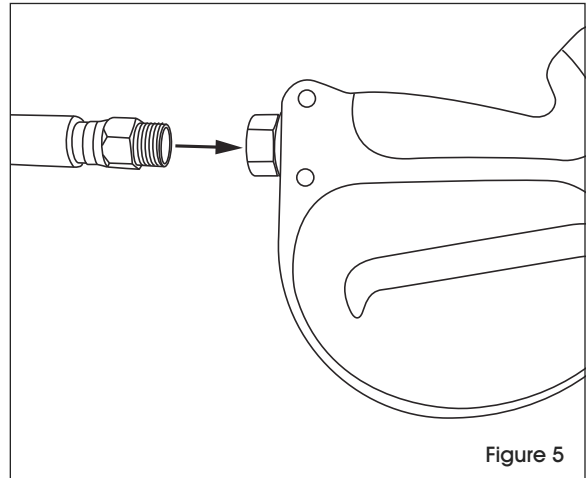

Figure 5

4. Utilisez la clé de 3/4 po sur le bout du tuyau et celle de 7/8 po sur celui du pistolet. Serrez dans le sens horaire jusqu'à ce qu'ils s'entre-bloquent. (Voir Figure 6)
5. L'assemblage pistolet/tuyau est prêt à l'emploi.

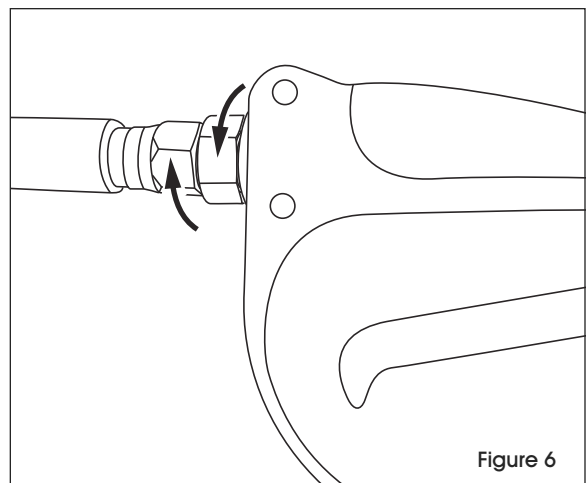

Figure 6

**ULINE**

1-800-295-5510

uline.ca