



Before using the tool,
read the operating
instructions carefully.



OR 4000.13

Combination tool for plastic strapping

 **ORGAPACK**

1 Technical data

Weight	2.3 kg (5 lbs)
Strap Tension	Depending on breaking strength of strap
Sealing	With seal
Seals	ORP2100.13

Plastic Strap

Strap quality	Polypropylene (PP) Polyester (PET)
Strap width	12–13 mm (1/2)
Thickness	0.4–0.7 mm (.015"–.027")

2 Safety instructions

This tool was designed and manufactured for safe handling during the strapping operation.

1. Before using the tool read the operating instructions carefully.
2. When operating the tool, wear eye, face, and hand protection (cutting protected gloves).
3. Do not put hands or other parts of the body between the strap and the package.
4. When cutting the strap, hold the upper portion and stand a safe distance away from the strap.
Caution: The lower strap will snap forward.
5. Do not stand in line with the strap while it is tensioned. The strap could break!
6. Only use original ORGAPACK seals.
7. Only use original ORGAPACK spare parts.



1.



2.



3.



4.

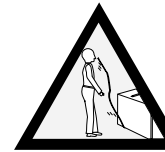

5.



6.



7.

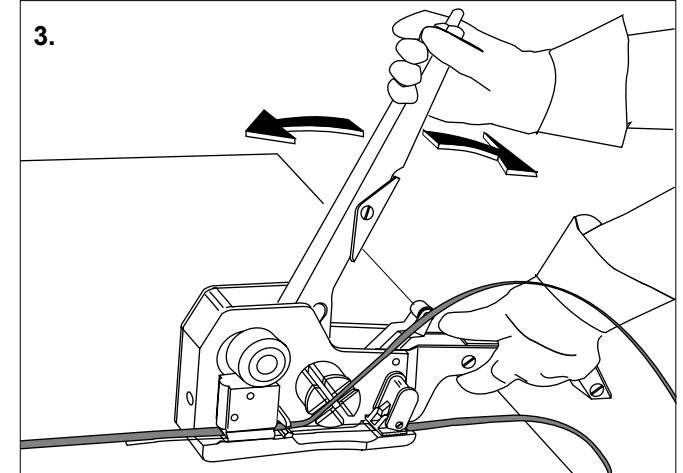
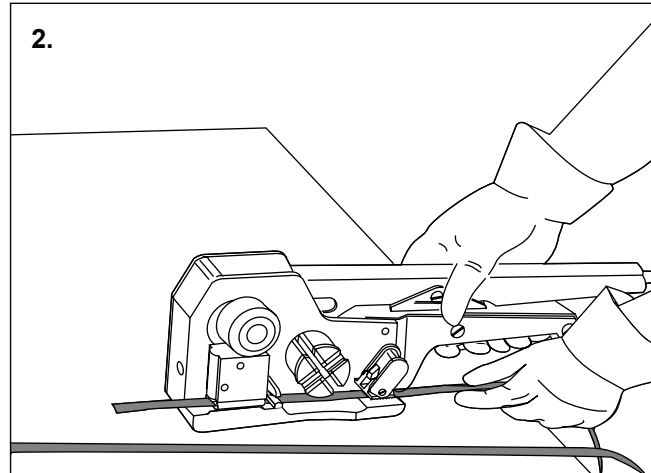
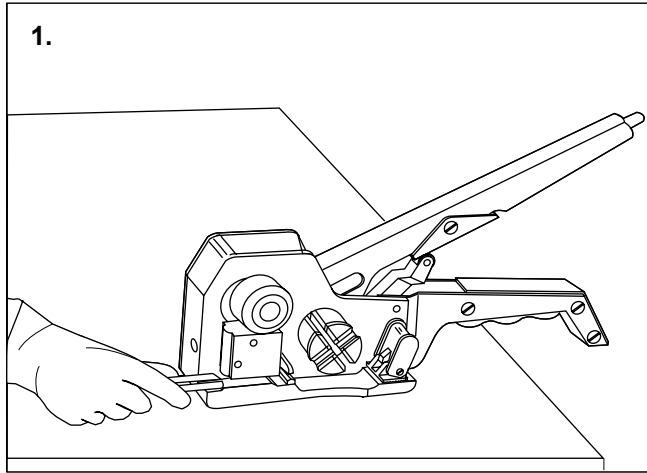

3 Operating

Fig. 1

- Slide seal from the front into the tool up to the stop with the opening of the seal facing outwards.

Fig. 2

- Place the strap around the package.
- Press lever down to the stop. Insert strap into seal, under cutter and clamp plate. Release lever.

Fig. 3

- Pull strap from dispenser and lead around package. Insert strap into seal, cutter and windlass.
- Move the lever backwards and forwards until desired strap tension is reached.

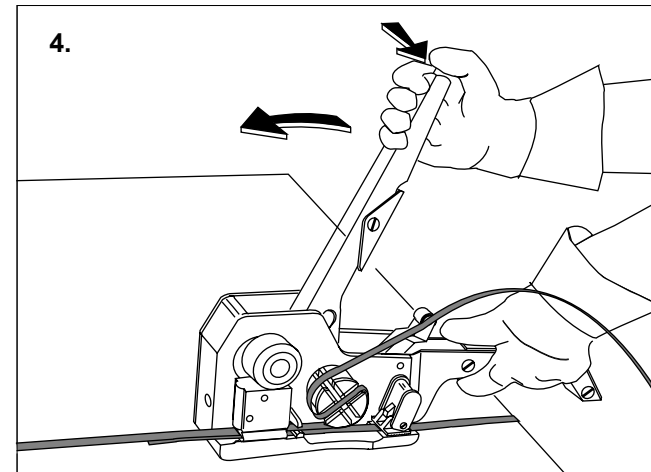

Fig. 4

- Press button at the rear of the lever. Do not hold button.
- Use a little force (approx. 35 lbs./150 N) to move lever backwards and forwards until seal is completely closed. More force cannot obtain a better closing but it can damage the tool.

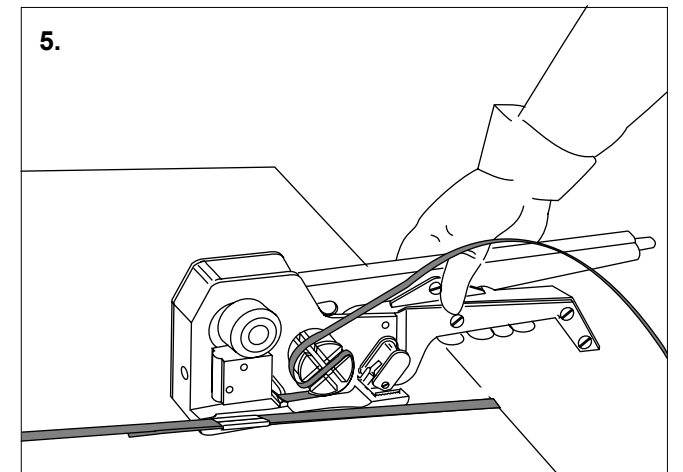

Fig. 5

- Press lever down to the stop. Do not hold button at the rear of lever. Turn tool away from the seal.

Maintenance note

Periodically lubricate all moving parts with one or two drops of light machine oil.