

ULINE H-7670

VINYL PADDED MOBILE SHOP STOOL

1-800-295-5510
uline.com

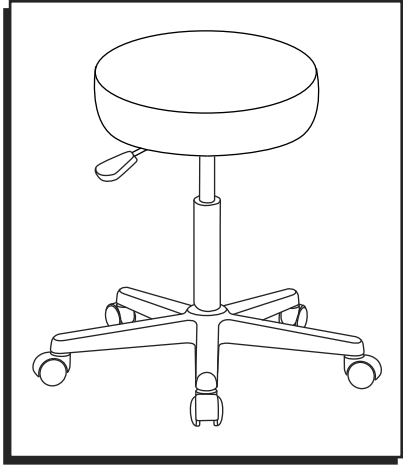

TOOL INCLUDED



Allen Wrench

PARTS LIST

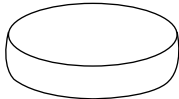

Seat Cushion x 1

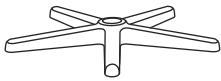

5-Star Base x 1



Caster x 5

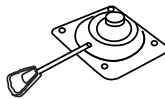

Mechanism x 1



Gas Lift x 1



Bolt x 4

ASSEMBLY

1. Insert casters into legs of five-star base. Turn base upright. Insert gas lift into center of base. (See Figure 1)

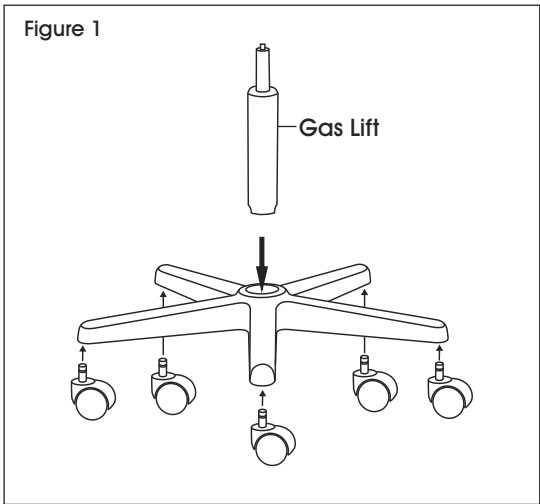

2. Align mechanism with holes on bottom of seat cushion. Use four bolts to secure. (See Figure 2)

 **NOTE:** Use Allen wrench to tighten bolts.

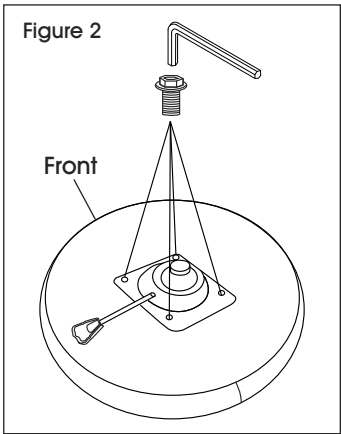

3. Slowly lower seat assembly onto the gas lift. Press down on seat cushion to secure. (See Figure 3)

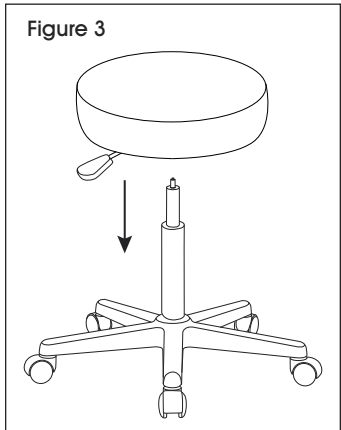

STOOL ADJUSTMENT

1. Seat Height Adjustment – To raise seat height, lift lever up with little to no weight on the seat. To lower seat height, lift lever up while sitting.

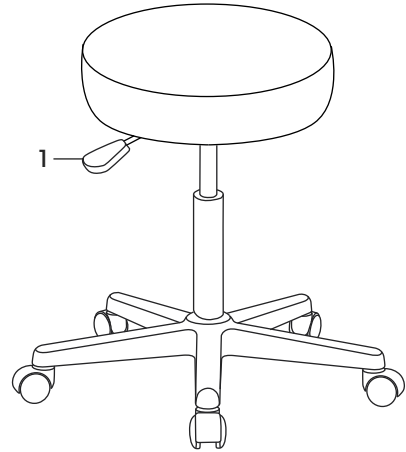

ULINE H-7670

BANCO MÓVIL ACOJINADO DE VINIL PARA TALLER

800-295-5510
uline.mx

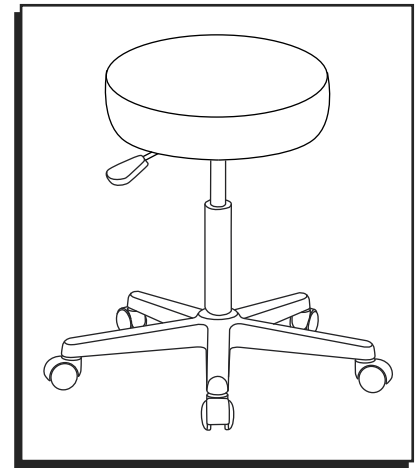

HERRAMIENTA INCLUIDA



Llave Allen

LISTA DE PARTES

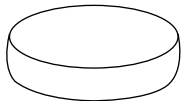

1 Asiento
Acojinado

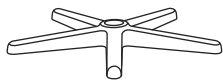

1 Base Estrella



5 Ruedas

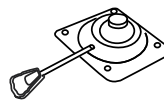

1 Mecanismo



1 Pistón de Gas



4 Pernos

INSTRUCCIONES DE ENSAMBLE

1. Inserte las ruedas en las patas de la base estrella. Enderece la base. Inserte el pistón de gas en el centro de la base. (Vea Diagrama 1)

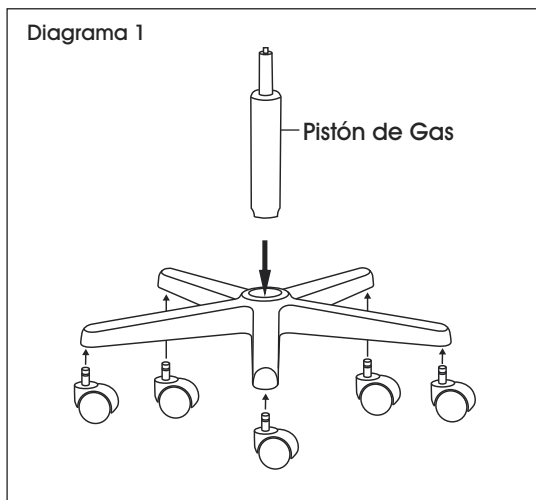

2. Alinee el mecanismo con los orificios en la parte inferior del asiento acojinado. Use cuatro pernos para fijarlos. (Vea Diagrama 2)

 **NOTA: Utilice la llave Allen para apretar todos los pernos.**

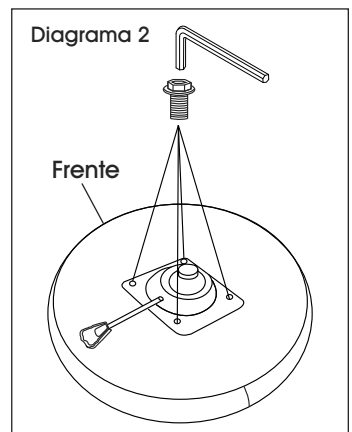

3. Baje lentamente el ensamble del asiento por encima del pistón de gas. Presione el asiento acojinado para asegurarlo. (Vea Diagrama 3)

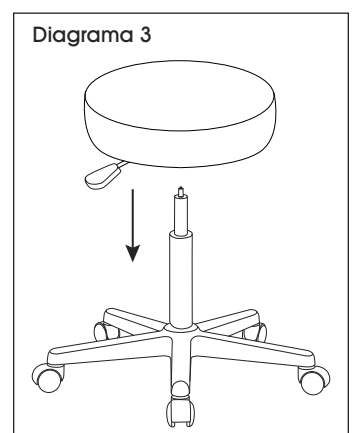

AJUSTE DEL BANCO

1. Ajuste de la Altura del Asiento – Para aumentar la altura del asiento, levante la palanca sin o con poco peso en el asiento. Para bajar la altura del asiento, levante la palanca mientras está sentado.

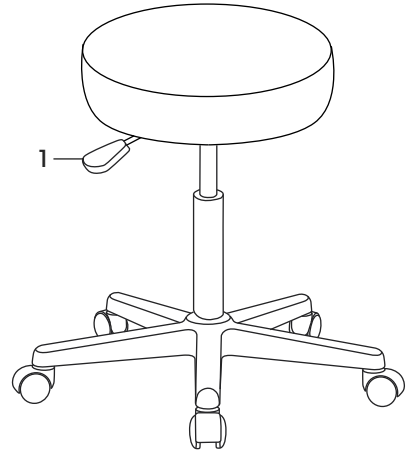

ULINE H-7670

TABOURET D'ATELIER MOBILE REMBOURRÉ EN VINYLE

1-800-295-5510
uline.ca

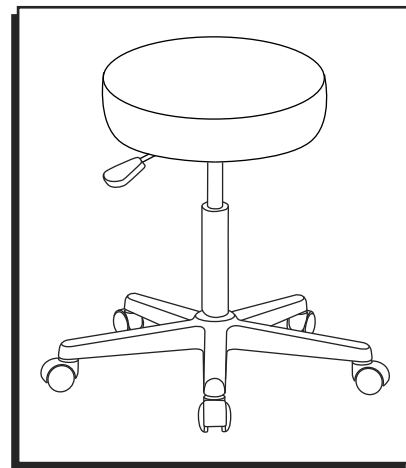

OUTIL INCLUS



Clé Allen

LISTE DES PIÈCES

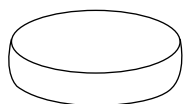

Coussin de siège x 1



Base à cinq branches x 1



Roulette x 5

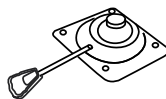

Mécanisme x 1



Vérin
pneumatique x 1



Boulon x 4

INSTRUCTIONS DE MONTAGE

1. Insérez les roulettes dans les pieds de la base à cinq branches. Retournez la base à l'endroit. Insérez le vérin pneumatique dans le centre de la base. (Voir Figure 1)

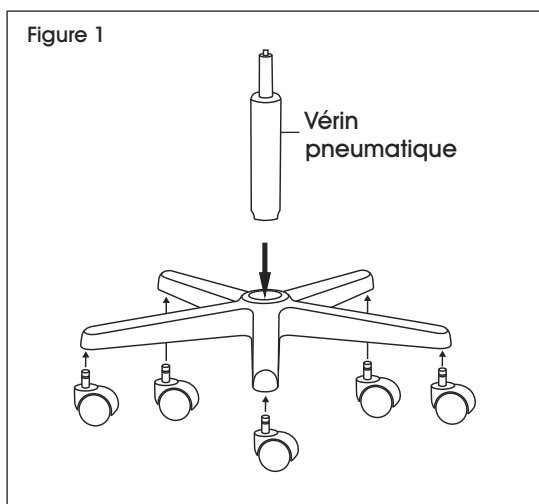

2. Alignez le mécanisme sur les trous situés au bas du siège. Utilisez quatre boulons pour le fixer en place. (Voir Figure 2)



REMARQUE :
Utilisez une clé Allen pour serrer les boulons.

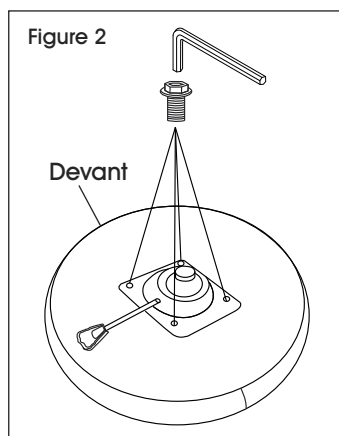

3. Abaissez lentement l'ensemble du siège sur le vérin pneumatique. Appuyez sur le siège pour le fixer. (Voir Figure 3)

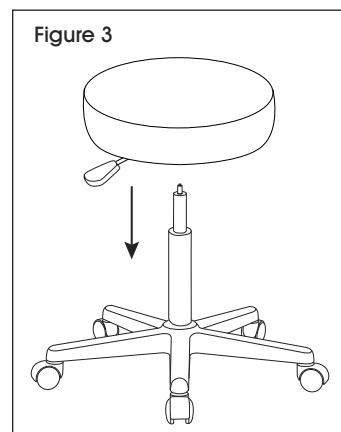

RÉGLAGE DU TABOURET

1. Réglage de la hauteur du siège – Pour élever la hauteur du siège, soulevez le levier avec peu ou sans poids sur le siège. Pour abaisser la hauteur du siège, soulevez le levier en position assise.

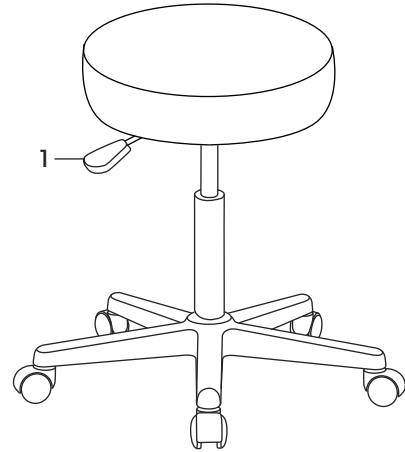

ULINE

1-800-295-5510
uline.ca