

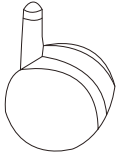

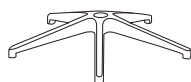



PARTS LIST					
1	Caster x 5	2	5-Star Base x 1	3	Gas Lift x 1
					
4	Mechanism x 1	5	Seat Cushion x 1	6	Back Cushion x 1
					
7	Armrest x 2	8	Screw x 6 1/4 x 1 1/2"	9	Screw x 4 1/4 x 1 1/4"
					
10	Screw x 3 5/16 x 7/8"	11	Washer x 6	Allen Wrench x 1	
					

ASSEMBLY INSTRUCTIONS		
<p>Step 1</p>	<p>Step 2</p>	<p>Step 3</p>
<p>Step 4</p>	<p>Step 5</p>	

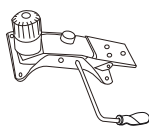
## CHAIR ADJUSTMENTS

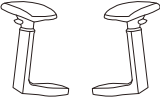
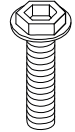
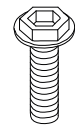

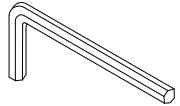
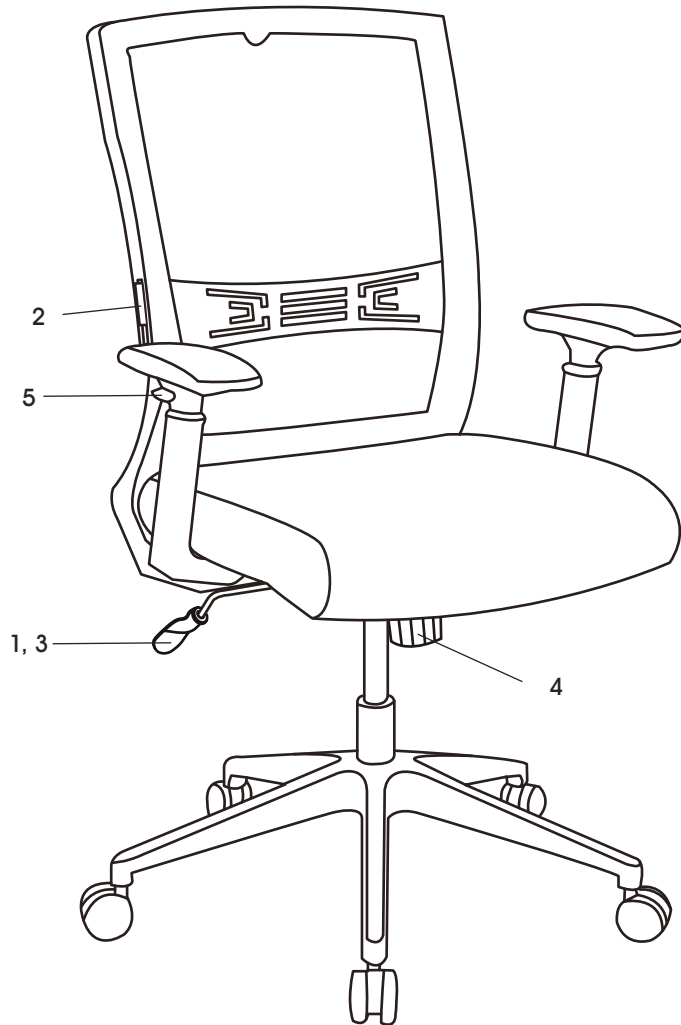
1. Seat Height Adjustment – To raise seat height, lift lever up with little to no weight on the seat. To lower seat height, lift lever up while sitting.
2. Adjustable Lumbar Support – To adjust lumbar support, lift support bar up and down to desired height using both hands.
3. Upright Tilt Lock – To lock the chair in an upright position, push the lever in toward the center of the seat. To restore tilt, pull lever out. Chair has synchro-tilt; the back tilts at a two-to-one ratio to the seat angle.
4. Tilt Tension – To increase tilt tension, turn knob clockwise. To decrease tilt tension, turn knob counterclockwise.
5. Adjustable Armrests (Height) – To adjust arm height, press the button on the side of each armrest and move the arm up and down.

# ULINE H-7628

## SILLA DE MALLA DOWNTOWN

800-295-5510  
uline.mx

### LISTA DE PARTES

1	5 Ruedas	2	1 Base Estrella	3	1 Pistón de Gas
4	1 Mecanismo	5	1 Asiento	6	1 Respaldo
7	2 Descansabrazos	8	6 Tornillos 1/4 x 1 1/2"	9	4 Tornillos 1/4 x 1 1/4"
10	3 Tornillos 5/16 x 7/8"	11	6 Rondanas		1 Llave Allen

### INSTRUCCIONES DE ENSAMBLE

<p>Paso 1</p>	<p>Paso 2</p>	<p>Paso 3</p>
<p>Paso 4</p>	<p>Paso 5</p>	

## AJUSTES DE LA SILLA

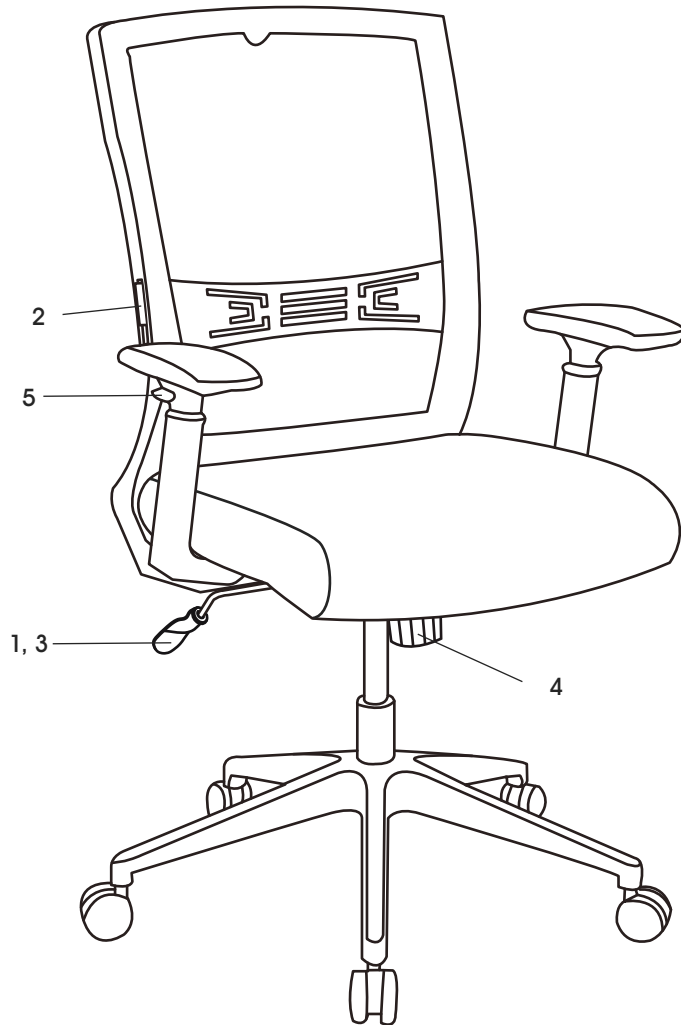







1. Ajuste de la Altura del Asiento – Para aumentar la altura del asiento, levante la palanca con poco o sin peso en el asiento. Para disminuir la altura del asiento, levante la palanca mientras esté sentado.
2. Soporte Lumbar Ajustable – Para ajustar el soporte lumbar, levante y baje la barra de soporte a la altura deseada usando ambas manos.
3. Bloqueo de la Inclinación del Poste – Para bloquear la silla en una posición vertical, empuje la palanca hacia el centro del asiento. Para restaurar la inclinación, jale la palanca. La silla cuenta con inclinación sincronizada; el respaldo se inclina en una proporción de dos a uno con respecto al ángulo del asiento.
4. Tensión de Inclinación – Para incrementar la tensión de la inclinación, gire la perilla en sentido de las manecillas del reloj. Para disminuir la tensión de inclinación, gire la perilla en sentido contrario a las manecillas del reloj.
5. Descansabrazos Ajustables (Altura) – Para ajustar la altura del descansabrazos, presione el botón que está en los laterales de cada descansabrazos y mueva cada uno hacia arriba y abajo.

# ULINE H-7628

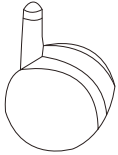
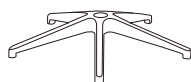

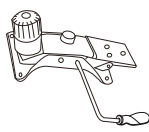
## DOWNTOWN – CHAISE EN MAILLE

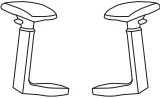
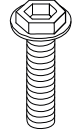
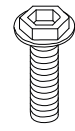
1-800-295-5510  
uline.ca

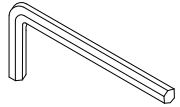
### LISTE DES PIÈCES

1	Roulette x 5	2	Base à 5 branches x 1	3	Vérin pneumatique x 1
					
4	Mécanisme x 1	5	Siège x 1	6	Dossier x 1
					
7	Accoudoir x 2	8	Vis x 6 1/4 x 1 1/2 po	9	Vis x 4 1/4 x 1 1/4 po
					
10	Vis x 3 5/16 x 7/8 po	11	Rondelle x 6	Clé Allen x 1	
					

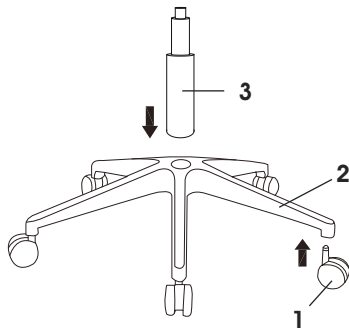
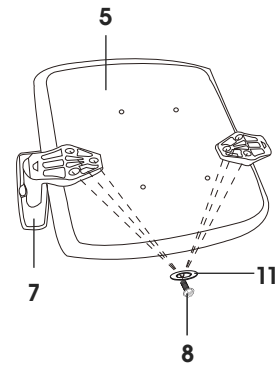
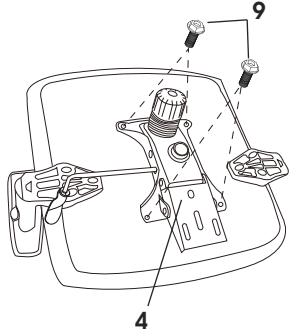
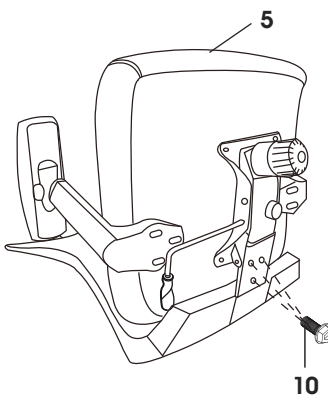
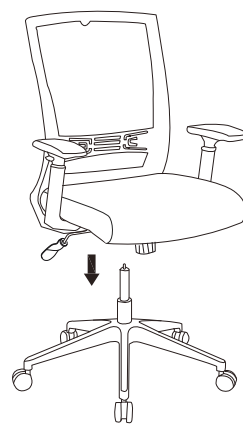
### INSTRUCTIONS DE MONTAGE

<p>Étape 1</p> 	<p>Étape 2</p> 	<p>Étape 3</p> 
<p>Étape 4</p> 	<p>Étape 5</p> 	

## RÉGLAGES DE LA CHAISE

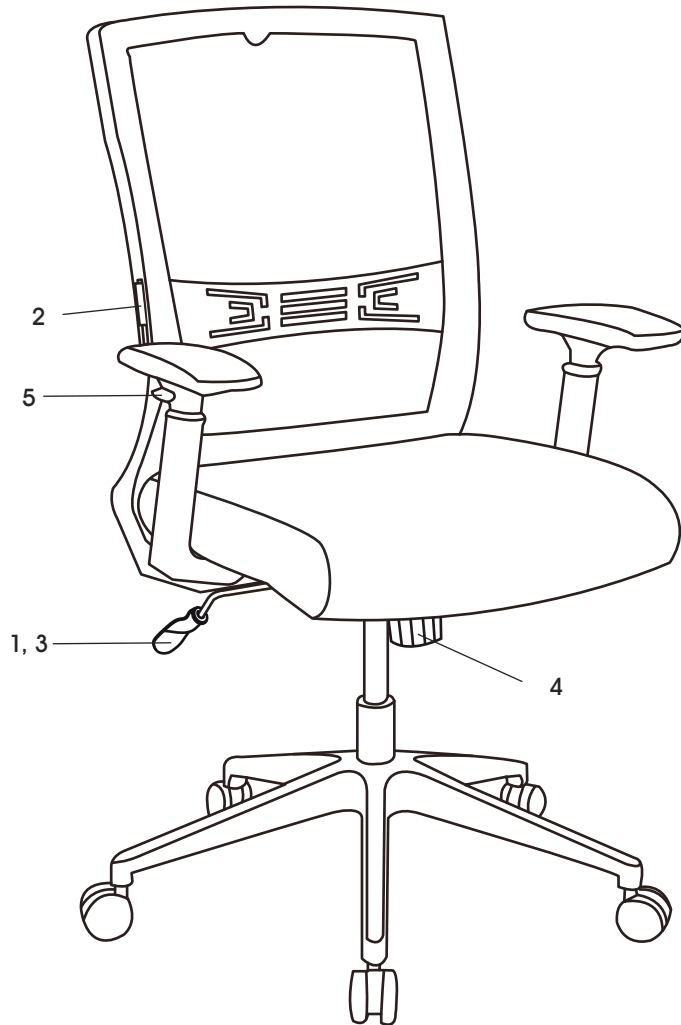

1. Réglage de la hauteur du siège – Pour élever la hauteur du siège, soulevez le levier avec peu ou sans poids sur le siège. Pour abaisser la hauteur du siège, soulevez le levier en position assise.
2. Soutien lombaire ajustable – Pour ajuster le support lombaire, soulevez et abaissez des deux mains la barre du support à la hauteur voulue.
3. Inclinaison avec blocage en position verticale – Pour bloquer la chaise en position verticale, poussez le levier vers le centre du siège. Pour rétablir l'inclinaison, tirez le levier vers l'extérieur. La chaise comporte une inclinaison synchrone; l'angle d'inclinaison du dossier est de deux pour un par rapport à l'angle du siège.
4. Tension d'inclinaison – Pour augmenter la tension d'inclinaison, tournez la molette dans le sens horaire. Pour diminuer la tension d'inclinaison, tournez la molette dans le sens antihoraire.
5. Accoudoirs ajustables (hauteur) – Pour régler les accoudoirs en hauteur, appuyez sur le bouton situé sur le côté de chacun des accoudoirs, puis faites bouger ceux-ci de haut en bas.