

ULINE H-7206 LD3500 AUTOMATIC LABEL DISPENSER

1-800-295-5510
uline.com

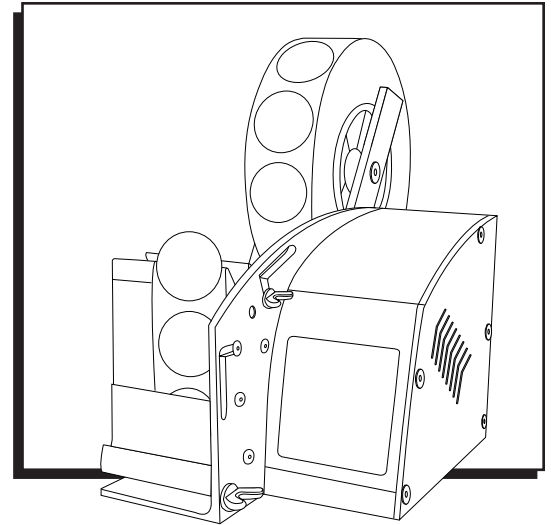

MAINTENANCE

1. Turn machine off when not in use.
2. Remove liner material from take-up hub when it reaches approximately 2" in diameter or if the motor appears to be straining.
3. Do not operate if inspection reveals a damaged power or sensor cord.
4. Keep strip plate, hold-down and hub free of adhesive buildup.

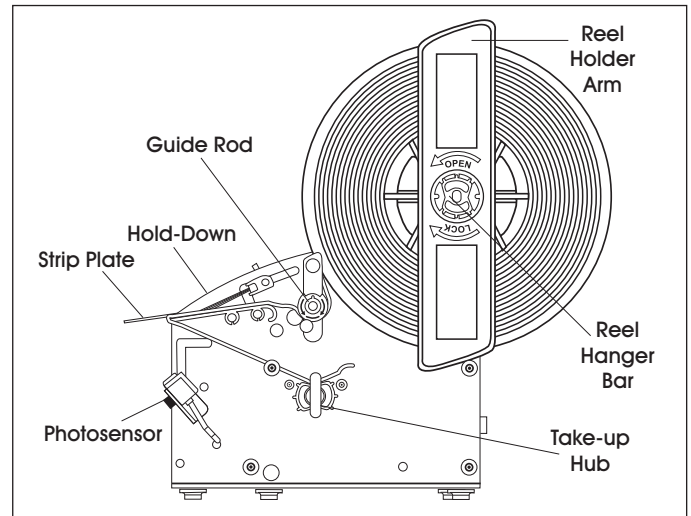

INSTRUCTIONS

Figure 1

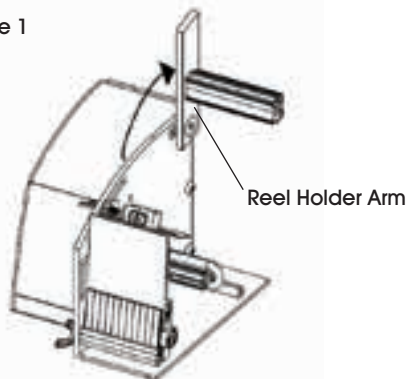

NOTE: Machine must be unplugged from power supply for steps 1 to 7.

1. Lift reel holder arm at 90° angle and lock into position using provided hex wrench. (See Figure 1)

INSTRUCTIONS CONTINUED

Figure 2

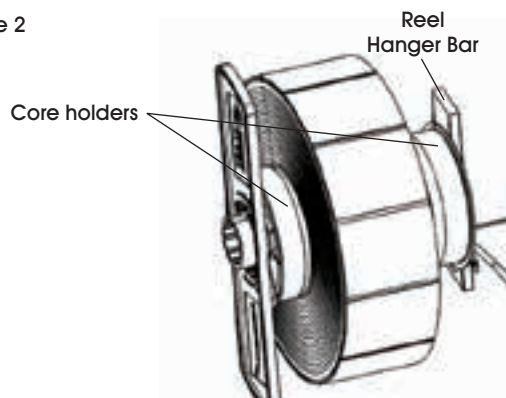

2. Insert core holders into each side of label roll.
3. Slide loaded roll into reel hanger bar. (See Figure 2)

 **NOTE:** Labels should dispense from under the roll.

Figure 3

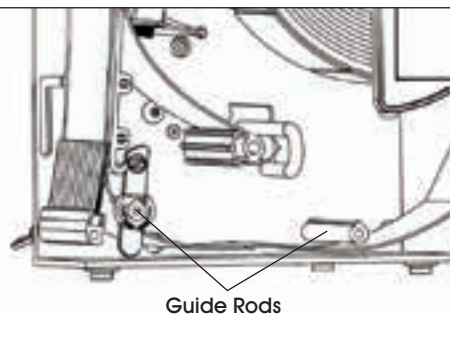

4. Feed label liner under guide rods. (See Figure 3)

Figure 4

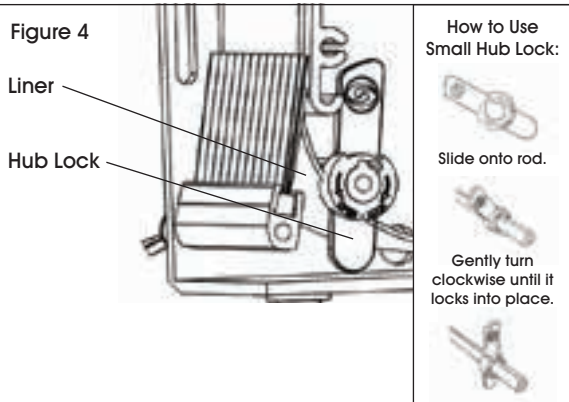

5. Feed label liner between brush and strip plate. (See Figure 4)
6. Adjust hub lock for guiding material.

Figure 5

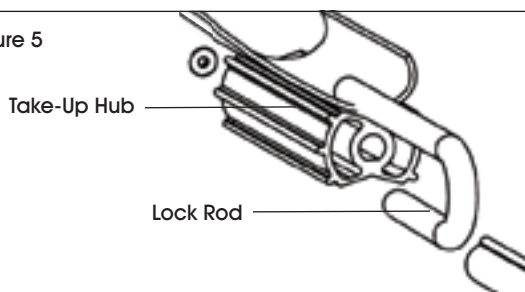

7. Slide lock rod off take-up hub. (See Figure 5)
8. Secure label liner onto take-up hub.

ADJUSTMENTS

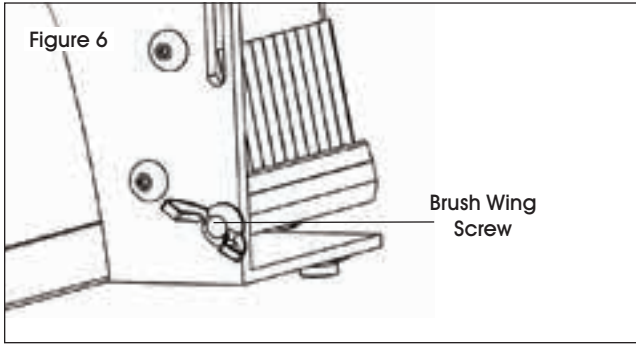

1. To apply the proper amount of tension for proper label feeding and detection, loosen brush wing screw and press down to increase tension, then tighten screw. (See Figure 6)

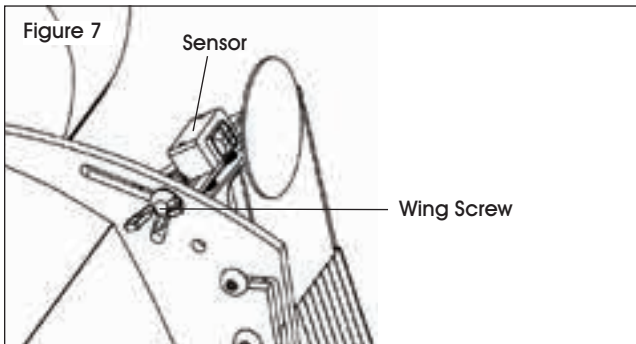

2. Loosen wing screw, then adjust sensor plate.
3. Point sensor toward the top edge of the label; then, tighten wing screw to secure sensor in place. (See Figures 7 and 8)

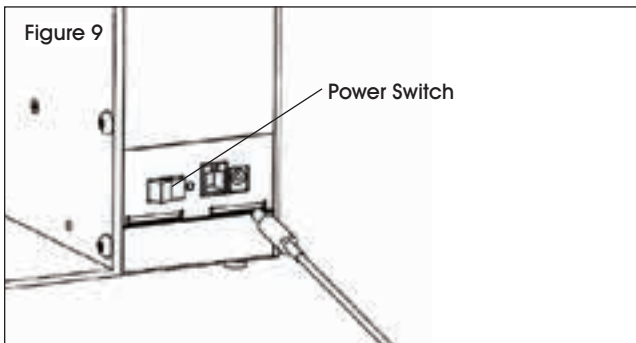
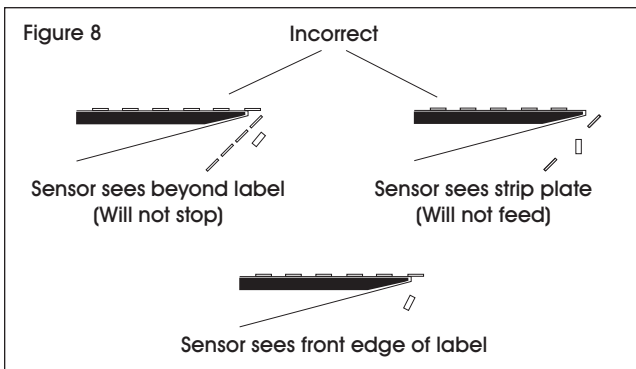

4. Connect power cord and press power switch to turn on. (See Figure 9)

ULINE H-7206

DESPACHADOR AUTOMÁTICO LD3500 DE ETIQUETAS ADHESIVAS

800-295-5510

uline.mx

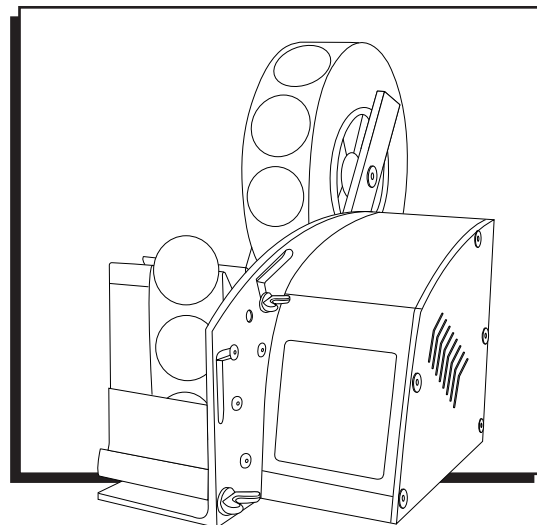

MANTENIMIENTO

1. Apague la máquina cuando no la esté utilizando.
2. Retire el material del respaldo del buje del inicio cuando alcance aproximadamente 2" del diámetro o si parece que el motor se está forzando.
3. No la use si la revisión revela que hay un cable eléctrico o sensor dañados.
4. Mantenga la placa de la tira presionada y el buje libre de acumulación de adhesivo.

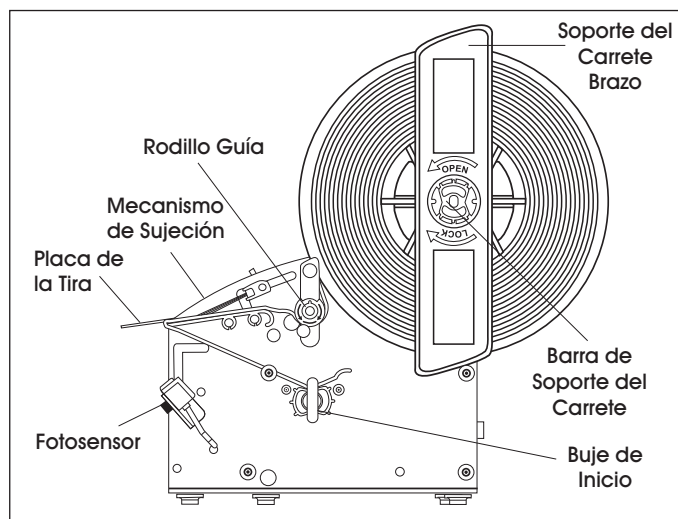

INSTRUCCIONES

Diagrama 1

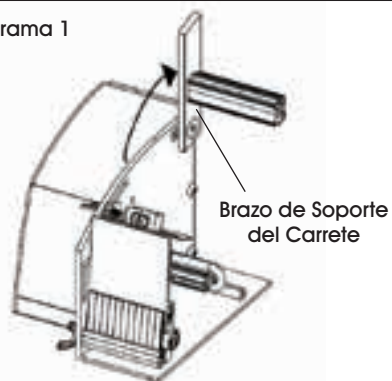

NOTA: Debe desconectar la máquina de la corriente eléctrica para los pasos 1 a 7.

1. Levante el brazo de soporte del carrete a un ángulo de 90° y asegúrelo en su lugar utilizando la llave hexagonal incluida. (Vea Diagrama 1)

CONTINUACIÓN DE INSTRUCCIONES

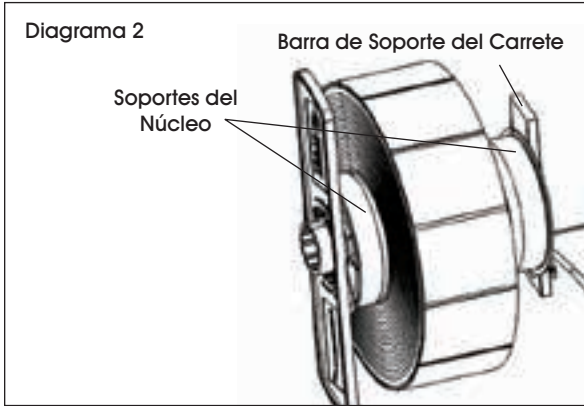

2. Inserte los soportes del núcleo en cada lado del rollo de etiquetas.
3. Deslice el rollo dentro de la barra de soporte del carrete. (Vea Diagrama 2)

 **NOTA:** Las etiquetas deben despacharse por debajo del rollo.

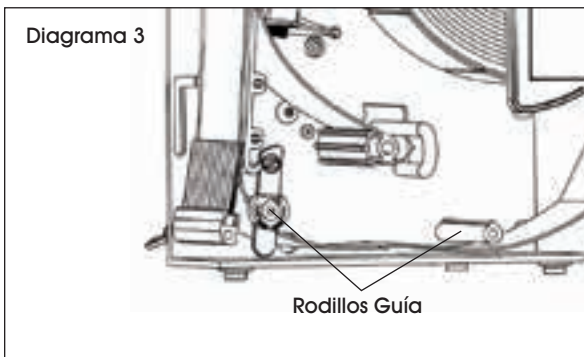

4. Ingrese el respaldo de las etiquetas por debajo de los rodillos de guía. (Vea Diagrama 3)

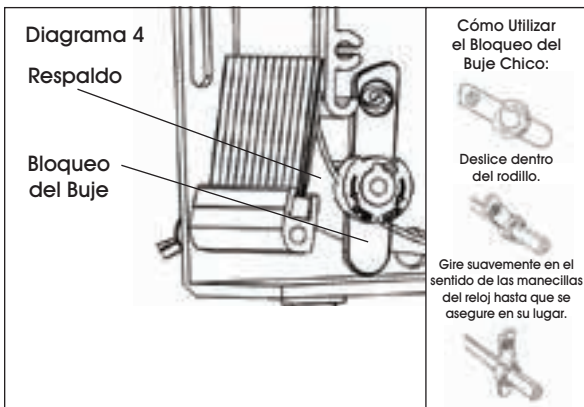

5. Ingrese el respaldo de las etiquetas entre el cepillo y la placa de la tira. (Vea Diagrama 4)
6. Ajuste el bloqueo del buje para guiar el material.

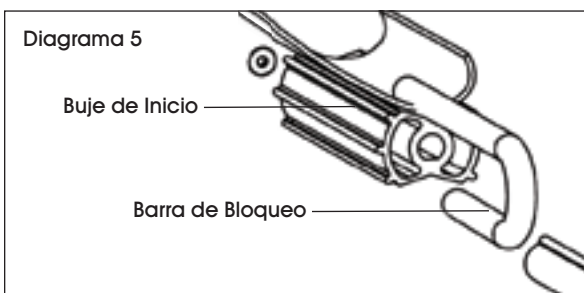

7. Deslice el rodillo de bloqueo hacia afuera del buje de inicio. (Vea Diagrama 5)
8. Asegure el respaldo de las etiquetas dentro del buje de inicio.

AJUSTES

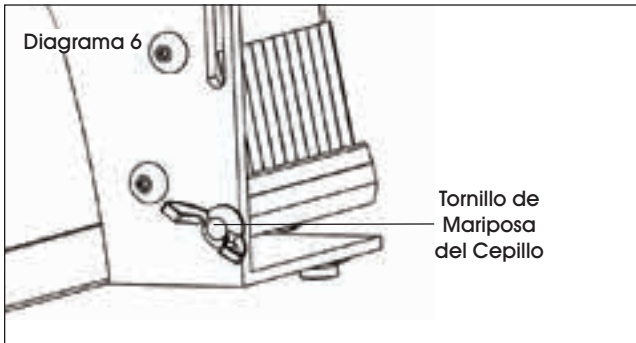

1. Para aplicar la cantidad de tensión adecuada para ingresar y detectar las etiquetas, afloje el tornillo de mariposa del cepillo y presione para aumentar la tensión, luego apriete el tornillo. (Vea Diagrama 6)

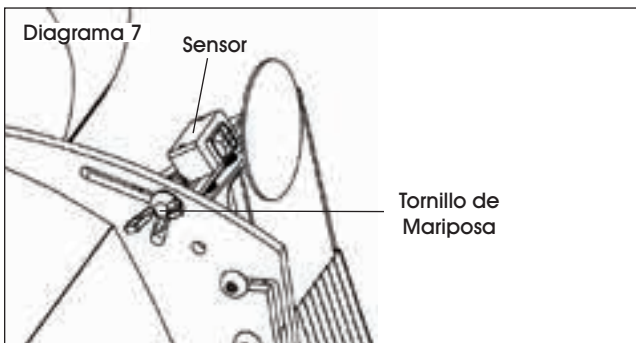

2. Afloje el tornillo de mariposa, luego ajuste la placa del sensor.
3. Apunte el sensor hacia la parte superior del borde de la etiqueta; luego apriete el tornillo de mariposa para asegurar el sensor en su lugar. (Vea Diagramas 7 y 8)

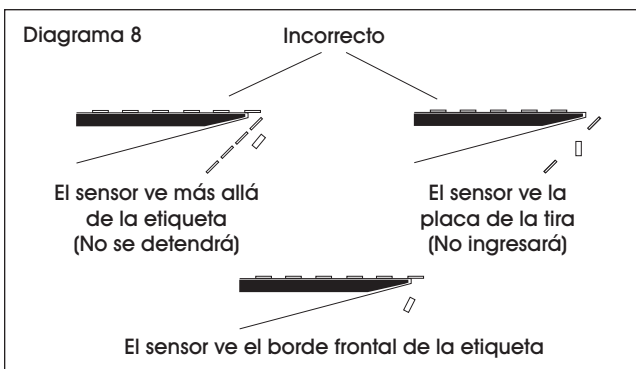

4. Conecte el cable y presione el interruptor de corriente para encenderlo. (Vea Diagrama 9)

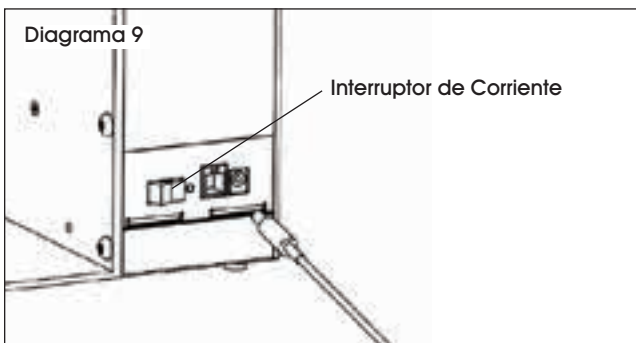

ULINE H-7206

LD3500 – DISTRIBUTEUR D'ÉTIQUETTES ADHÉSIVES AUTOMATIQUE

1-800-295-5510
uline.ca

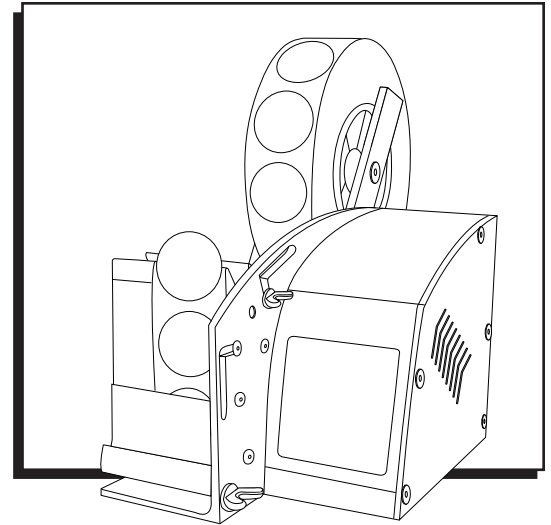

ENTRETIEN

1. Éteignez la machine lorsqu'elle n'est pas en cours d'utilisation.
2. Retirez le matériau de dorsal du moyeu d'alimentation lorsque le rouleau atteint un diamètre d'environ 2 po ou si le moteur semble peiner.
3. N'utilisez pas si vous observez pendant l'inspection un cordon d'alimentation ou un câble de capteur endommagé.
4. Maintenez la plaque de distribution, le dispositif de retenue et le moyeu dénués de résidus de colle.

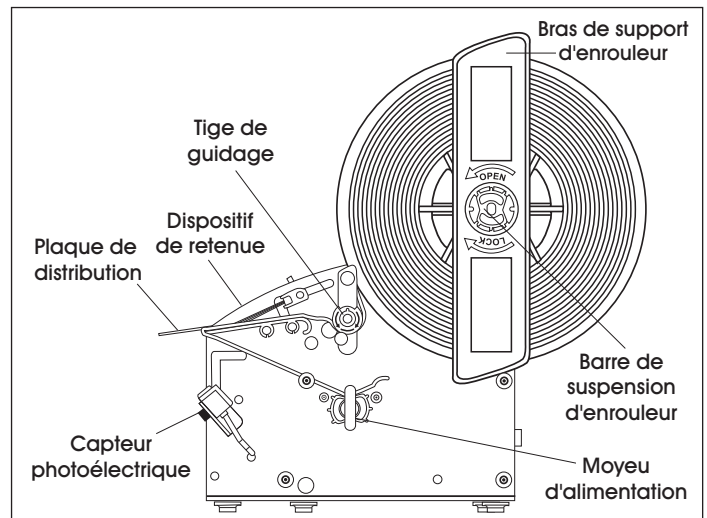

INSTRUCTIONS

Figure 1

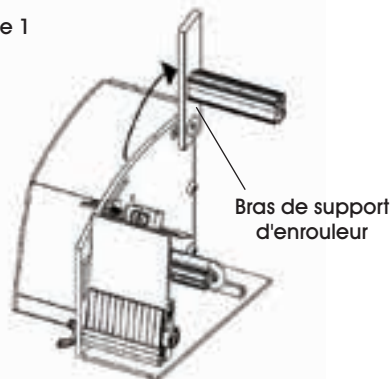

REMARQUE : La machine doit être débranchée de la source d'alimentation pendant l'exécution des étapes 1 à 7.

1. Levez le bras de support d'enrouleur à 90°, puis bloquez-le en position en utilisant la clé Allen fournie. (Voir Figure 1)

INSTRUCTIONS SUITE

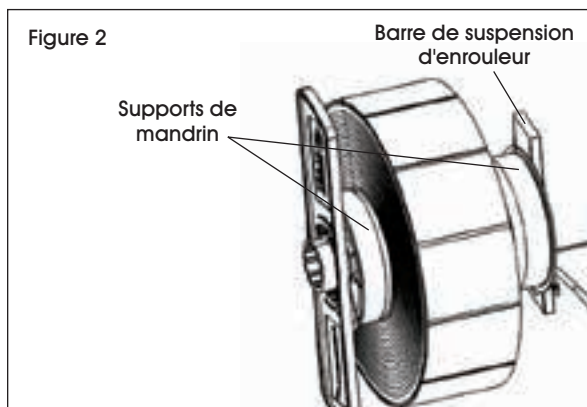

2. Insérez les supports de mandrin de chaque côté du rouleau d'étiquettes.
3. Faites glisser le rouleau ainsi chargé sur la barre de suspension d'enrouleur. (Voir Figure 2)

 **REMARQUE :** Les étiquettes doivent être dispensées par le bas du rouleau.

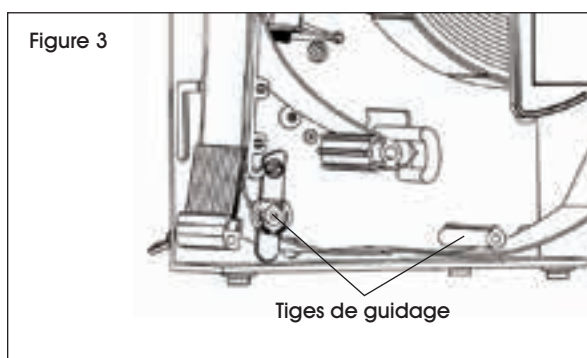

4. Faites passer le dorsal d'étiquettes sous les tiges de guidage. (Voir Figure 3)

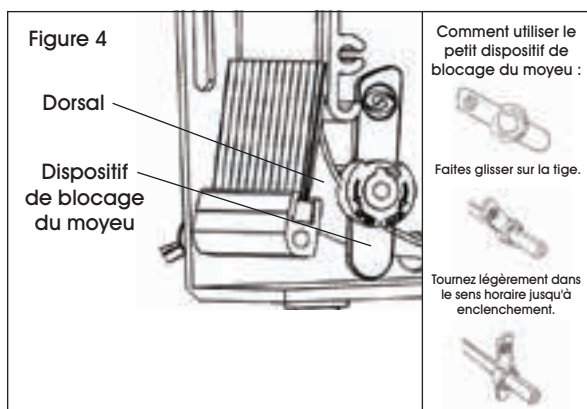

5. Faites passer le dorsal d'étiquettes entre le balai et la plaque de distribution. (Voir Figure 4)
6. Ajustez le dispositif de blocage du moyeu pour guider le matériel.

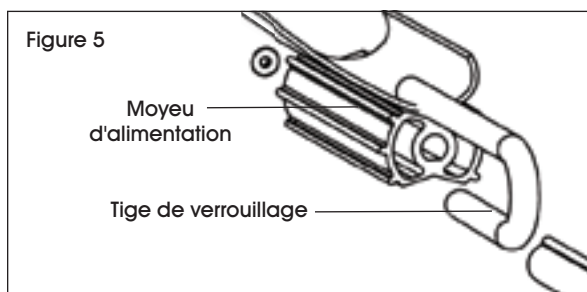

7. Faites glisser la tige de blocage du moyeu d'alimentation. (Voir Figure 5)
8. Fixez le dorsal d'étiquettes sur le moyeu d'alimentation.

RÉGLAGES

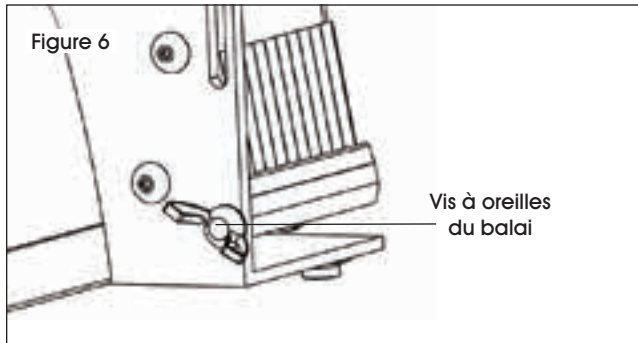

9. Pour appliquer le montant de tension nécessaire à un processus d'alimentation et de détection d'étiquettes adéquats, desserrez la vis à oreilles du balai et appuyez pour accroître la tension, puis resserrez la vis. (Voir Figure 6)

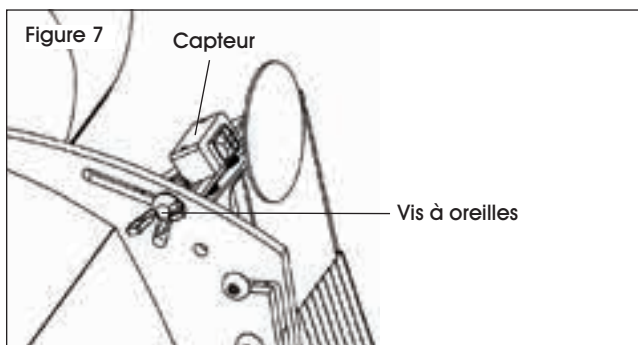

10. Desserrez la vis à oreilles, puis ajustez la plaque de distribution.
11. Orientez le capteur vers le bord supérieur de l'étiquette, puis serrez la vis à oreilles pour fixer le capteur. (Voir Figures 7 et 8)

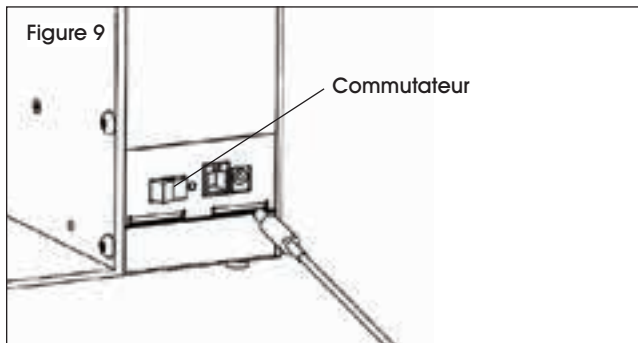
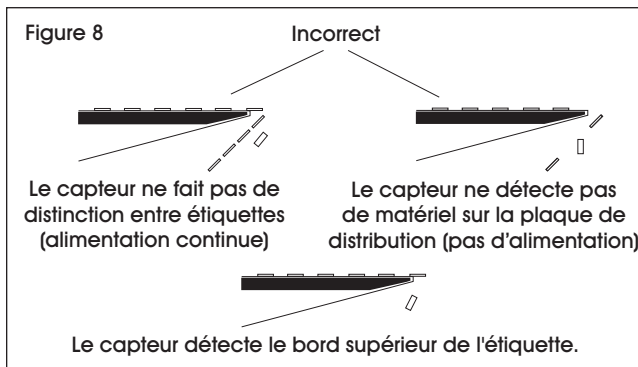

12. Branchez le cordon d'alimentation et appuyez sur le commutateur pour la mise en marche. (Voir Figure 9)