

ULINE H-6979, H-6980, H-6981
H-6982, H-9268

1-800-295-5510
uline.com

MACHINE TABLE

TOOLS NEEDED

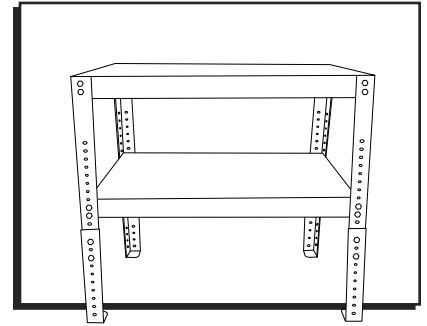

PARTS

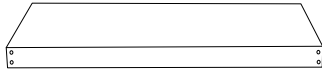

Top Panel x 1

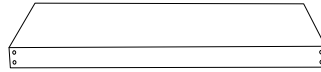

Lower Shelf x 1

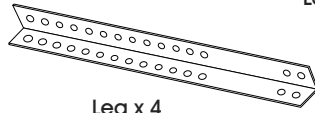

Leg x 4

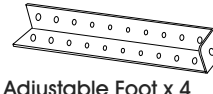

Adjustable Foot x 4



Flange Nut x 48



Bolt x 48

ASSEMBLY

1. Place top panel on a smooth, non-marring surface with top side facing down.
2. Attach legs to outside of top panel using four bolts and four flange nuts on each leg. (See Figure 1)

 **NOTE:** Do not tighten all the way.

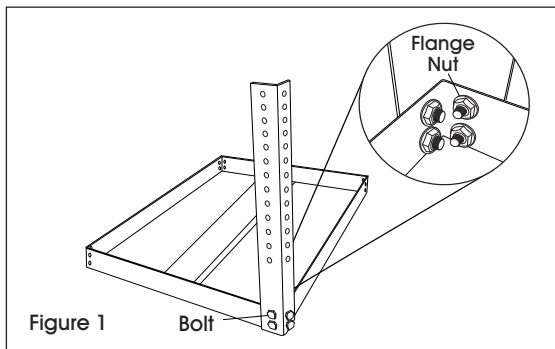

Figure 1

3. Determine desired overall height and lower shelf location.
4. Place lower shelf inside of legs and attach using four bolts and four flange nuts on each leg. Do not tighten. (See Figure 2)

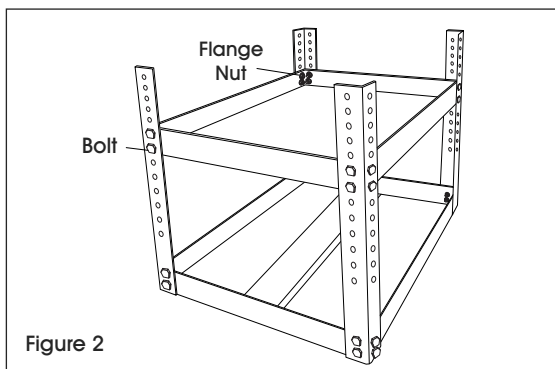

Figure 2

5. Place feet at desired height on outside of legs and attach using four bolts and four flange nuts on each foot. Tighten all bolts. (See Figure 3)

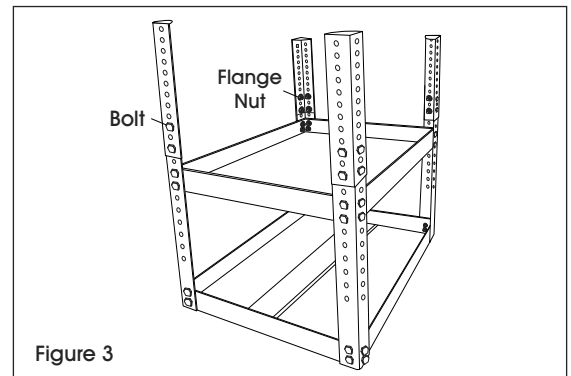

Figure 3

 **NOTE:** If foot and shelf overlap, unscrew one side at a time and replace.

 **NOTE:** Leave at least one open hole between bolt locations.

6. Set machine table upright and check all bolts and nuts for tightness. (See Figure 4)

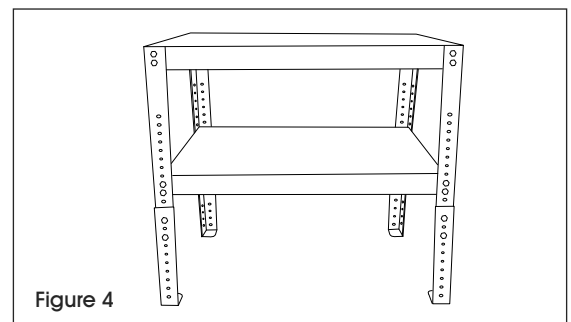
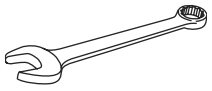
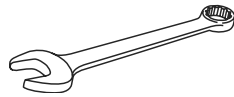

Figure 4

 **NOTE:** If table is not level, loosen and retighten bolts as needed.

MESA PARA MÁQUINAS**HERRAMIENTAS NECESARIAS**

Llave de 13 mm

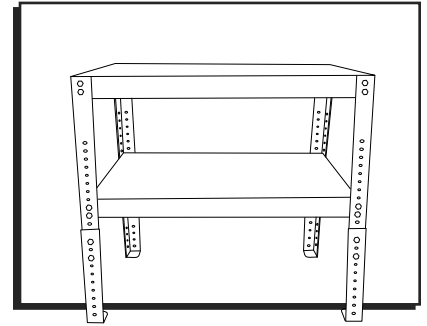
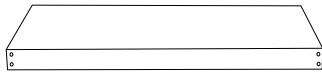

Llave de 14 mm

**PARTES**

1 Panel Superior

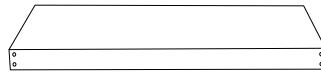

1 Repisa Inferior

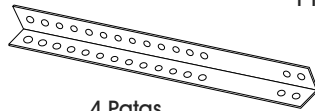

4 Patas

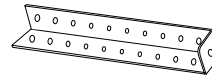

4 Extensores de Altura para Patas



48 Tuercas de Reborde



48 Pernos

ENSAMBLE

1. Coloque el panel superior sobre una superficie lisa que no deje marcas, con el lado superior hacia abajo.
2. Fije las patas al exterior del panel superior y atornille utilizando cuatro pernos y cuatro tuercas de reborde en cada pata. (Vea Diagrama 1)

 **NOTA:** No apriete por completo.

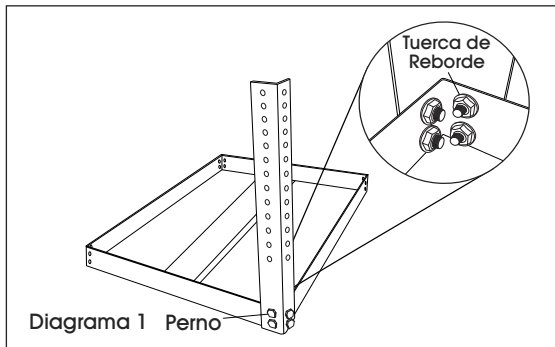

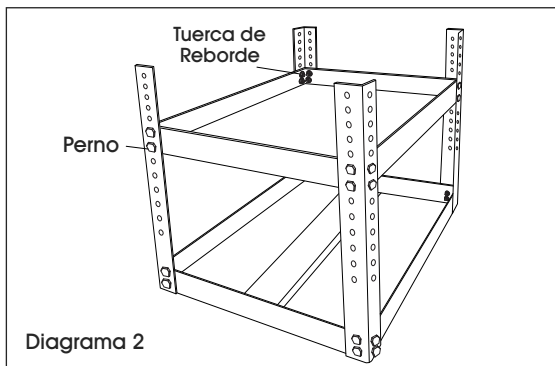

3. Determine la ubicación de la altura total y de la repisa inferior.
4. Coloque la repisa inferior dentro de las patas y fíjela utilizando cuatro pernos y cuatro tuercas de reborde en cada pata. No apriete. (Vea Diagrama 2)

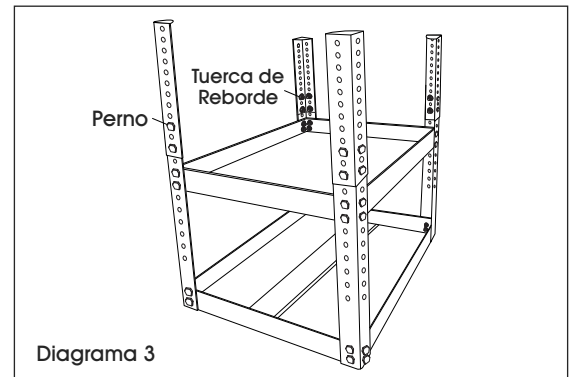

5. Coloque los extensores a la altura deseada en el exterior de las patas y fíjelos utilizando cuatro pernos y cuatro tuercas de reborde en cada extensor de altura. Apriete todos los pernos. (Vea Diagrama 3)



 **NOTA:** Si el extensor de altura y la repisa quedan encimados, desatornille un lado a la vez y reemplace.

 **NOTA:** Deje al menos un orificio abierto entre los pernos colocados.

6. Pare la mesa para máquinas y revise la tensión de todos los pernos y tuercas. (Vea Diagrama 4)

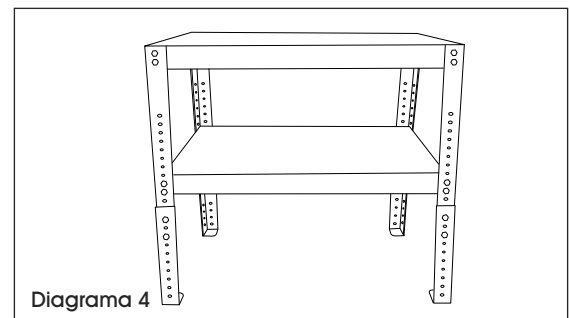

 **NOTA:** Si la mesa no está nivelada, afloje y vuelva a apretar los pernos según sea necesario.

TABLE POUR MACHINES

OUTILS REQUIS



Clé de 13 mm

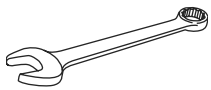
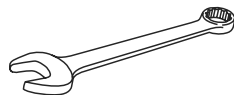

Clé de 14 mm

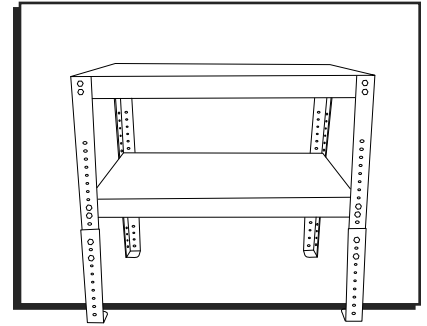

PIÈCES

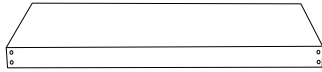

Panneau supérieur x 1

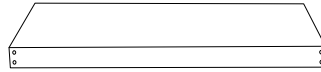

Tablette inférieure x 1

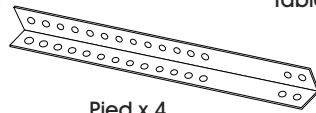

Pied x 4

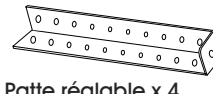

Patte réglable x 4



Écrou à embase x 48



Boulon x 48

MONTAGE

1. Placez le panneau supérieur avec le dessus orienté vers le bas sur une surface lisse et non marquante.
2. Fixez les pieds à l'extérieur du panneau supérieur avec quatre boulons et quatre écrous à embase sur chaque pied. (Voir Figure 1)

REMARQUE : Ne serrez pas complètement.

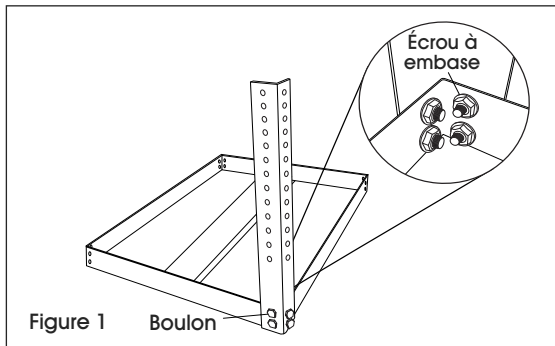

Figure 1 Boulon

3. Déterminez la hauteur totale désirée ainsi que l'emplacement de la tablette inférieure.
4. Installez la tablette inférieure entre les pieds et fixez-la avec quatre boulons et quatre écrous à embase sur chaque pied. Ne serrez pas. (Voir Figure 2)

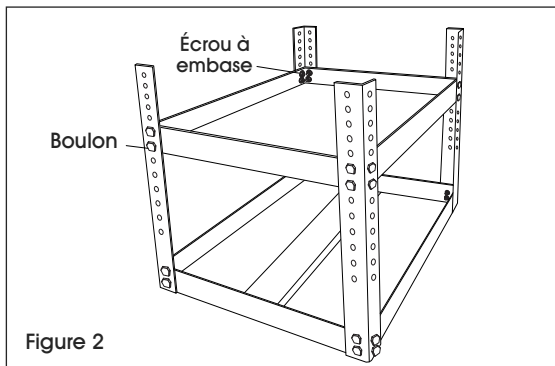

Figure 2

5. Placez les pattes à la hauteur désirée à l'extérieur des pieds et fixez-les avec quatre boulons et quatre écrous à embase sur chaque patte. Serrez tous les boulons. (Voir Figure 3)

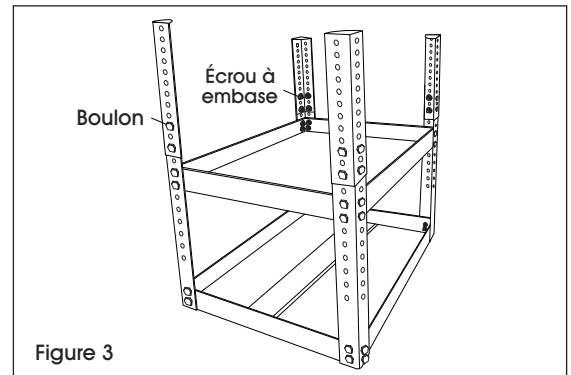

Figure 3

REMARQUE : Si la patte et la tablette se chevauchent, dévissez et réinstallez les côtés un à la fois.

REMARQUE : Gardez au moins un trou de libre entre les emplacements des boulons.

6. Placez la table à l'endroit et vérifiez que tous les boulons et les écrous sont bien serrés. (Voir Figure 4)

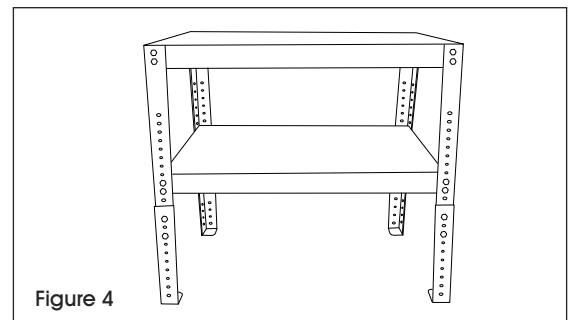

Figure 4

REMARQUE : Si la table est bancale, desserrez et resserrez les boulons au besoin.