

# ULINE

## STAINLESS STEEL WORKTABLE

1-800-295-5510  
uline.com

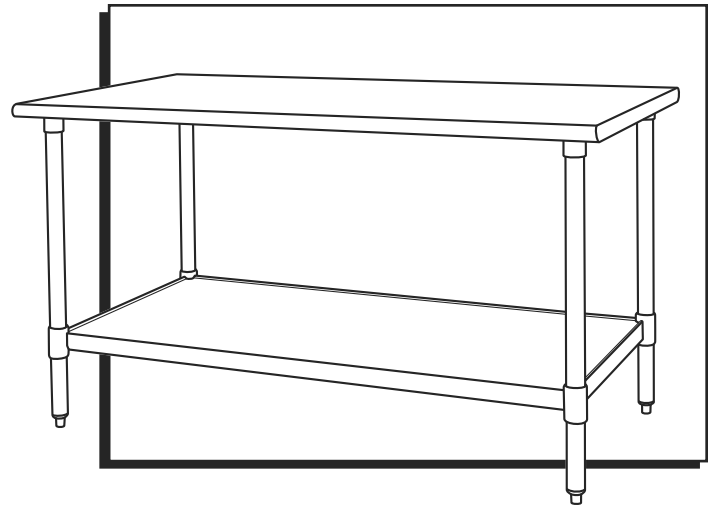

### TOOL NEEDED

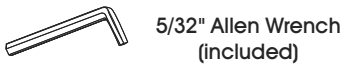

## PARTS

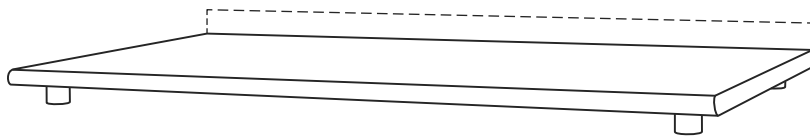

Tabletop x 1

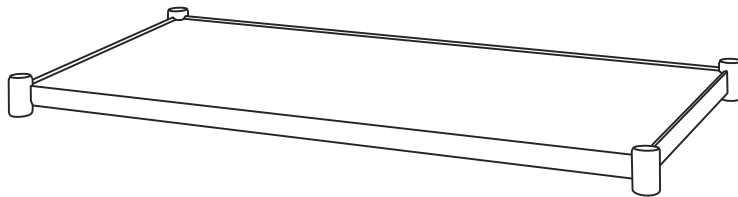

Undershelf x 1



Legs with Adjustable Feet x 4  
(x 6 for 96" Tables)



Set Screw x 16  
(x 24 for 96" Tables)

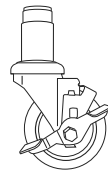

Caster x 4  
(Optional)  
(x 6 for 96" Tables)

## ASSEMBLY

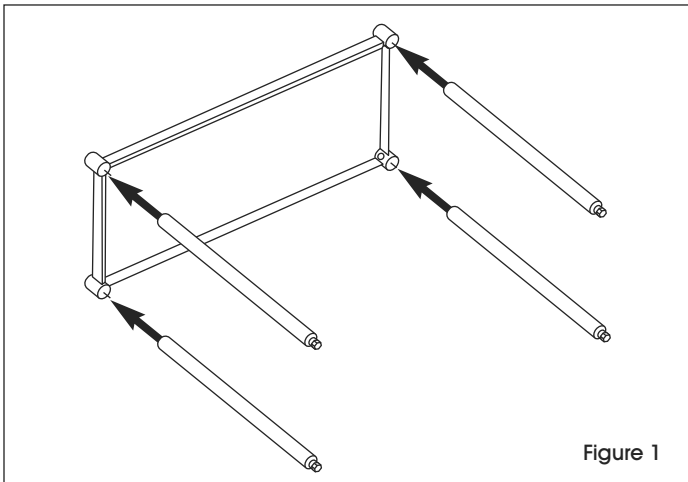

**NOTE:** If purchased with optional casters, adjustable feet will be replaced after complete table assembly.

1. With the undershelf on its side, push the legs through the collars to the desired height. To ensure exact height, mark desired height on each leg with magic marker or grease pencil. (See Figure 1)



**NOTE:** Each leg must be at the same height or shelf collars could fail. Recommended height from the floor to the top of the undershelf is 10" and must be 6" or higher to meet NSF standards.



**NOTE:** Optional casters add 3<sup>3</sup>/<sub>8</sub>" to height.

## ASSEMBLY CONTINUED

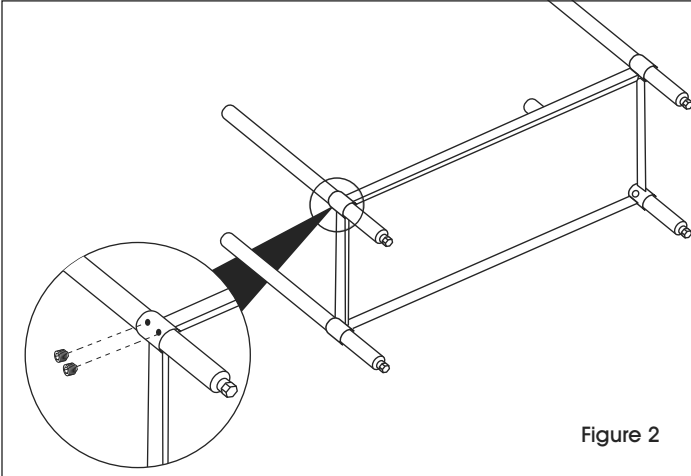

2. Secure legs to undershelf with set screws using 5/32" Allen wrench. (See Figure 2)

 **NOTE:** Undershelf must be level. Use care not to overtighten screws or failure will occur.

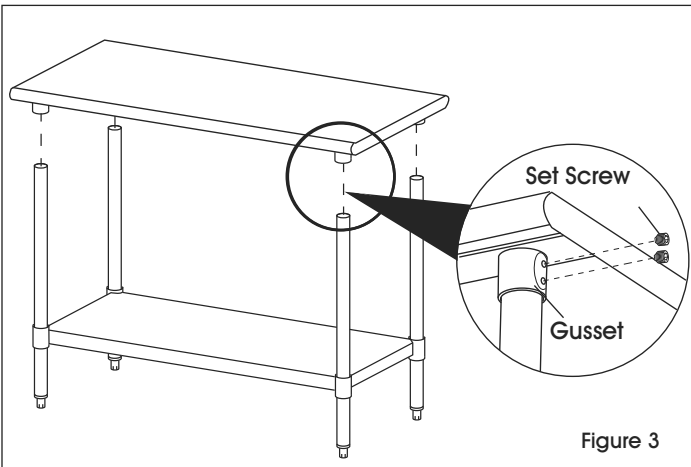

3. Stand table upright and place tabletop onto legs, inserting legs into tabletop gussets. With a 5/32" Allen wrench, tighten set screw on each gusset. (See Figure 3)

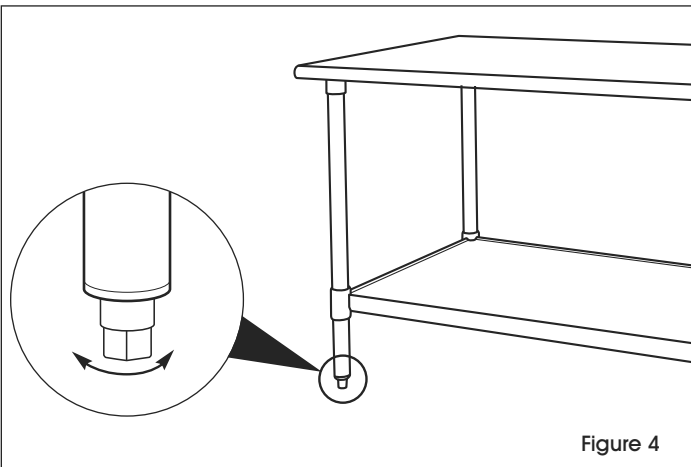

4. Level table with the adjustable feet. Adjustable feet allow approximately 1" of adjustment. (See Figure 4)

## OPTIONAL CASTERS

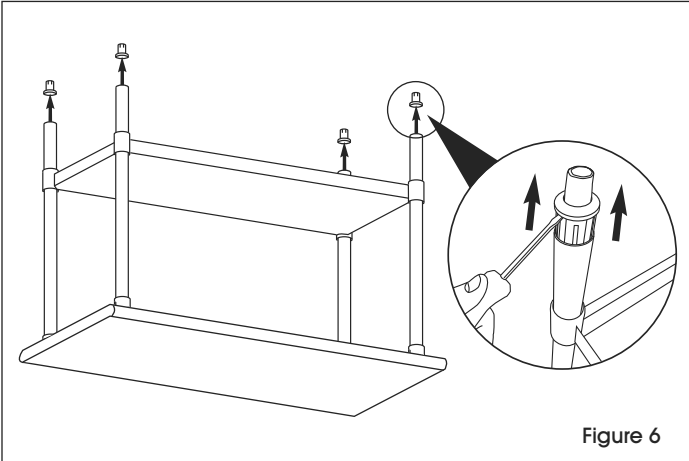

1. Flip the table back over onto a smooth, non-marring surface. Remove adjustable feet from tube legs using a flat head screwdriver. (See Figure 6)

 **NOTE:** You may need to use a rubber mallet or hammer to assist.

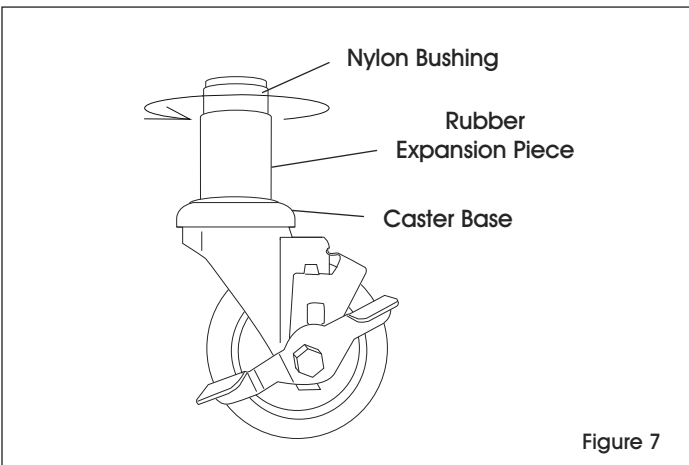

2. Hold caster base and rotate nylon bushing clockwise. This will cause the rubber piece to expand. (See Figure 7)
3. Expand the rubber enough so that it will fit snugly into the tube leg.

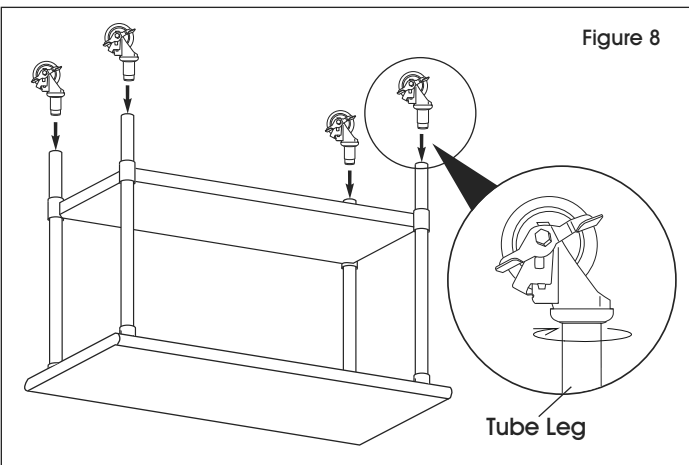

4. With caster fully inserted into the leg, turn clockwise until caster is secured to tube leg. (See Figure 8)

 **NOTE:** If too loose, pull out caster and tighten further. Repeat step 2.

**ULINE**

# MESA DE TRABAJO DE ACERO INOXIDABLE

800-295-5510  
uline.mx

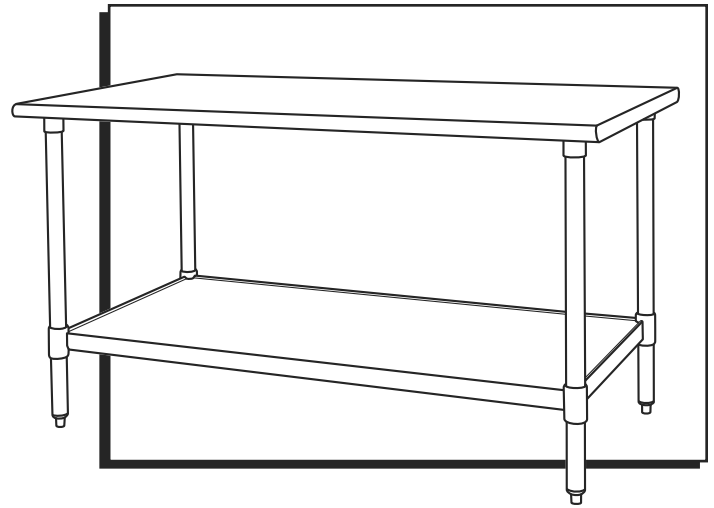

## HERRAMIENTA NECESARIA



Llave Allen de 5/32"  
(incluida)

## PARTES

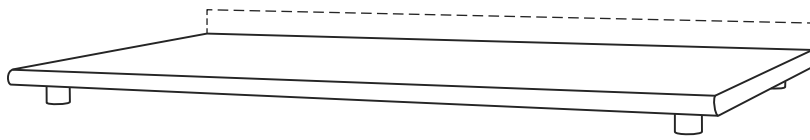

1 Cubierta

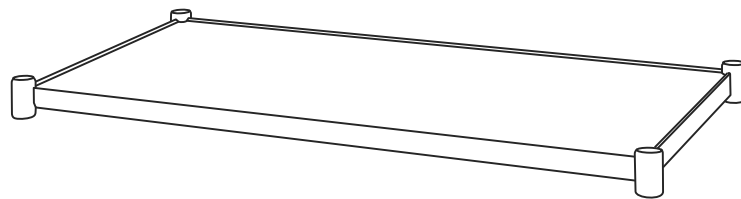

1 Repisa Inferior



4 Patas Ajustables  
(6 para mesas de 96")



16 Tornillos de Sujeción  
(24 para mesas de 96")

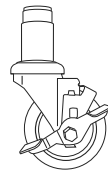

4 Ruedas  
(Opcionales)  
(6 para mesas de 96")

## ENSAMBLE



Diagrama 1



**NOTA:** Si se adquiere con ruedas opcionales, las patas ajustables se reemplazarán después de completar el ensamble de la mesa.

1. Con la repisa inferior de lado, meta las patas en las ranuras a la altura deseada. Para garantizar la altura exacta, marque la altura deseada en cada pata con un marcador de agua o un lápiz de cera. (Vea Diagrama 1)

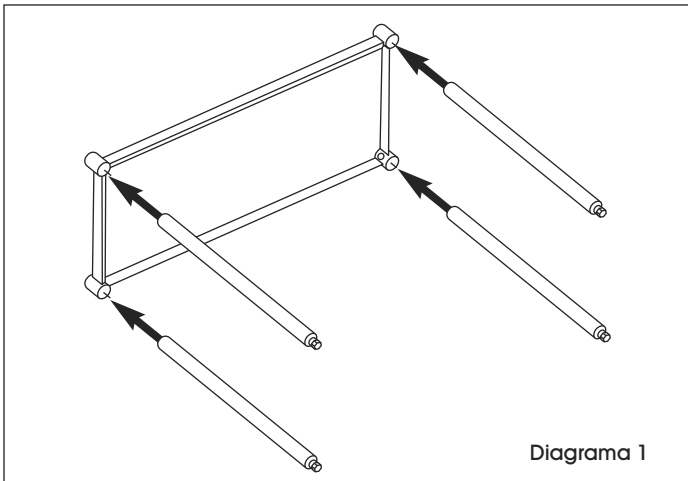

**NOTA:** Cada pata debe estar a la misma altura o las ranuras de las repisas pueden desnivelarse. La altura recomendada del suelo a la parte superior del bajo estante es de 25.4 cm (10") y debe ser de 15.2 cm (6") o mayor para cumplir con las normas NSF.



**NOTA:** Las ruedas opcionales añaden 8.6 cm (3<sup>3</sup>/<sub>8</sub>") a la altura.

## CONTINUACIÓN DEL ENSAMBLE

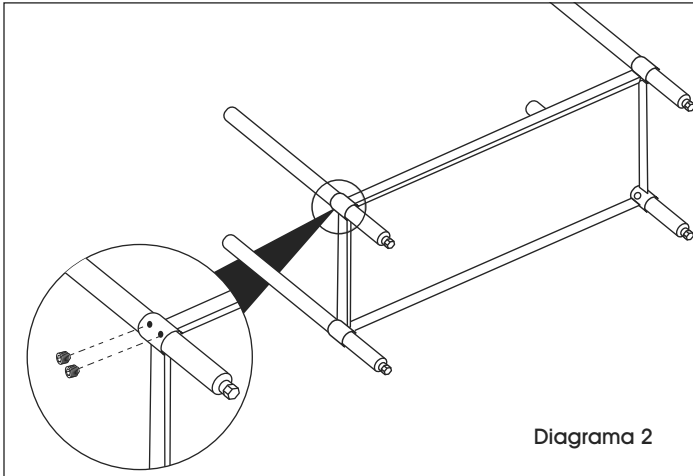

2. Asegure las patas al bajo estante con los tornillos de sujeción utilizando una llave Allen de 5/32". (Vea Diagrama 2)

 **NOTA:** La repisa inferior debe estar nivelada. Tenga cuidado de no apretar los tornillos demasiado, de lo contrario puede averiarse.

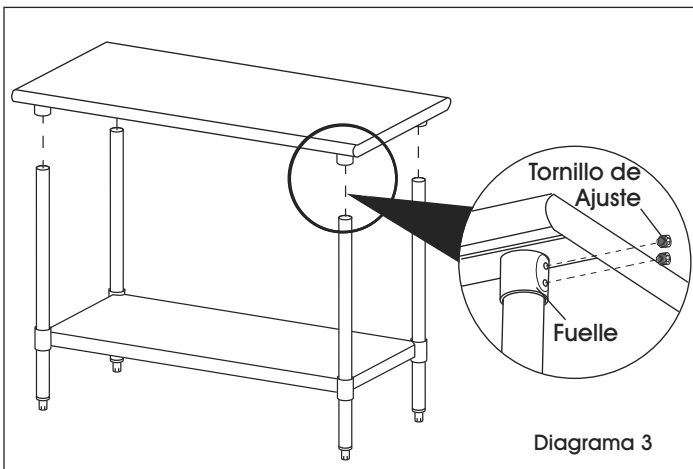

3. Ponga la mesa de pie y coloque la cubierta sobre las patas, insértelas en el refuerzo de la cubierta. Con una llave Allen de 5/32", apriete los tornillos de sujeción en cada refuerzo. (Vea Diagrama 3)

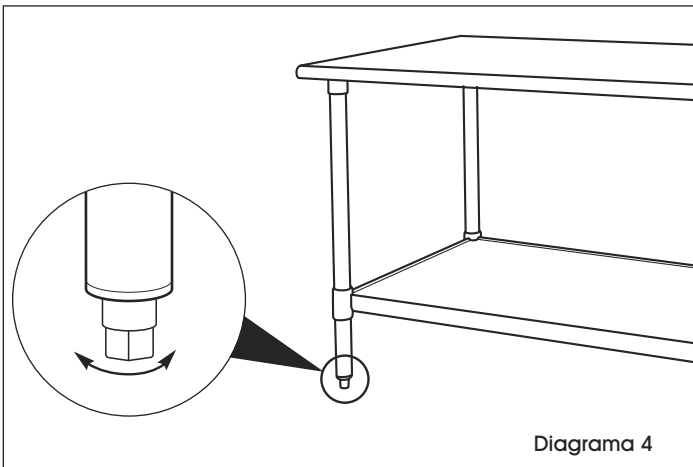

4. Nivele la mesa con las patas ajustables. Las patas ajustables permiten aproximadamente 2.5 cm (1") de ajuste. (Vea Diagrama 4)

## RUEDAS OPCIONALES

Diagrama 6

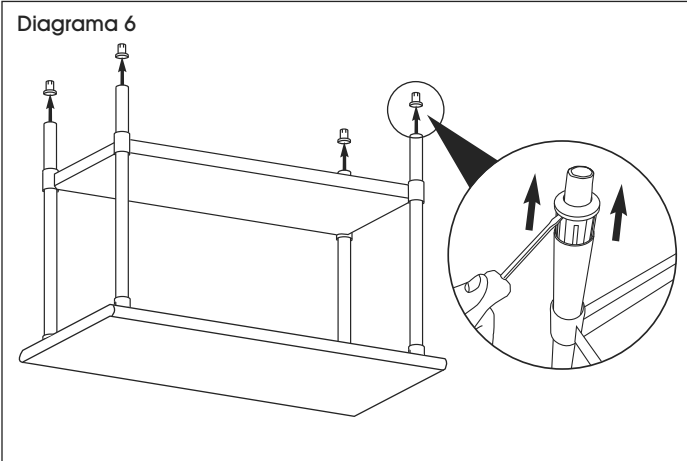

1. Voltee la mesa sobre una superficie lisa, que no deje marcas. Retire las patas ajustables de los tubos usando un destornillador de cabeza plana. (Vea Diagrama 6)

 **NOTA:** Podría necesitar de un mazo de caucho o martillo para ayudarse.

Diagrama 7

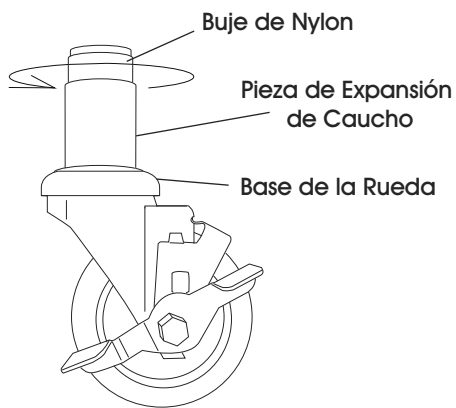

2. Sostenga la base de las ruedas y gire el balero de nylon en el sentido opuesto a las manecillas del reloj. Esto ocasionará que la pieza de caucho se expanda. (Vea Diagrama 7)
3. Estire el caucho lo suficiente para que quepa perfectamente en la pata del tubo.

Diagrama 8

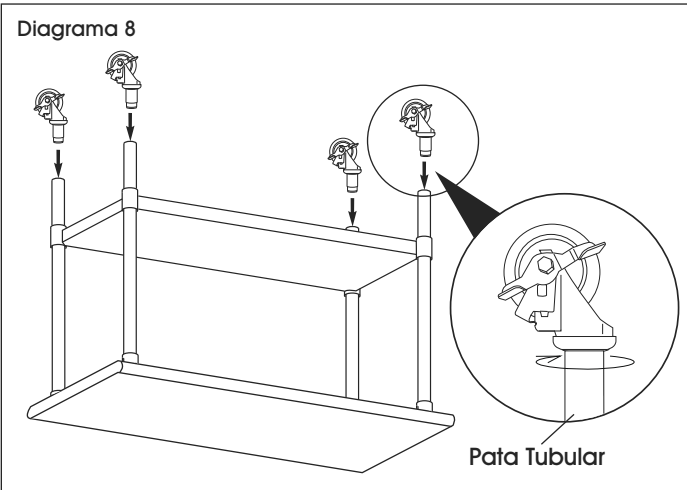

4. Con la rueda completamente dentro de la pata, gire en el sentido de las manecillas del reloj hasta que la rueda quede fija en la pata del tubo. (Vea Diagrama 8)

 **NOTA:** Si queda muy floja, saque la rueda y apriete más. Repita el paso 2.

**ULINE**

# TABLE DE TRAVAIL EN ACIER INOXYDABLE

1-800-295-5510

uline.ca

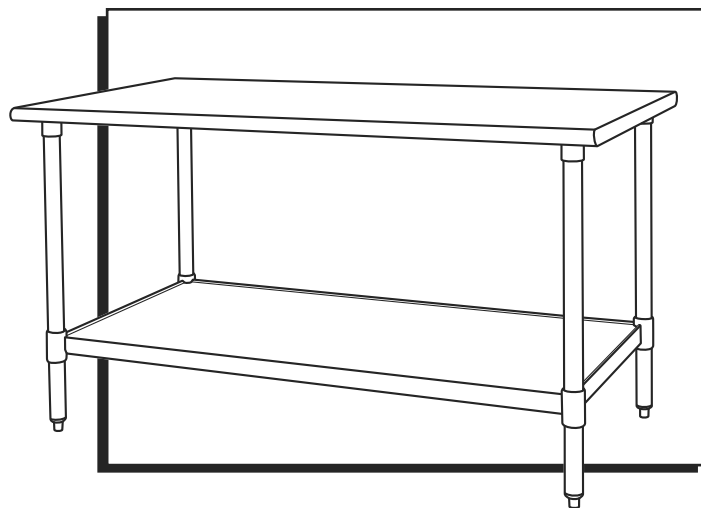

## OUTIL REQUIS



Clé Allen de 5/32 po  
(incluse)

## PIÈCES

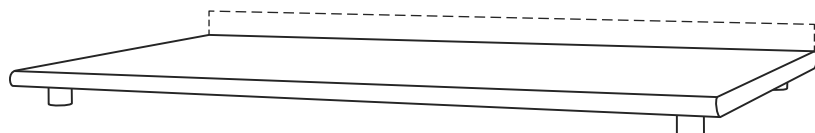

Surface de table x 1

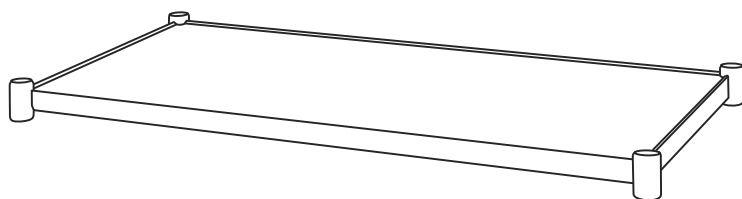

Tablette inférieure x 1



Pieds avec pattes réglables x 4  
(x 6 pour les tables de 96 po)



Vis de réglage x 16  
(x 24 pour les tables de 96 po)

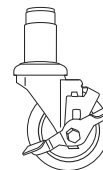

Roulette x 4 (optionnel)  
(x 6 pour les tables de 96 po)

## MONTAGE

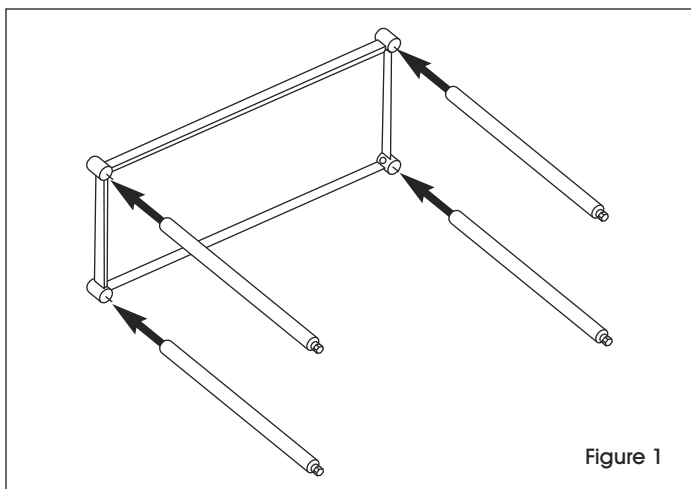

**REMARQUE :** Si la table a été achetée avec les roulettes optionnelles, les pattes réglables seront remplacées après le montage complet.

1. En gardant la tablette inférieure sur son côté, poussez les pieds à travers les cols jusqu'à la hauteur désirée. Pour assurer la hauteur exacte, marquez la hauteur désirée sur chaque pied avec un marqueur magique ou un crayon à laboratoire. (Voir Figure 1)



**REMARQUE :** Chaque pied doit être de la même hauteur sinon les cols seront défaillants. La hauteur recommandée à partir du plancher au haut de la tablette inférieure est de 25,4 cm (10 po) et doit être de 15,2 cm (6 po) ou plus afin de répondre aux exigences de la NSF.



**REMARQUE :** Les roulettes optionnelles ajoutent 8,6 cm (3 3/8 po) à la hauteur.

## MONTAGE SUITE

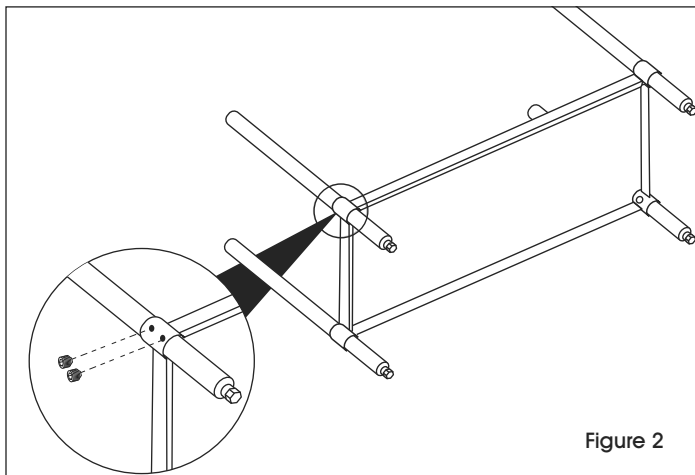

- Fixez les pieds à la tablette inférieure à l'aide des vis de réglage et de la clé Allen de 5/32 po. (Voir Figure 2)



**REMARQUE :** La tablette inférieure doit être nivelée. Faites attention de ne pas trop serrer les vis ou une défaillance se produira.

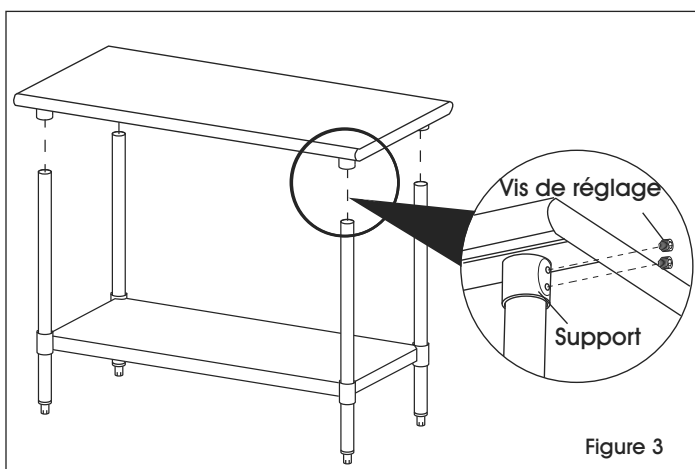

- Placez la table à la verticale et installez la surface de table sur les pieds tout en les insérant dans les supports de la surface. À l'aide de la clé Allen de 5/32 po, serrez les vis se trouvant sur chaque support. (Voir Figure 3)

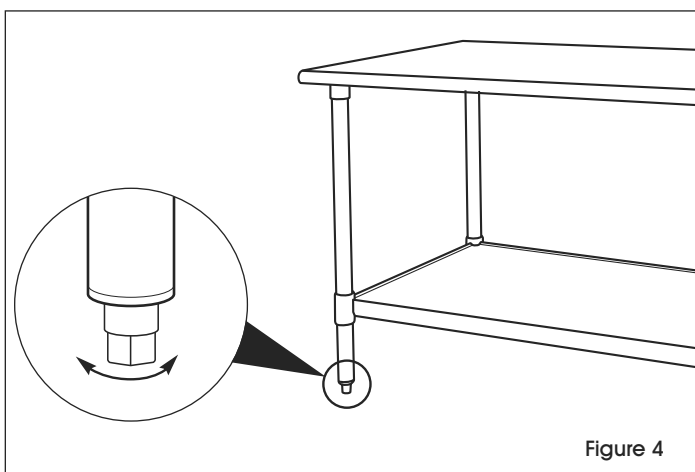

- Nivelez la table en ajustant les pattes. Les pattes réglables permettent environ 2,5 cm (1 po) d'ajustement. (Voir Figure 4)



## ROULETTES OPTIONNELLES

Figure 6

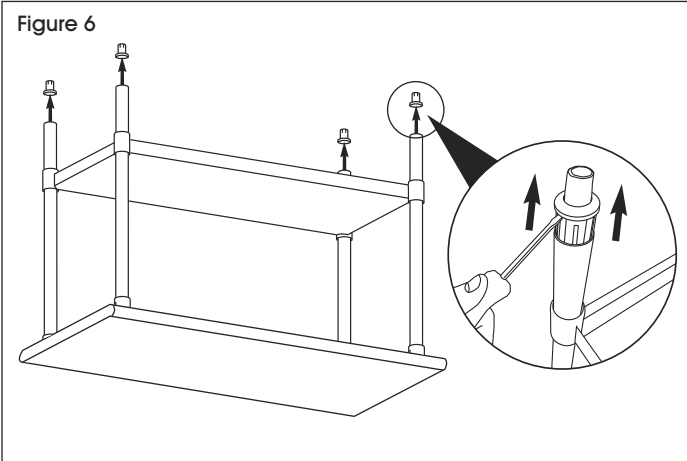

1. Tournez la table à l'envers sur une surface plane et non marquante. Retirez les pattes réglables des tubes de pied à l'aide d'un tournevis à tête plate. (Voir Figure 6)



**REMARQUE :** Au besoin, utilisez un maillet en caoutchouc ou un marteau pour vous aider.

Figure 7

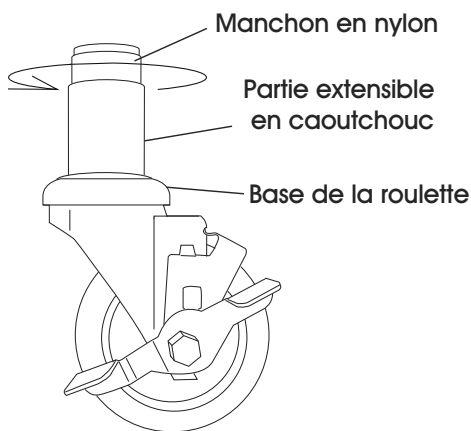

2. Tenez la base de la roulette et faites tourner le manchon en nylon dans le sens horaire. Ceci causera l'élargissement de la partie en caoutchouc. (Voir Figure 7)
3. Élargissez le caoutchouc afin qu'il se fixe parfaitement dans le tube de pied.

Figure 8

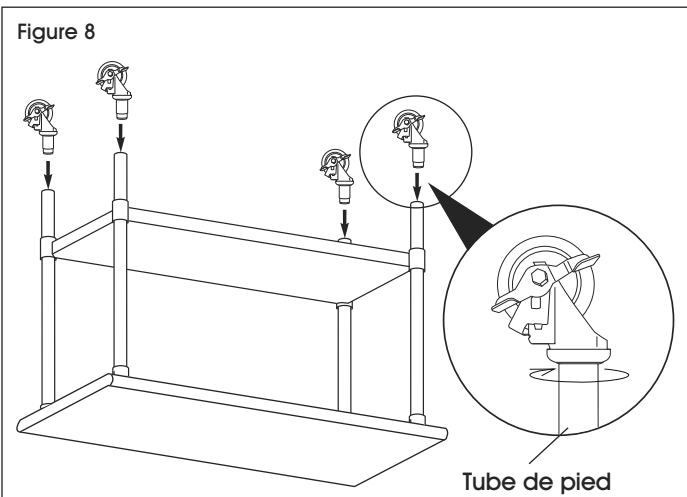

4. Une fois la roulette complètement insérée dans le pied, tournez dans le sens horaire jusqu'à ce que la roulette soit fixée au tube de pied. (Voir Figure 8)



**REMARQUE :** Si la roulette est trop lâche, retirez-la et serrez davantage. Répétez l'étape 2.