

ULINE H-6256, H-6257 H-6258 STAINLESS STEEL WORKTABLE WITHOUT BOTTOM SHELF

1-800-295-5510
uline.com

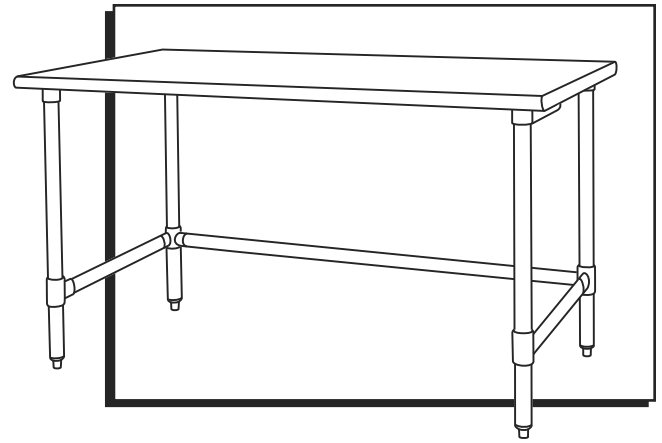

TOOL NEEDED



5/32" Allen Wrench
(included)

PARTS

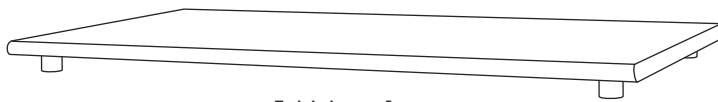

Tabletop x 1

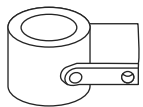

End Casting x 2



Set Screw x 14

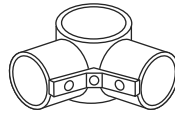

Corner Casting x 2



Legs with
Adjustable Feet x 4



Side
Crossbracing
x 2



Rear
Crossbracing
x 1

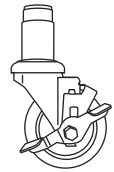



Caster x 4
(Optional)

ASSEMBLY

1. Affix corner and end castings to rear and side crossbracing. Secure crossbracing to castings with set screws using 5/32" Allen wrench. (See Figure 1)

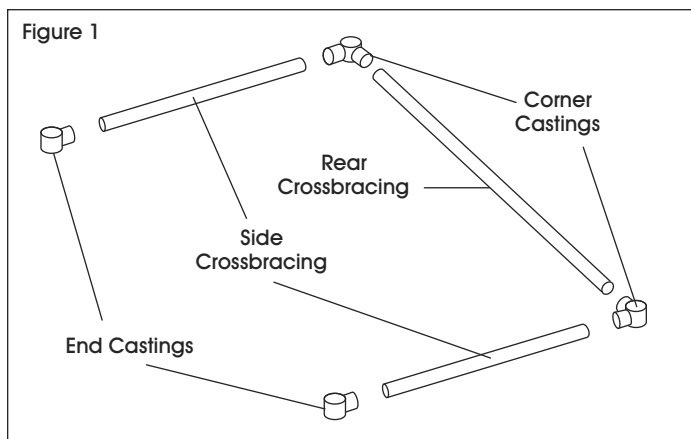
 **NOTE:** Use care not to over-tighten screws or failure may occur.



 **NOTE:** If purchased with optional casters, adjustable feet will be replaced after complete table assembly.

2. With crossbrace on its side, push legs through the casting collars to the desired height. To ensure exact height, mark desired height on each leg with magic marker or grease pencil. (See Figure 2)

 **NOTE:** Each leg must be at the same height or casting collars could fail. Recommended height from the floor to the top of the crossbracing is 10" and must be 6" or higher to meet NSF standards.

 **NOTE:** Optional casters add 3 3/8" to height.

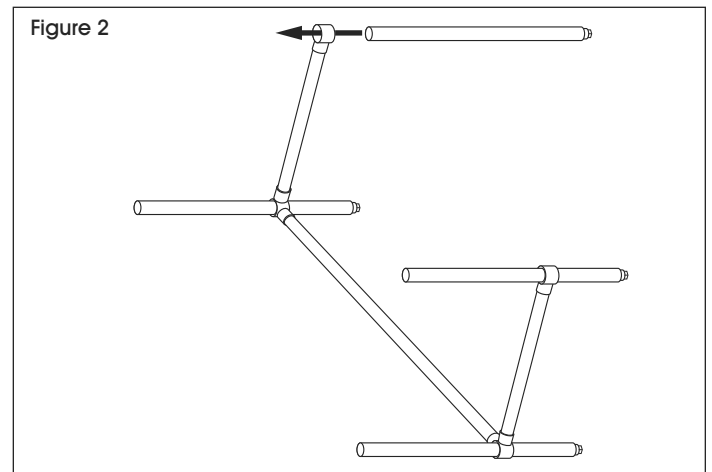

ASSEMBLY CONTINUED

3. Secure legs to crossbrace with set screws using 5/32" Allen wrench. (See Figure 3)

Figure 3

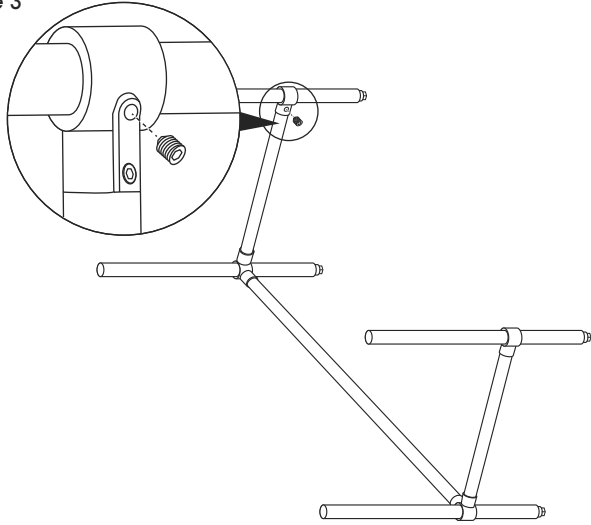

4. Stand table upright and place tabletop onto legs, inserting legs into the tabletop gussets. With a 5/32" Allen wrench, tighten set screw on each gusset. (See Figure 4)

Figure 4

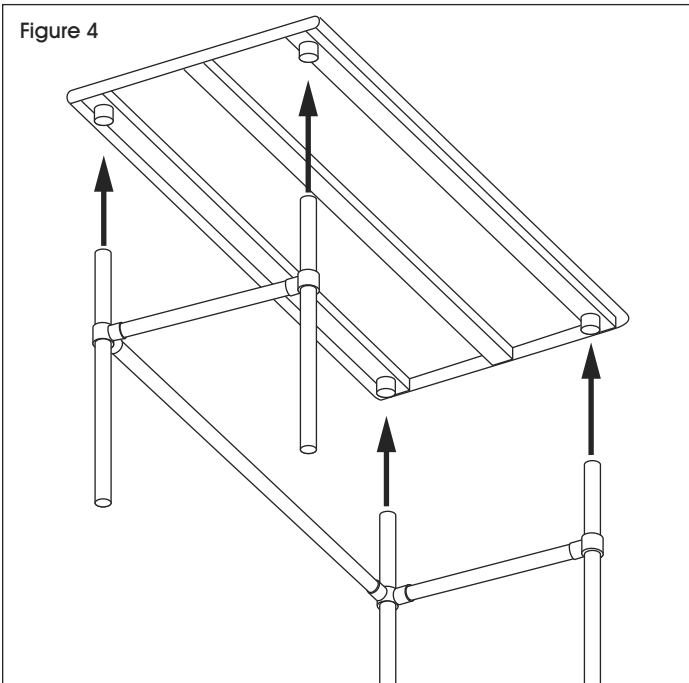

5. Level table with the adjustable feet. Adjustable feet allow approximately 1" of adjustment. (See Figure 5)

Figure 5

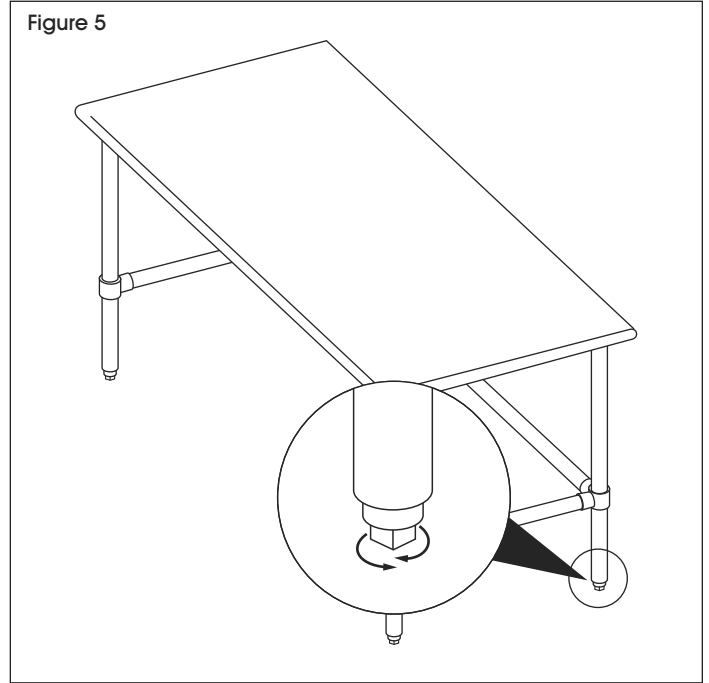

OPTIONAL CASTERS

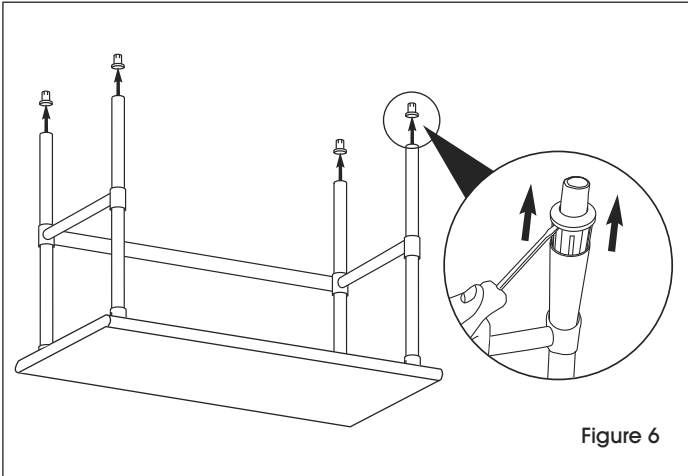

1. Flip the table back over onto a smooth, non-marring surface. Remove adjustable feet from legs using a flat head screwdriver. (See Figure 6)

 **NOTE:** You may need to use a rubber mallet or hammer to assist.

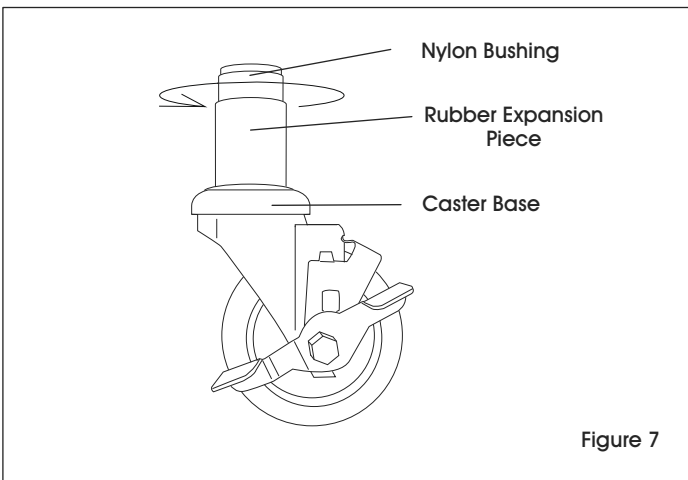

2. Hold caster base and rotate nylon bushing clockwise. This will cause the rubber piece to expand. (See Figure 7)
3. Expand the rubber enough so that it will fit snugly into the tube leg.

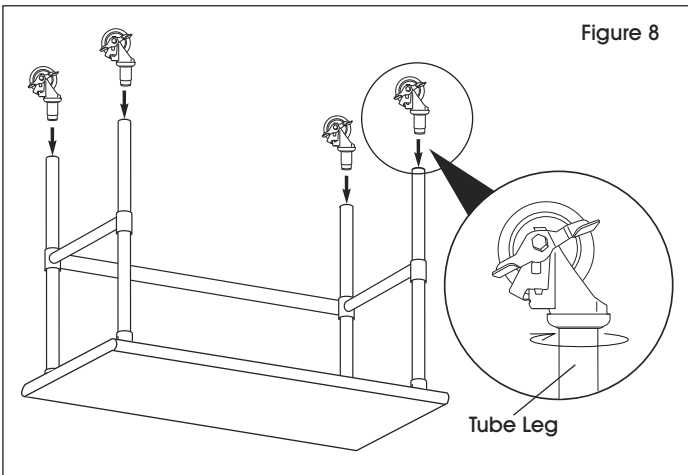

4. With caster fully inserted into the leg, turn clockwise until caster is secured to tube leg. (See Figure 8)

 **NOTE:** If too loose, pull out caster and tighten further. Repeat step 2.

ULINE

1-800-295-5510
uline.com



H-6256, H-6257
H-6258

800-295-5510
uline.mx

MESA DE TRABAJO DE ACERO INOXIDABLE SIN REPISA INFERIOR

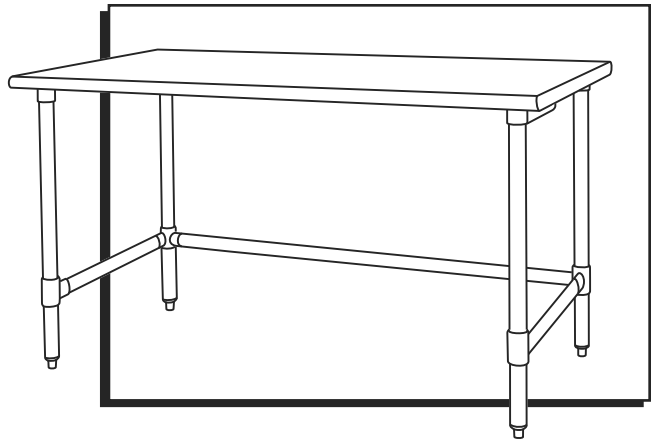

HERRAMIENTA NECESARIA



Llave Allen de 5/32"
(Incluida)

PARTES

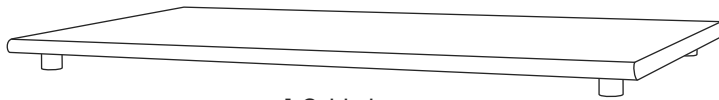

1 Cubierta

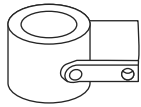

2 Aros de los Extremos



14 Tornillos de Ajuste

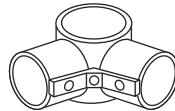

2 Aros de las Esquinas



4 Patas con Niveladores



2 Soportes Laterales



1 Soporte Posterior

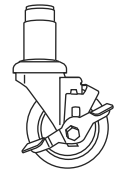

4 Ruedas (Opcionales)

ENSAMBLE

1. Fije los aros de las esquinas y los extremos a los soportes posterior y laterales. Asegure los soportes a los aros con los tornillos de ajuste utilizando la llave Allen de 5/32". (Vea Diagrama 1)



NOTA: No apriete demasiado los tornillos o podría dañar las partes.

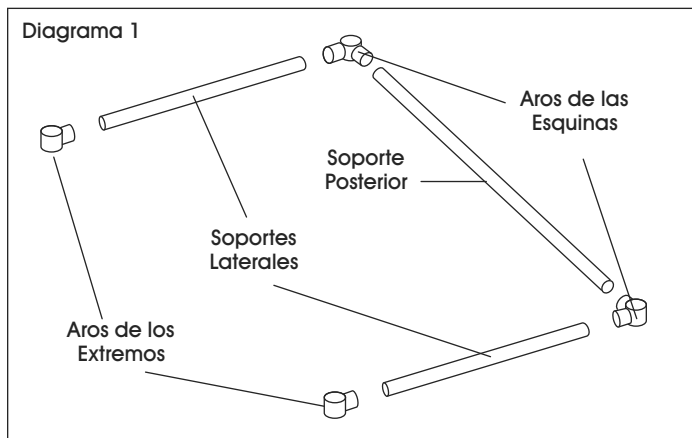

NOTA: Si la compró con ruedas opcionales, los niveladores serán reemplazados después de terminar el ensamble de la mesa.

2. Con el soporte de lado, introduzca las patas a la altura deseada a través de los aros. Para asegurarse de la altura exacta, marque la altura deseada en cada pata con un marcador de agua o lápiz litográfico. (Vea Diagrama 2)



NOTA: Cada pata debe estar a la misma altura o los aros podrían quebrarse. La altura recomendada del piso a la parte superior de los soportes es de 25 cm (10") y debe ser 15 cm (6") o más para cumplir con los estándares de NSF (EUA).



NOTA: Las ruedas opcionales agregan 8.6 cm (3³/₈") a la altura.

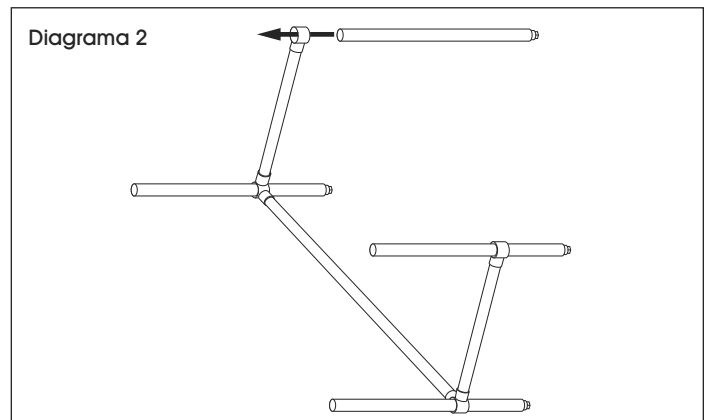

CONTINUACIÓN DE ENSAMBLE

3. Asegure el soporte a las patas con los tornillos de ajuste utilizando la llave Allen de 5/32". (Vea Diagrama 3)

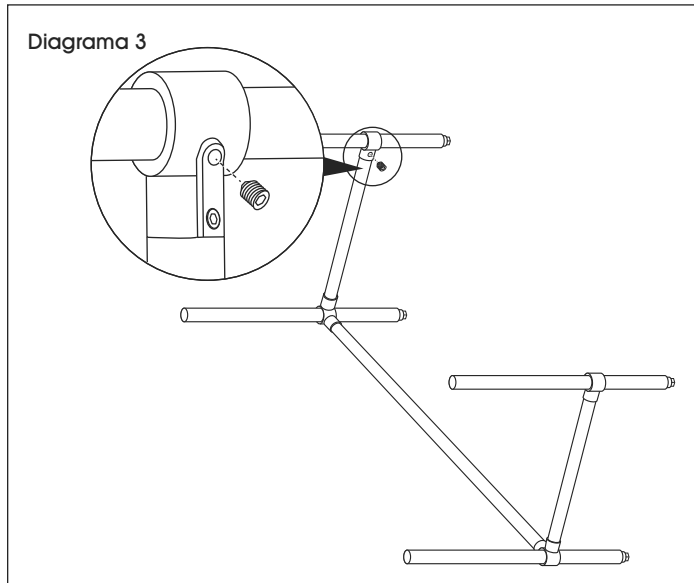

4. Ponga la mesa de pie y coloque la cubierta sobre las patas, insertándolas en los soportes circulares inferiores. Apriete los tornillos de ajuste en cada soporte circular inferior con la llave Allen de 5/32". (Vea Diagrama 4)

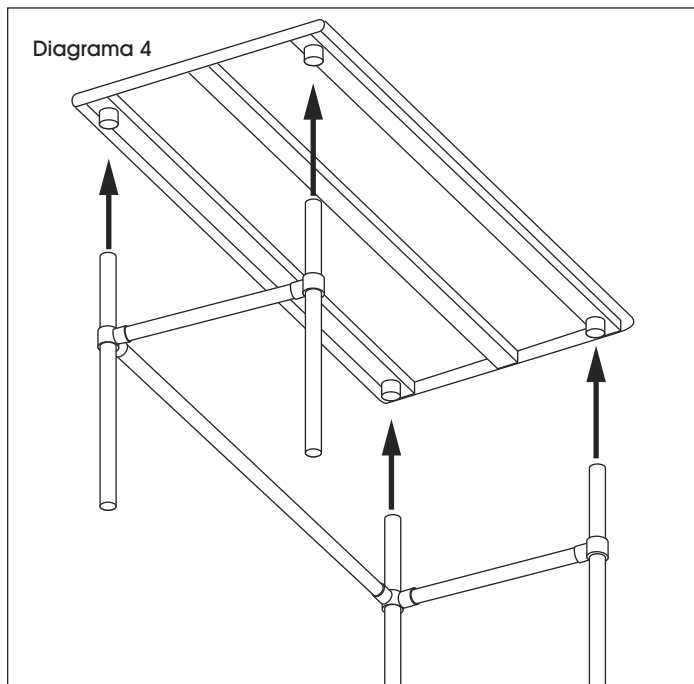

5. Establezca la altura de la mesa con los niveladores. Los niveladores permiten aproximadamente 2.5 cm (1") de ajuste. (Vea Diagrama 5)

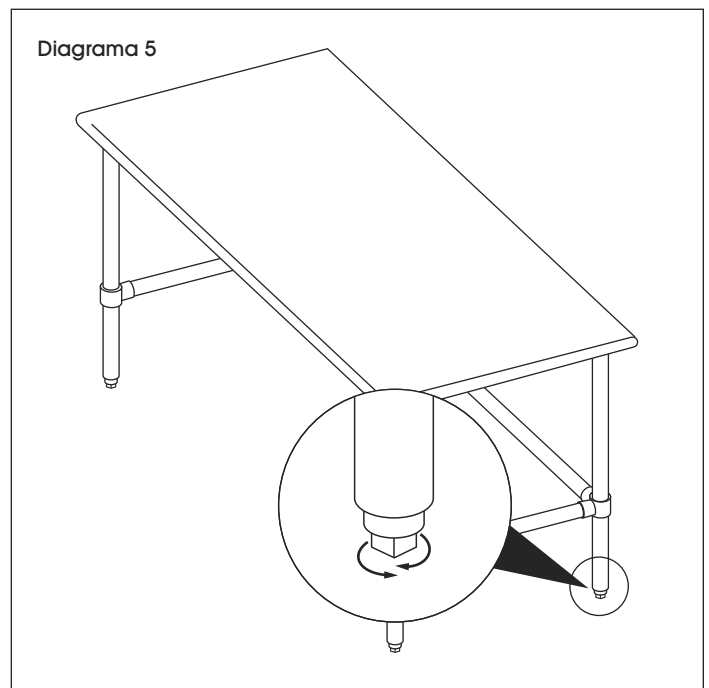

RUEDAS OPCIONALES

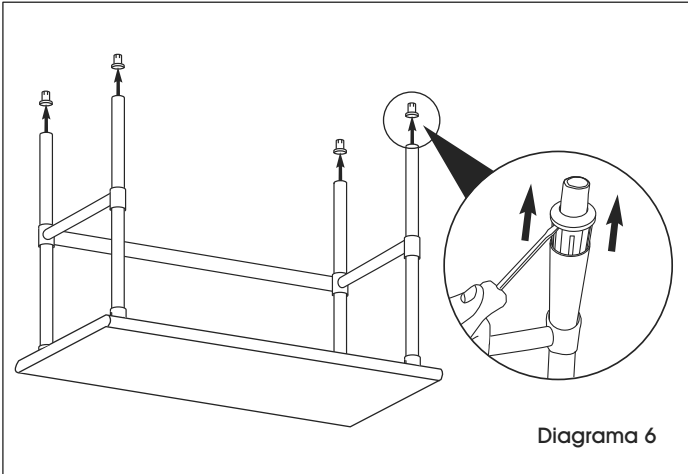

1. Voltee la mesa sobre una superficie lisa que no deje marcas. Retire los niveladores de las patas utilizando un destornillador de cabeza plana. (Vea Diagrama 6)



NOTA: Tal vez tenga que utilizar un mazo de caucho o martillo.

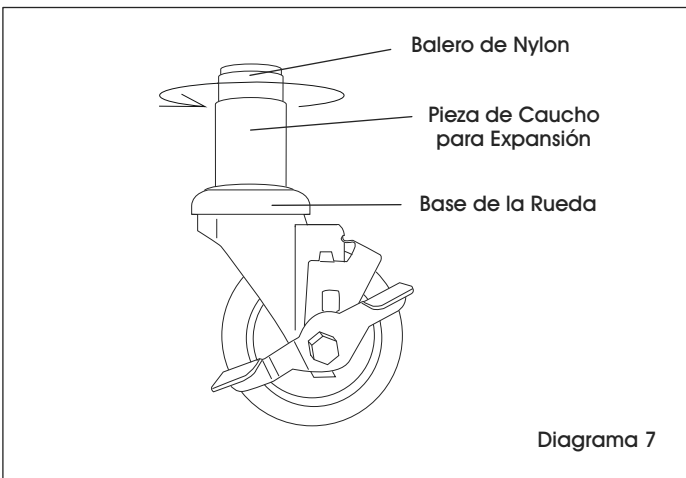

2. Sostenga la base de la rueda y gire el balero de nylon en el sentido de las manecillas del reloj. Esto hará que la pieza de caucho se expanda. (Vea Diagrama 7)
3. Expanda el caucho lo suficiente hasta que encaje perfectamente dentro de la pata tubular.

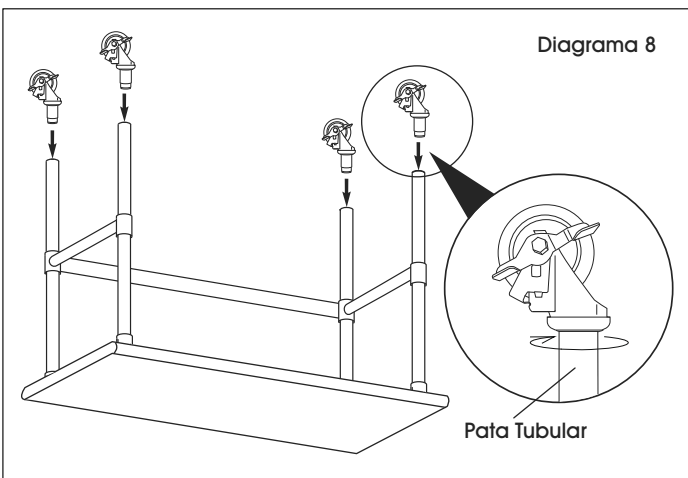

4. Con la rueda completamente dentro de la pata, gírela en el sentido de las manecillas del reloj hasta que la rueda quede asegurada en la pata tubular. (Vea Diagrama 8)



NOTA: Si queda muy floja, retire la rueda y apriétela más. Repita el paso 2.

ULINE

800-295-5510
uline.mx

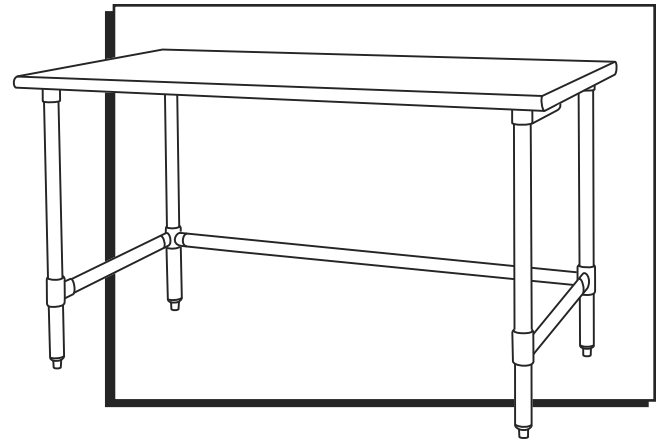
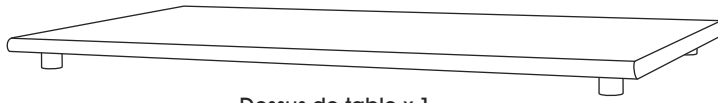
ULINEH-6256, H-6257
H-62581-800-295-5510
uline.ca**TABLE DE TRAVAIL EN
ACIER INOXYDABLE
SANS TABLETTE DU BAS****OUTIL REQUIS**Clé Allen de
5/32 po (inclus)**PIÈCES**

Dessus de table x 1

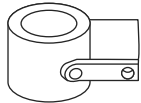

Raccord d'extrémité x 2



Vis de réglage x 14

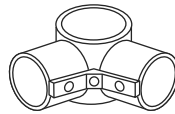

Raccord de coin x 2

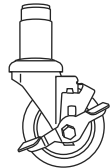
Pieds avec pattes
ajustables x 4Entretoise
latérale x 2Entretoise
arrière x 1Roulette x 4
(optionnel)**MONTAGE**

1. Installez les raccords d'angle et d'extrémité sur les entretoises arrière et latérales. Fixez l'entretoise aux raccords en utilisant des vis de réglage et la clé Allen de 5/32 po. (Voir Figure 1)

REMARQUE : Une défaillance peut s'ensuivre si les vis sont trop serrées.

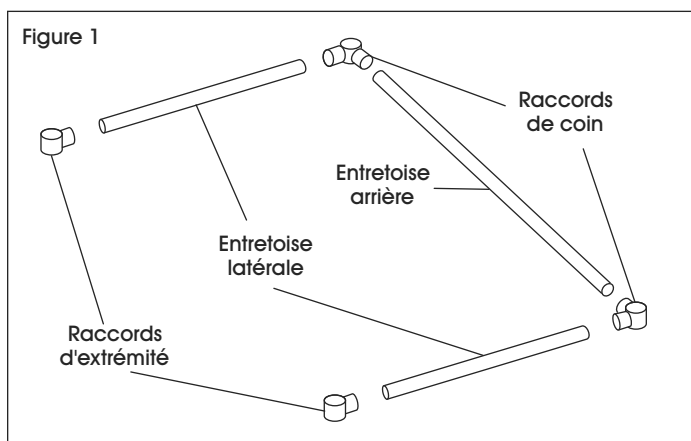

REMARQUE : Si la table a été achetée avec les roulettes optionnelles, les pattes réglables seront remplacées par celles-ci après le montage complet de la table.

2. Placez l'entretoise couchée sur son côté, puis insérez les pieds à travers les raccords jusqu'à la hauteur désirée. Afin d'appliquer la hauteur exacte, inscrivez la hauteur désirée sur chaque pied avec un marqueur effaçable. (Voir Figure 2)

REMARQUE : Les pieds doivent être à la même hauteur, sinon les raccords peuvent défaillir. La hauteur recommandée, à partir du plancher au haut de l'entretoise, est de 25 cm (10 po) et doit mesurer 15 cm (6 po) ou plus pour respecter les normes de la NSF.

REMARQUE : Les roulettes optionnelles ajoutent 8,6 cm (3 3/8 po) à la hauteur.

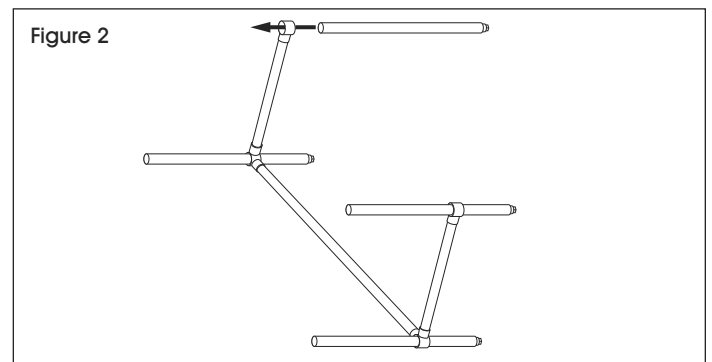

MONTAGE SUITE

3. Fixez les pieds à l'entretoise en utilisant les vis de réglage de 5/32 po et la clé Allen. (Voir Figure 3)

Figure 3

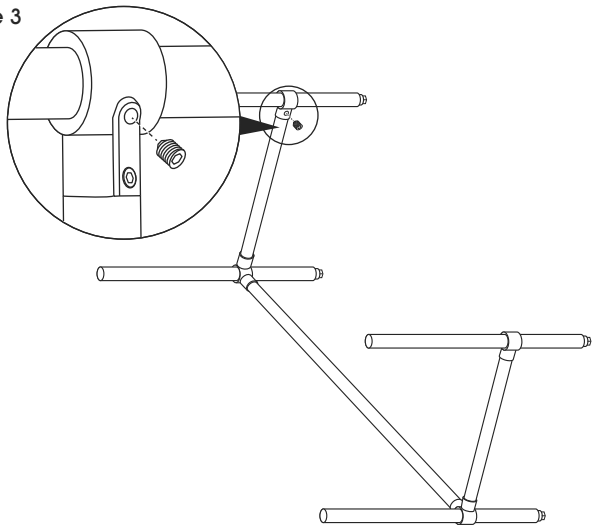

4. Placez la table à la verticale, puis en insérant les pieds dans les goussets de la table, apposez le dessus de table sur les pieds. À l'aide de la clé Allen de 5/32 po, serrez les vis de réglage de chaque gousset. (Voir Figure 4)

Figure 4

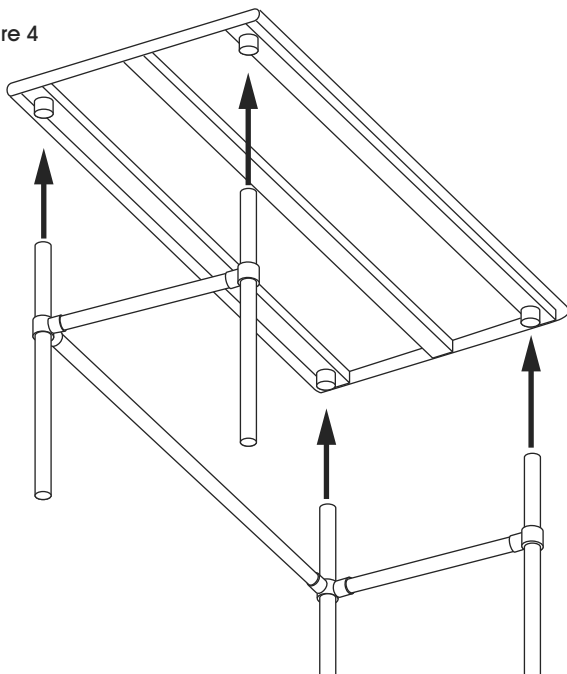

5. Nivelez la table à l'aide des pattes réglables. Les pattes réglables offrent une variation d'ajustement d'environ 2,5 cm (1 po). (Voir Figure 5)

Figure 5

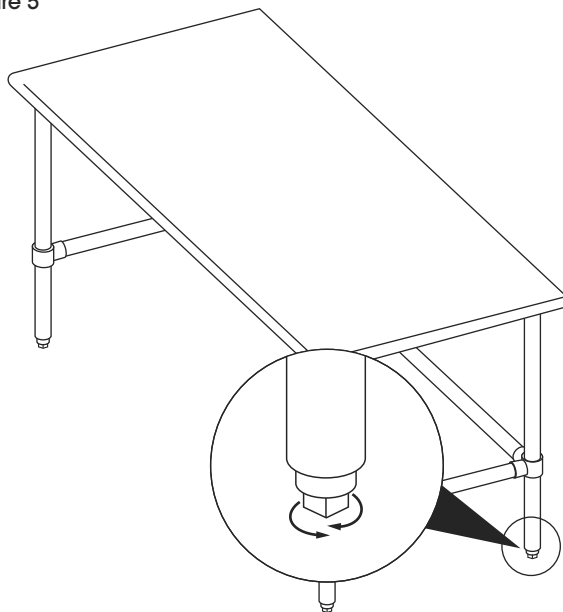

ROULETTES OPTIONNELLES

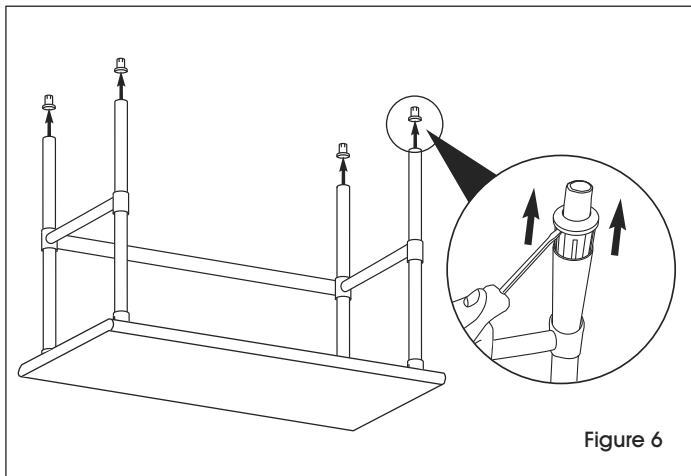

Figure 6

1. Retournez la table à l'envers sur une surface lisse et non marquante. Retirez les pattes réglables des pieds à l'aide d'un tournevis cruciforme. (Voir Figure 6)



REMARQUE : Un maillet en caoutchouc ou un marteau sera peut-être nécessaire pour cette tâche.

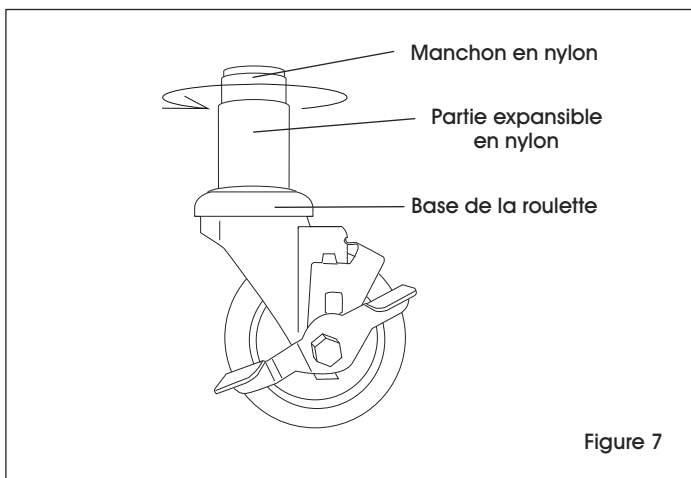

Figure 7

2. Tenez la base de la roulette, puis tournez le manchon en nylon dans le sens horaire. Ce mouvement actionnera l'expansion de la partie en caoutchouc. (Voir Figure 7)
3. Élargissez le caoutchouc jusqu'à ce qu'il soit sécurisé dans le tube du pied.

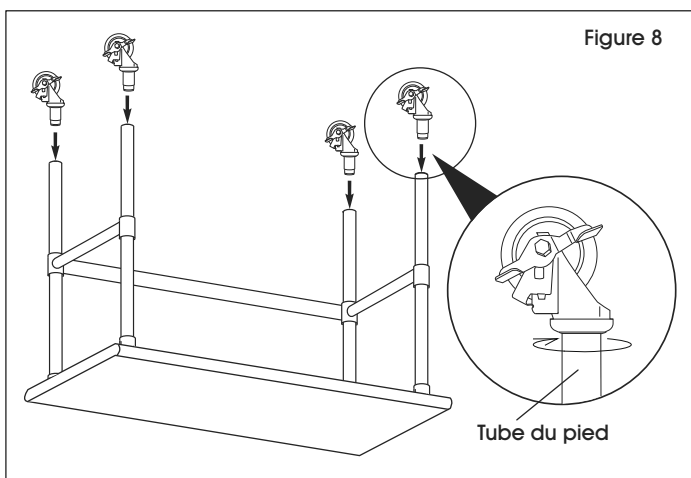

Figure 8

4. Lorsque la roulette est insérée complètement dans le pied, tournez la roulette dans le sens horaire jusqu'à ce qu'elle soit bien sécurisée. (Voir Figure 8)



REMARQUE : Si la roulette est lâche, retirez-la et serrez de nouveau. Répétez l'étape 2.

ULINE

1-800-295-5510
uline.ca