

ULINE H-5534

KEG HAND TRUCK

WITH SOLID RUBBER WHEELS

1-800-295-5510
uline.com

Para Español, vea páginas 3-4.
Pour le français, consulter les pages 5-6.

TOOLS NEEDED



6mm Allen Wrench



13mm Wrench

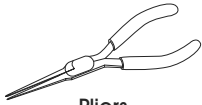

Pliers

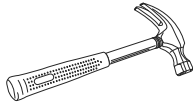

Hammer

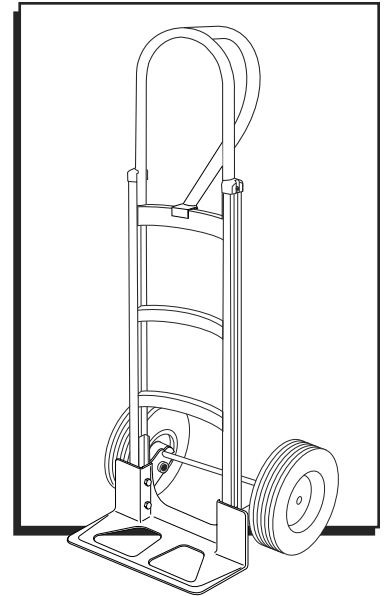

PARTS

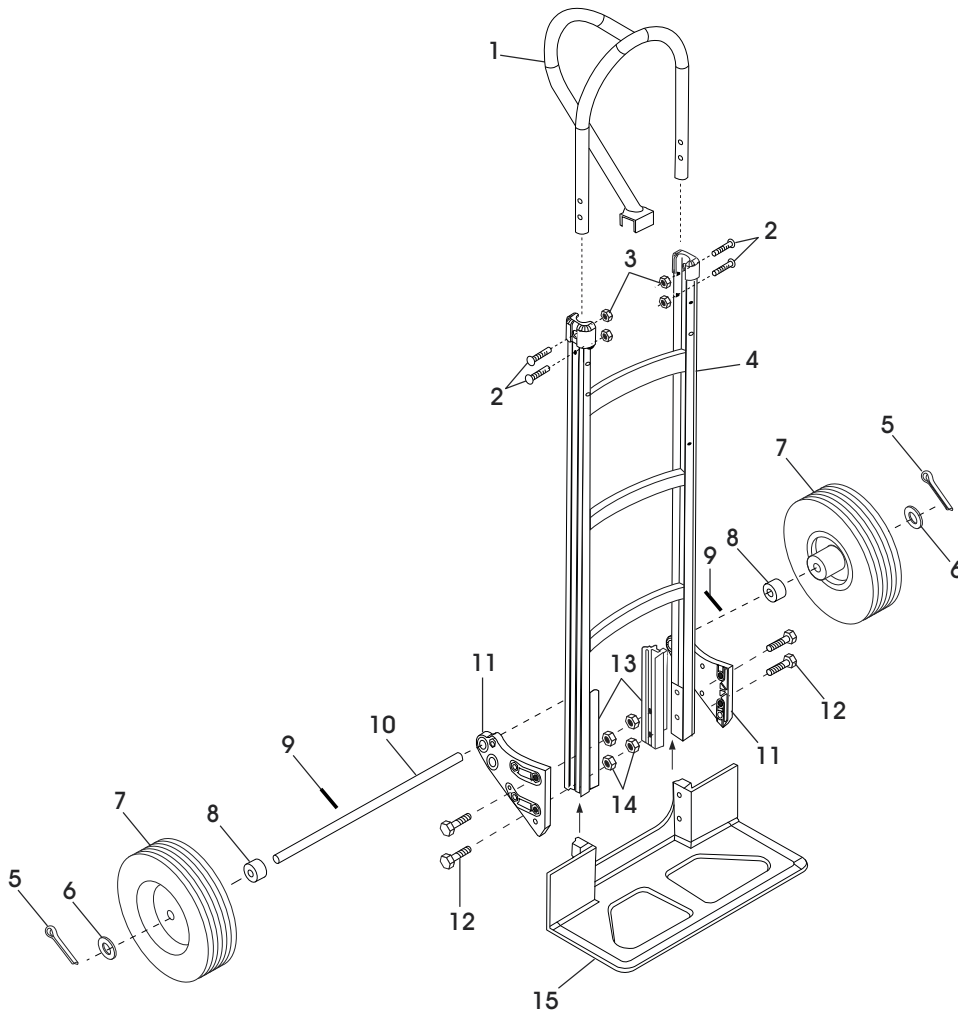

REF.	QTY.	DESCRIPTION
1	1	Handle
2	4	6mm Bolt
3	4	6mm Locknut
4	1	Frame
5	2	Cotter Pin
6	2	Washer
7	2	Wheel
8	2	Spacer
9	2	Round Pin
10	1	Axle
11	2	Axle Support
12	4	8mm Bolt
13	2	Frame Reinforcement
14	4	8mm Locknut
15	1	Nose Plate

ASSEMBLY

 **NOTE:** Do not use air or power tools.

ATTACH HANDLE

1. Slide handle into the top rails of frame. Align holes in handle and frame. Insert four 6mm bolts through the frame and handle and secure with locknuts. (See Figure 1)

ATTACH NOSE PLATE AND AXLE SUPPORTS

1. Position frame reinforcements against bottom frame rail. (See Figure 2a) Slide nose plate into channel on frame reinforcement, keeping bolt holes aligned. (See Figure 2)
2. Align axle supports with outside rail of frame. (See Figure 2)
3. Insert four 8mm bolts through the axle supports, frame, frame reinforcements and nose plate. Secure with locknuts, but **DO NOT** tighten. (See Figure 2)

ATTACH AXLE AND WHEELS

1. Lay hand truck on front so axle supports face upwards. (See Figure 3)
2. Insert axle through holes in axle supports. Align holes in axle with grooves on inside of the axle supports. Use a hammer to tap in the round pins. (See Figure 3a)
3. Slide a spacer onto each end of the axle. Slide a wheel onto each end of the axle. Slide a washer onto each end of the axle. (See Figure 4)
4. Insert a cotter pin through the holes in each end of the axle. Bend cotter pins using pliers to secure wheels. Wheels should spin freely. (See Figure 4)
5. Tighten all locknuts.

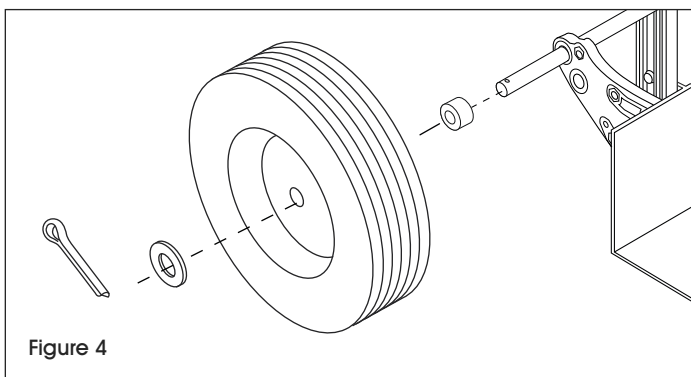
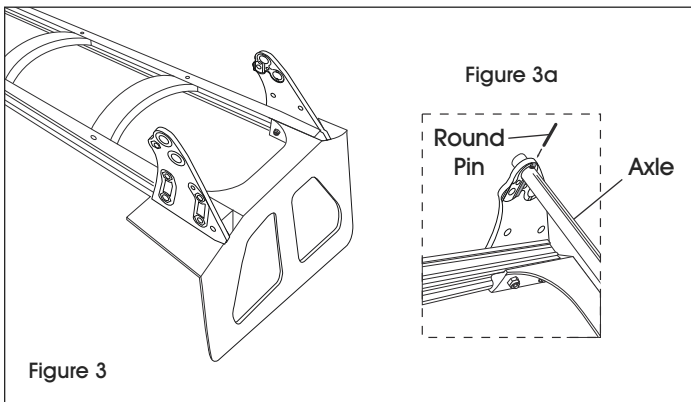
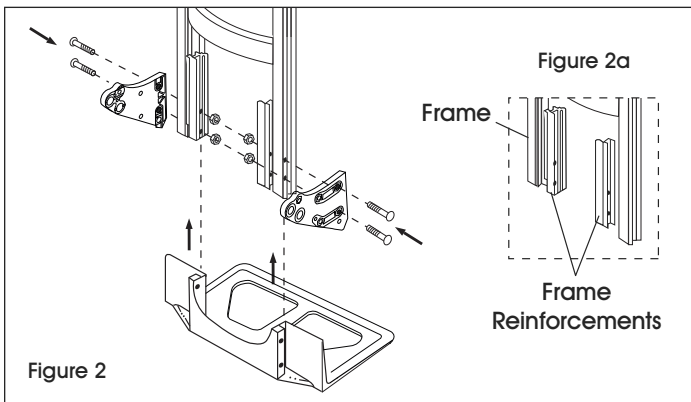
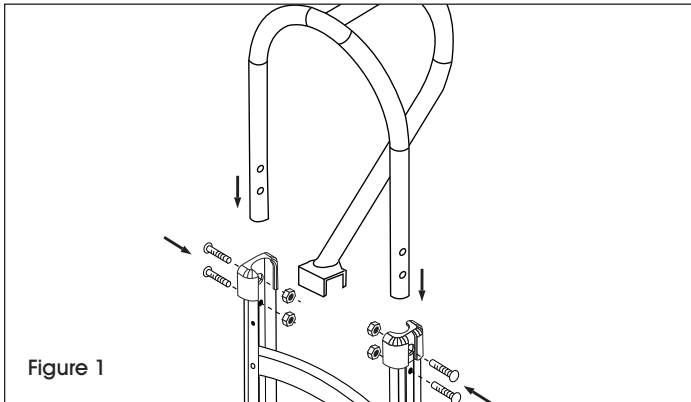

ULINE H-5534

**DIABLITO PARA BARRILES
CON LLANTAS DE CAUCHO SÓLIDO**

800-295-5510

uline.mx

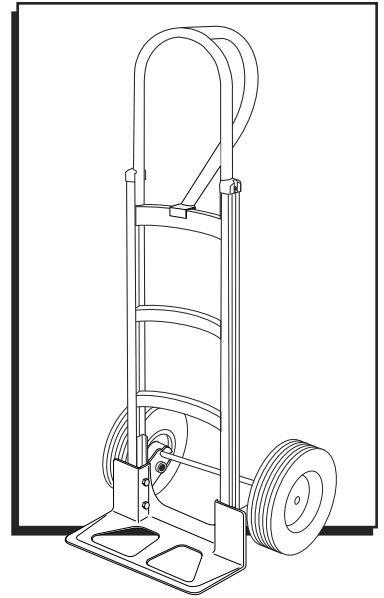

HERRAMIENTAS NECESARIAS



Llave Allen de 6 mm



Llave de 13 mm

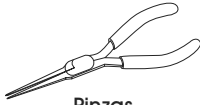

Pinzas

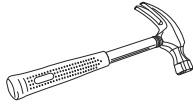

Martillo

PARTES

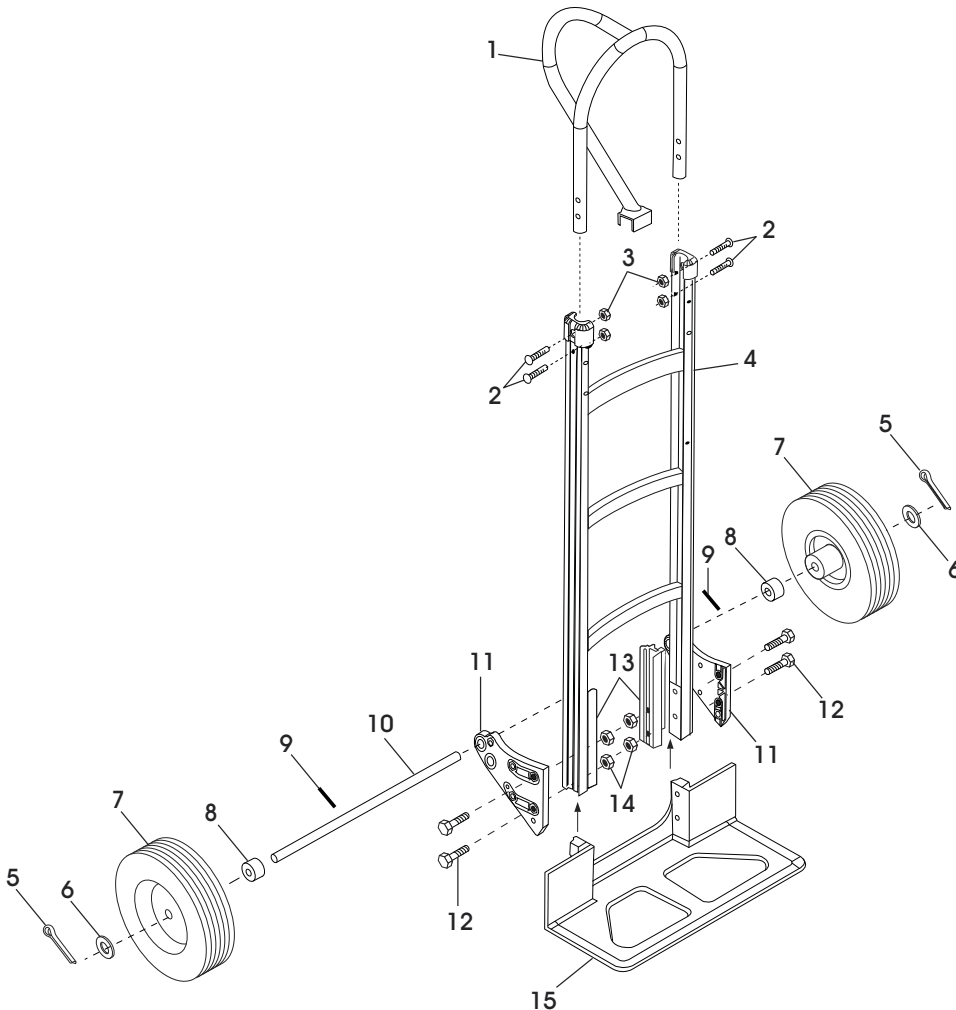

REF.	CANT.	DESCRIPCIÓN
1	1	Asa
2	4	Perno de 6 mm
3	4	Tuerca de Seguridad de 6 mm
4	1	Armazón
5	2	Pasador de Chaveta
6	2	Rondana
7	2	Llanta
8	2	Separador
9	2	Pasador Redondo
10	1	Eje
11	2	Soporte del Eje
12	4	Perno de 8 mm
13	2	Refuerzo del Armazón
14	4	Tuerca de Seguridad de 8 mm
15	1	Base

ENSAMBLE



NOTA: No use herramientas eléctricas ni neumáticas.

FIJE EL ASA

1. Deslice el asa en los rieles superiores del armazón. Alinee los orificios en el asa y el armazón. Inserte cuatro pernos de 6 mm a través del armazón y el asa y fíjelos con tuercas de seguridad. (Vea Diagrama 1)

FIJE LA BASE Y LOS SOPORTES DEL EJE

1. Coloque los refuerzos del armazón contra el fondo del riel del armazón. (Vea Diagrama 2a) Deslice la base en el canal de los refuerzos del armazón, manteniendo alineados los orificios de los pernos. (Vea Diagrama 2)
2. Alinee los soportes del eje con el riel exterior del armazón. (Vea Diagrama 2)
3. Inserte cuatro pernos de 8 mm a través de los soportes del eje, el armazón, los refuerzos del armazón y la base. Asegure con tuercas de seguridad pero NO apriete. (Vea Diagrama 2)

FIJE EL EJE Y LAS LLANTAS

1. Apoye el diablito sobre su parte delantera de forma que los soportes del eje apunten hacia arriba. (Vea Diagrama 3)
2. Inserte el eje a través de los orificios en los soportes del eje. Alinee los orificios del eje con las muescas de la parte interior de los soportes del eje. Use un martillo para introducir los pasadores redondos. (Vea Diagrama 3a)
3. Deslice un separador en cada extremo del eje. Deslice una llanta en cada extremo del eje. Deslice una rondana en cada extremo del eje. (Vea Diagrama 4)
4. Inserte un pasador de chaveta a través de los orificios en cada extremo del eje. Doble los pasadores de chaveta usando unas pinzas para asegurar las llantas. Las llantas deben girar libremente. (Vea Diagrama 4)
5. Apriete todas las tuercas de seguridad.

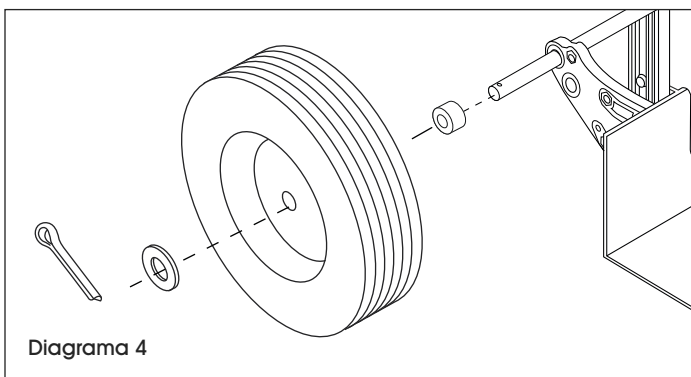
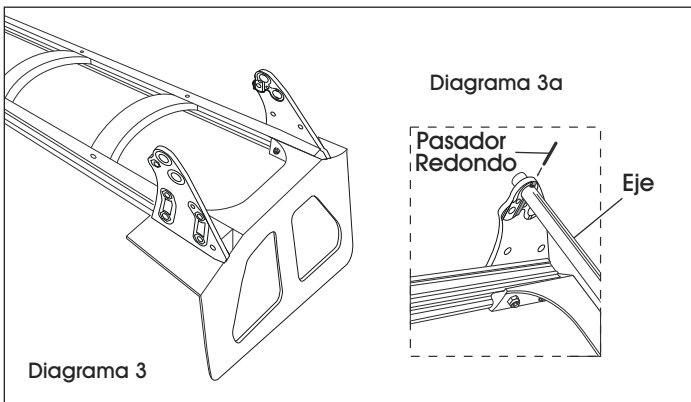
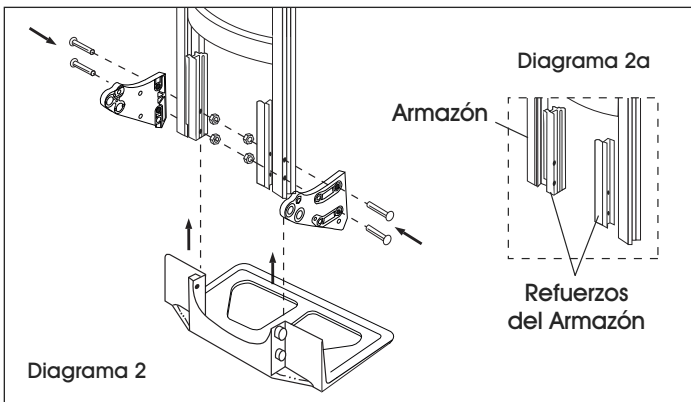
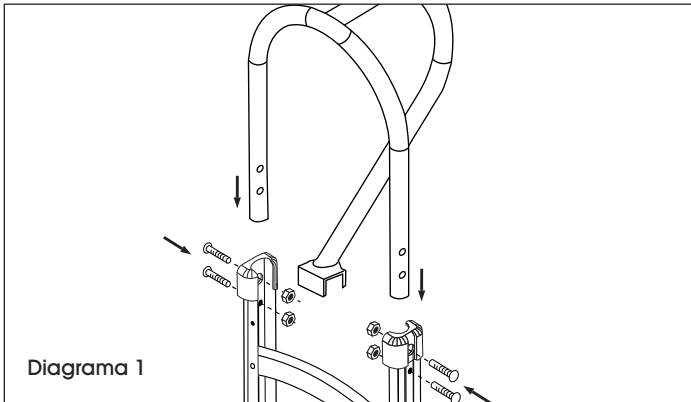

ULINE H-5534

DIABLE DE MANUTENTION POUR BARILS

AVEC ROUES EN CAOUTCHOUC PLEIN

1-800-295-5510

uline.ca

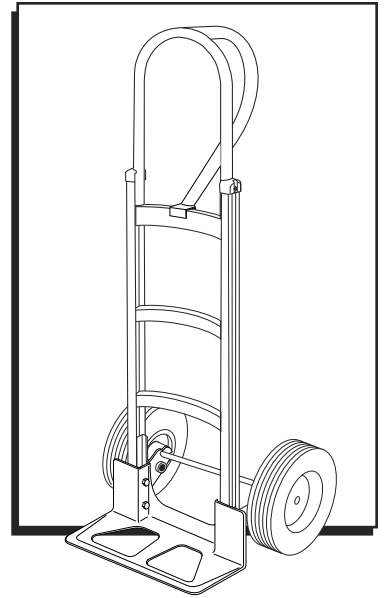

OUTILS REQUIS



Clé Allen de 6 mm

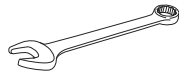

Clé de 13 mm

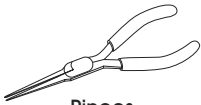

Pinces

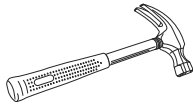

Marteau

PIÈCES

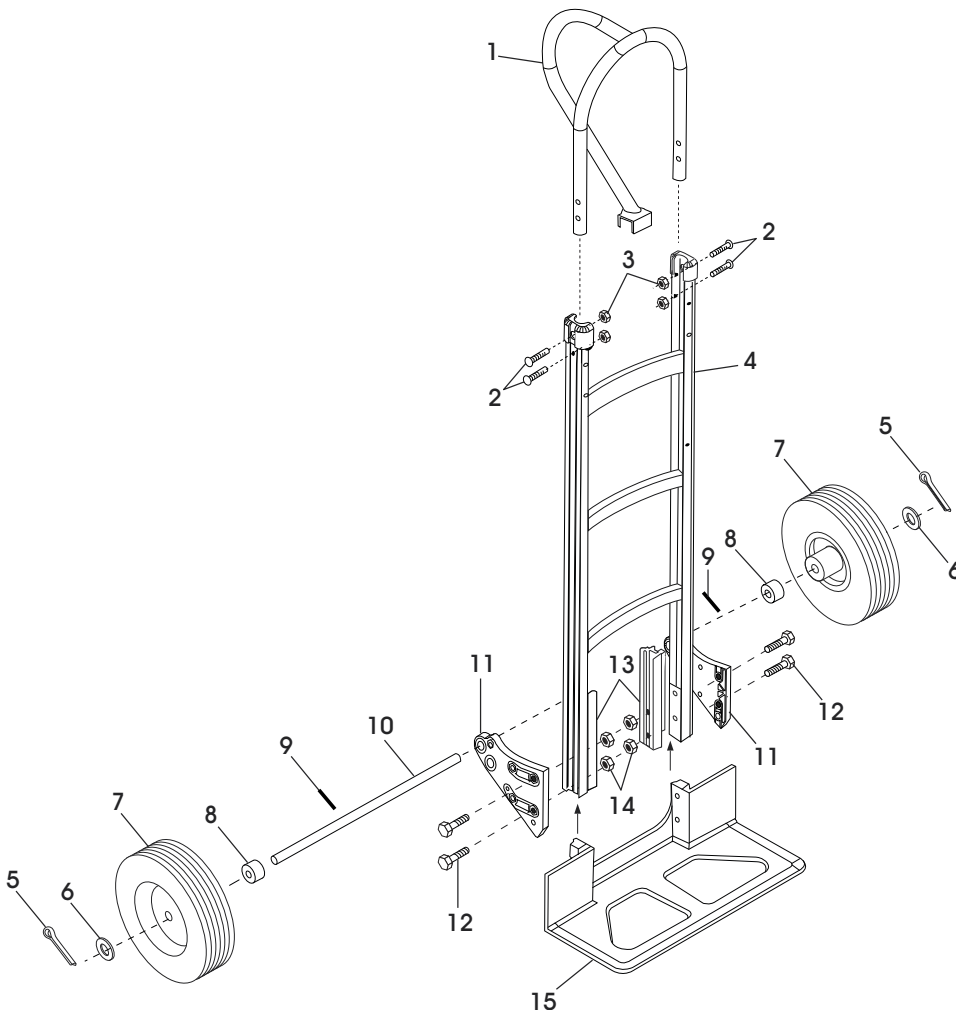

#	QTÉ	DESCRIPTION
1	1	Poignée
2	4	Boulon de 6 mm
3	4	Écrou freiné de 6 mm
4	1	Cadre
5	2	Goupille fendue
6	2	Rondelle
7	2	Roue
8	2	Entretoise
9	2	Goupille
10	1	Essieu
11	2	Support d'essieu
12	4	Boulon de 8 mm
13	2	Renfort de cadre
14	4	Écrou freiné de 8 mm
15	1	Bavette

MONTAGE



REMARQUE : N'utilisez pas d'outils pneumatiques ou électriques.

FIXATION DE LA POIGNÉE

1. Insérez la poignée dans les glissières à l'extrémité supérieure du cadre. Alignez les trous de la poignée et du cadre. Insérez quatre boulons de 6 mm à travers le cadre et la poignée et fixez-les à l'aide des écrous freinés. (Voir Figure 1)

FIXATION DE LA BAVETTE ET DES SUPPORTS D'ESSIEU

1. Positionnez les renforts de cadre contre les glissières à l'extrémité inférieure du cadre. (Voir Figure 2a) Glissez la bavette dans la cannelure des renforts de cadre en gardant les trous de boulon alignés. (Voir Figure 2)
2. Alignez les supports d'essieu avec la glissière extérieure du cadre. (Voir Figure 2)
3. Insérez quatre boulons de 8 mm à travers les supports d'essieu, le cadre, les renforts de cadre et la bavette. Fixez avec les écrous freinés, mais NE serrez PAS. (Voir Figure 2)

FIXATION DE L'ESSIEU ET DES ROUES

1. Posez le diable vers l'avant de sorte que les supports d'essieu soient orientés vers le haut. (Voir Figure 3)
2. Enfilez l'essieu dans les trous des supports d'essieu. Alignez les trous dans l'essieu avec les rainures à l'intérieur des supports d'essieu. Utilisez un marteau pour planter les goupilles. (Voir Figure 3a)
3. Enfilez une entretoise à chaque extrémité de l'essieu. Enfilez une roue à chaque extrémité de l'essieu. Enfilez une rondelle à chaque extrémité de l'essieu. (Voir Figure 4)
4. Insérez une goupille fendue dans le trou à chaque extrémité de l'essieu. Repliez les goupilles à l'aide de pinces afin de fixer les roues en place. Les roues doivent tourner librement. (Voir Figure 4)
5. Serrez tous les écrous freinés.

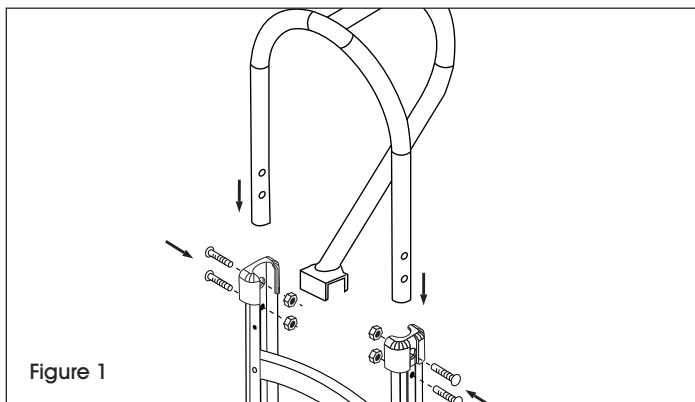

Figure 1

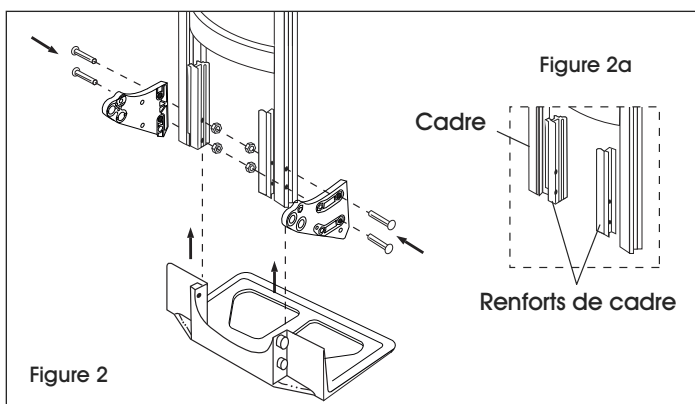

Figure 2

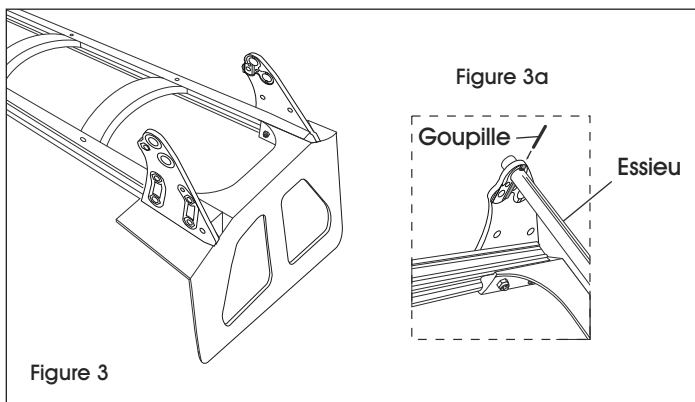

Figure 3

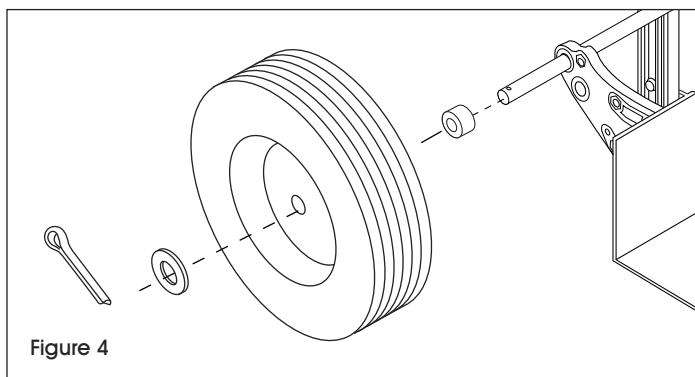

Figure 4

ULINE CHICAGO • ATLANTA • DALLAS • LOS ANGELES • MINNEAPOLIS • NYC/PHILA • SEATTLE • MEXICO • CANADA

1-800-295-5510

uline.ca