



H-4068, H-4069, H-4072
H-5012, H-5013, H-5014
H-5015, H-5016, H-5017

1-800-295-5510
uline.com

GRAVITY ROLLER CONVEYORS

TOOL NEEDED



9/16" (14mm) Wrench

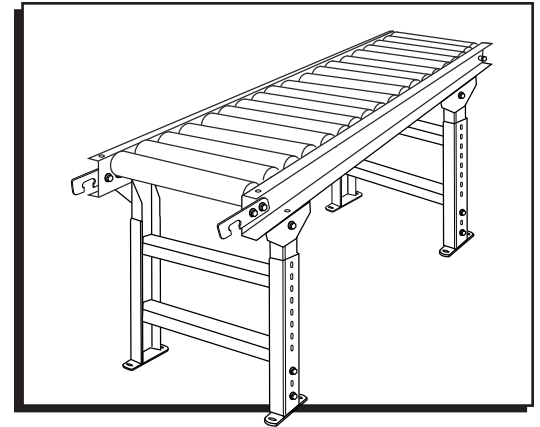

ASSEMBLY INSTRUCTIONS

BOLTING CONVEYOR FRAME(S) TO H-STAND LEG SUPPORTS



NOTE: H-Stands are sold separately. Hardware included: 4 hex head bolts, 4 flange nuts.

1. Hardware is prescrewed into the tops of the H-Stands. Remove the hardware. (See Figure 1)

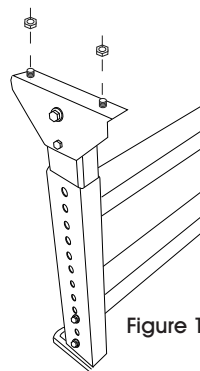

Figure 1

2. **Bolting two H-Stands to one conveyor frame:** Position H-Stands on the end of the conveyor frame. Fasten bolts through conveyor and H-Stand. (See Figure 2)

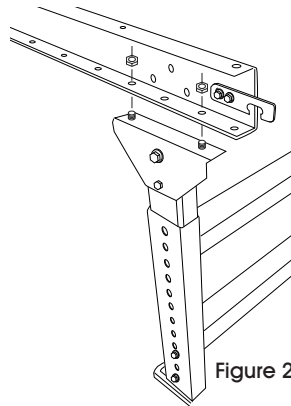

Figure 2

Bolting a single H-Stand to two conveyor frames: Position the H-Stand halfway between the end of two conveyor frames, lining up one hole on each conveyor with the H-Stand. Fasten bolts through conveyors and H-Stand. (See Figure 3)

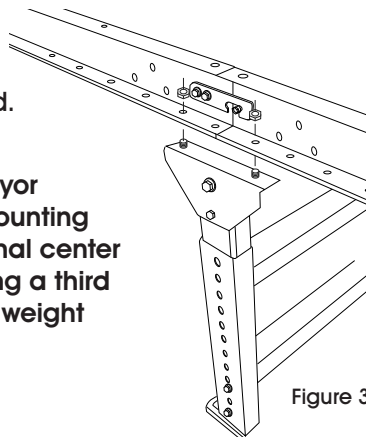

Figure 3



NOTE: Each conveyor frame includes mounting holes for an optional center leg support. Adding a third support increases weight capacity.

CONNECTING MULTIPLE CONVEYOR FRAMES TOGETHER

1. Lift the hook over the bolt to keep it in place. (See Figure 4).

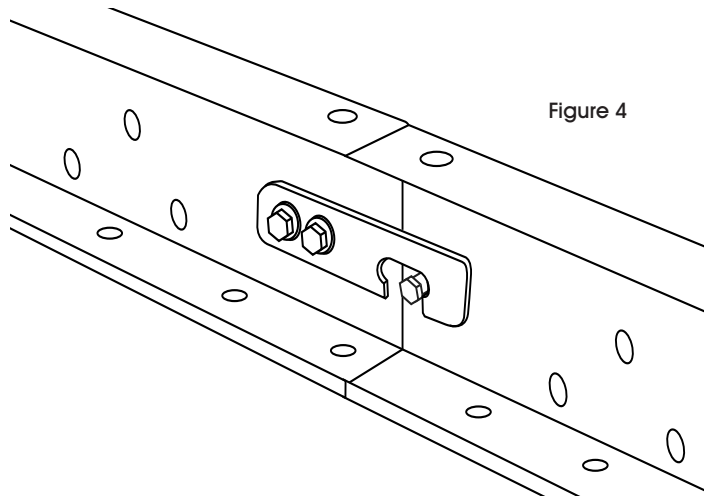

Figure 4

BANDAS TRANSPORTADORAS DE RODILLOS POR GRAVEDAD

HERRAMIENTA NECESARIA



Llave de 14 mm (9/16")

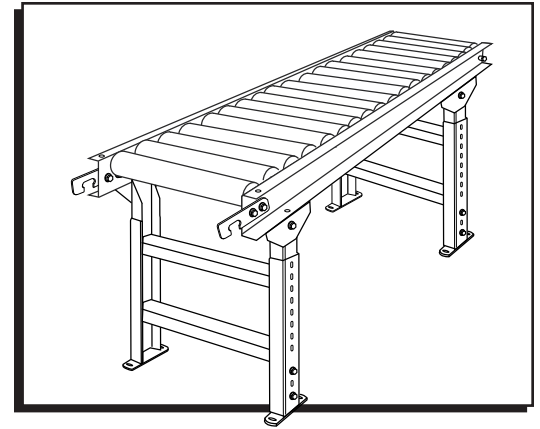

INSTRUCCIONES DE ENSAMBLE

ATORNILLE MARCOS DE LA BANDA TRANSPORTADORA A SOPORTE(S) EN H



NOTA: Soportes en H se venden por separado. Tornillería incluye: 4 pernos de cabeza hexagonal, 4 tuercas con borde.

1. La tornillería está preatornillada en la parte superior de los Soportes en H. Retire la tornillería. (Vea Diagrama 1)
2. **Atornille dos Soportes en H a un marco de la transportadora:** Posicione el Soporte en H en el extremo del marco de la transportadora. Apriete los pernos a través de la transportadora y los Soportes en H. (Vea Diagrama 2)

Atornille un sólo Soporte en H a dos marcos de transportadora: Posicione el Soporte en H a la mitad entre los extremos de dos marcos de transportadora, alinee un orificio en cada transportadora con el Soporte en H. Apriete los pernos a través de las transportadoras y el Soporte en H. (Vea Diagrama 3)



NOTA: Cada marco de transportadora incluye orificios para instalación para una pata de soporte opcional. Agregar el tercer soporte incrementa la capacidad de peso.



Diagrama 1



Diagrama 2

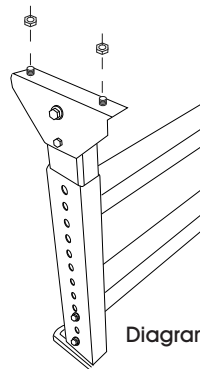

Diagrama 3

CONECTE MÚLTIPLES MARCOS DE TRANSPORTADORA JUNTOS

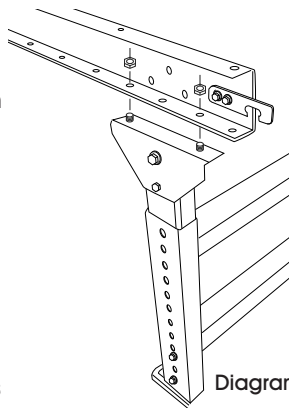
1. Levante el gancho sobre el perno para mantenerlo en su lugar. (Vea Diagrama 4)

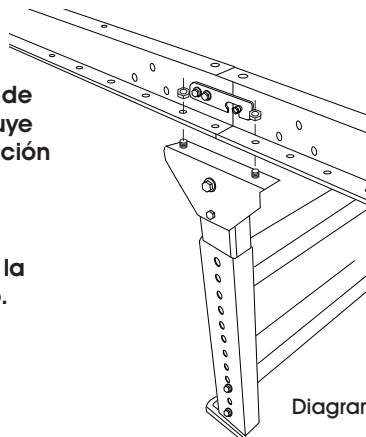

Diagrama 4

ULINEH-4068, H-4069, H-4072
H-5012, H-5013, H-5014
H-5015, H-5016, H-50171-800-295-5510
uline.ca

CONVOYEURS À ROULEAUX LIBRES

OUTIL REQUIS

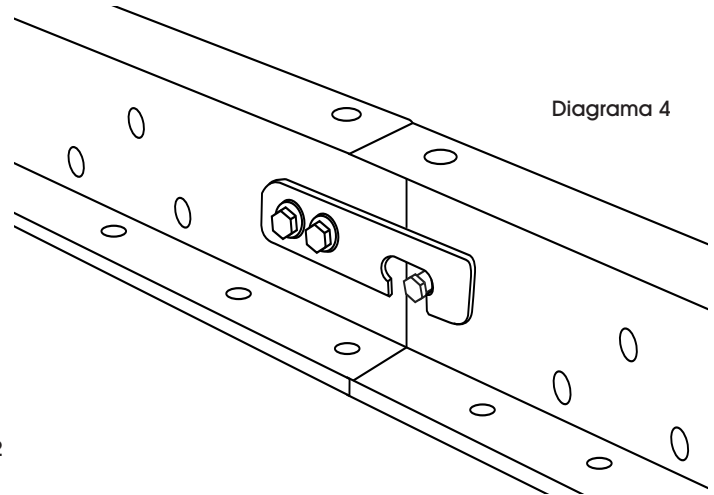
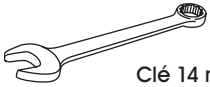

Clé 14 mm (9/16 po)

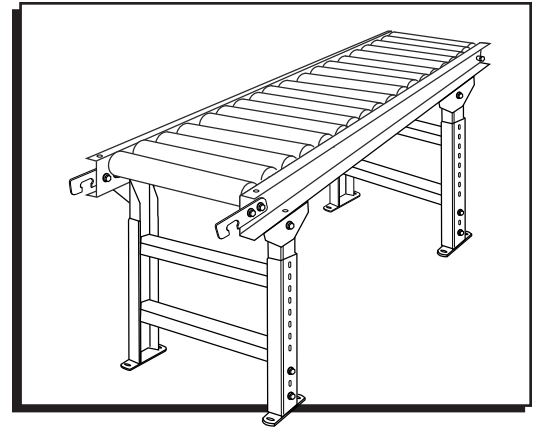

INSTRUCTIONS D'ASSEMBLAGE

BOULONNAGE DU/DES CADRE(S) DE CONVOYEUR AUX JAMBES D'APPUI EN H



REMARQUE : Jambes d'appui en H vendues séparément. Quincaillerie incluse : 4 boulons à tête hexagonale, 4 écrous à épaulement.

1. La quincaillerie est déjà vissée dans la partie supérieure des jambes d'appui en H. Retirez la quincaillerie. (Voir Figure 1)

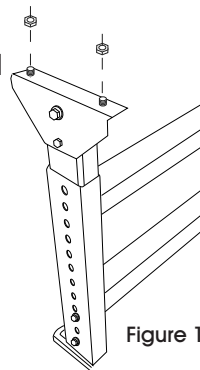

Figure 1

2. Boulonnage de deux jambes d'appui en H à un cadre de convoyeur : Positionnez les jambes d'appui en H à l'extrémité du cadre de convoyeur. Fixez les boulons traversant le convoyeur et la jambe d'appui en H. (Voir Figure 2)

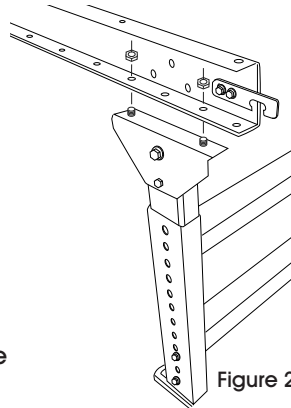

Figure 2

Boulonnage d'une seule jambe d'appui en H à deux cadres de convoyeur : Positionnez la jambe d'appui en H sous la jonction des extrémités des deux cadres de convoyeur, en alignant un trou de chaque convoyeur avec la jambe d'appui en H. Fixez les boulons traversant les convoyeurs et la jambe d'appui en H. (Voir Figure 3)

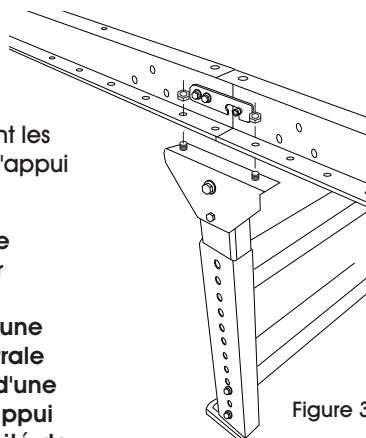

Figure 3



REMARQUE : Chaque cadre de convoyeur possède des trous d'assemblage pour une jambe d'appui centrale optionnelle. L'ajout d'une troisième jambe d'appui augmente la capacité de poids.

RACCORDEMENT ENSEMBLE DE PLUSIEURS CADRES DE CONVOYEUR

1. Soulevez le crochet au-dessus du boulon afin de le maintenir en position. (Voir Figure 4)

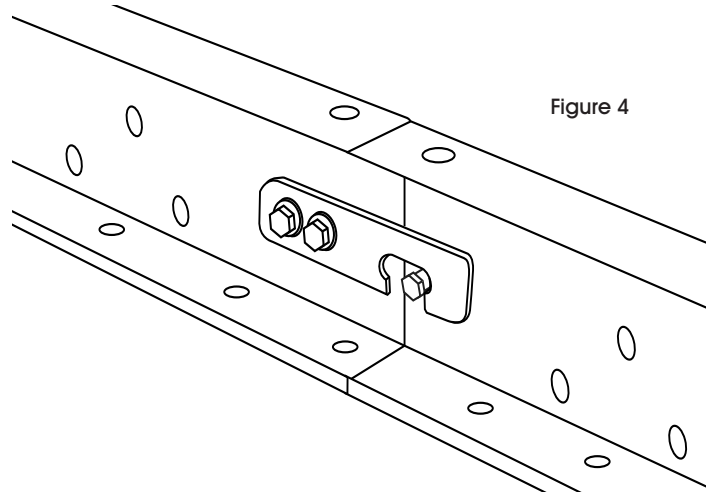

Figure 4