

# ULINE H-3065

## 12" WORKING TABLE

1-800-295-5510  
uline.com

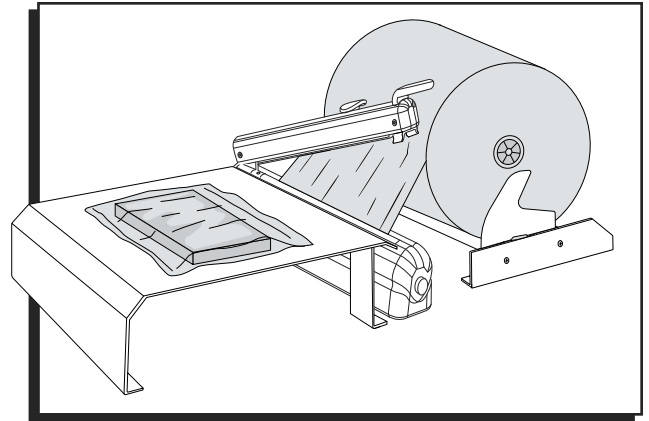

### ASSEMBLY

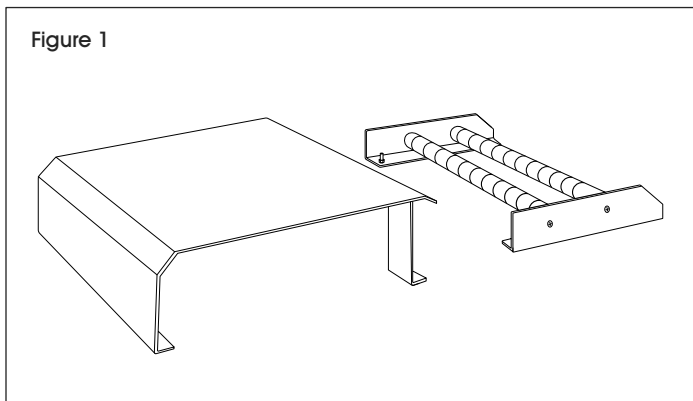

1. Remove working table kit from box. (See Figure 1)

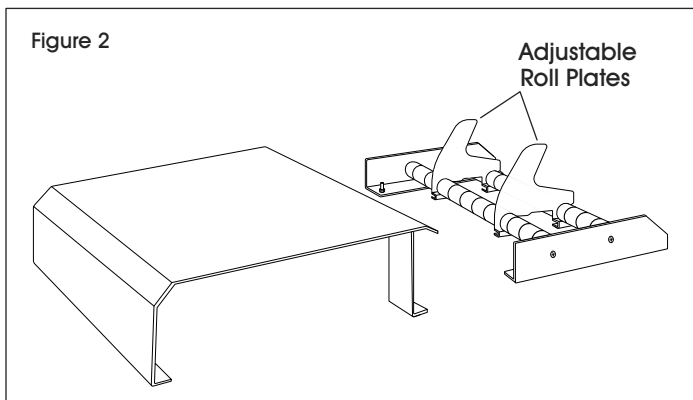

2. Insert the included adjustable roll plates between roller grooves to help hold roll in place. (See Figure 2)

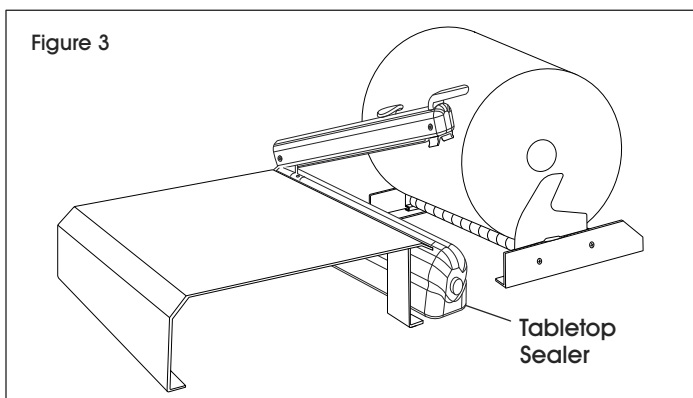

3. Place tabletop sealer between the working table and roller bar to begin production. (See Figure 3)

**ULINE** H-3065  
**MESA DE TRABAJO  
DE 12"**

800-295-5510  
uline.mx

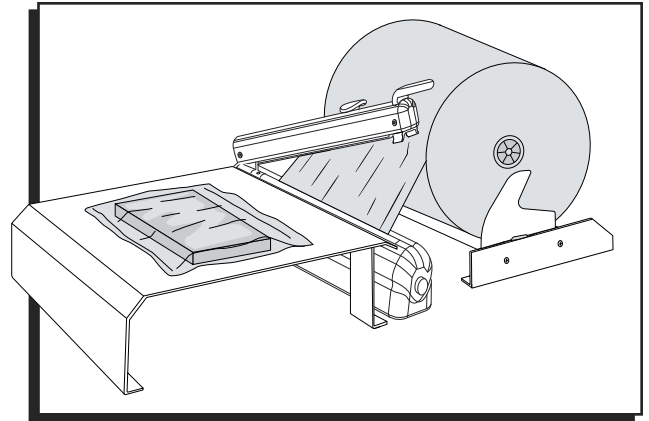

**ENSAMBLE**

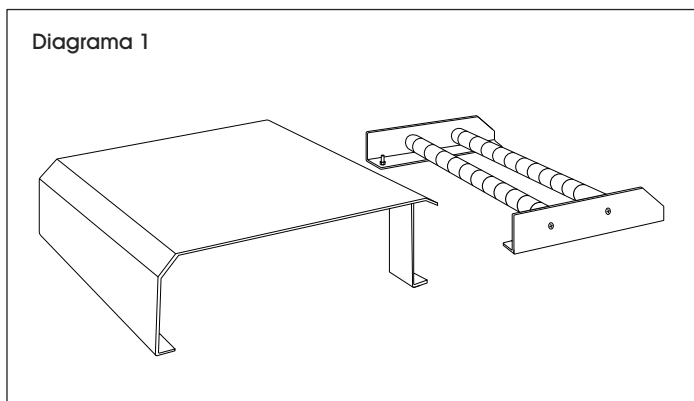

1. Saque de la caja el kit de la mesa de trabajo. (Vea Diagrama 1)

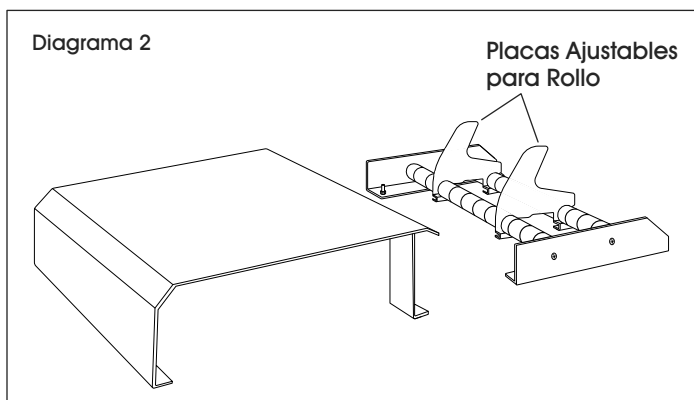

2. Inserte las placas ajustables para rollo incluidas entre las ranuras de los rodillos para ayudar a mantener el rollo en su lugar. (Vea Diagrama 2)

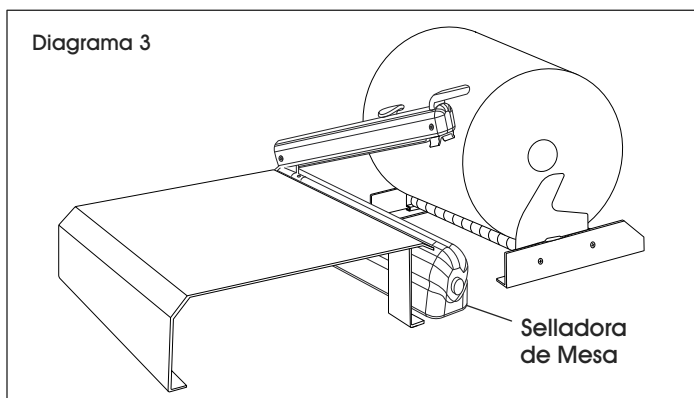

3. Coloque la selladora de mesa entre la mesa de trabajo y la barra del rodillo para comenzar la producción. (Vea Diagrama 3)

**ULINE** H-3065  
**TABLE DE TRAVAIL –**  
**12 PO**

1-800-295-5510  
uline.ca

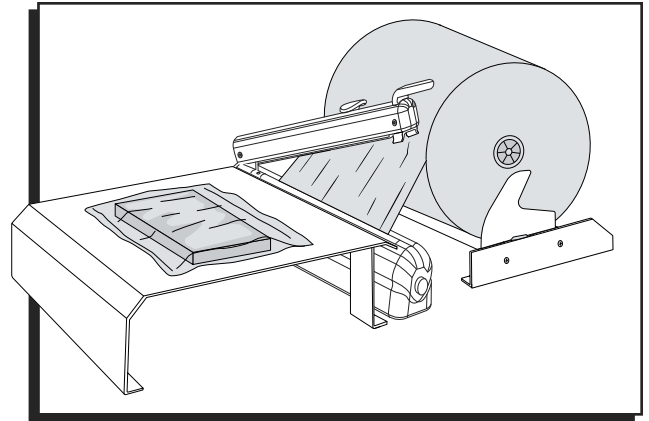

## MONTAGE

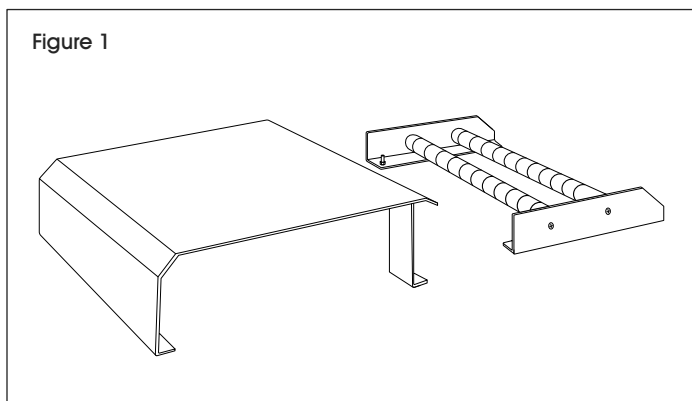

1. Retirez l'ensemble de la table de travail de la boîte. (Voir Figure 1)

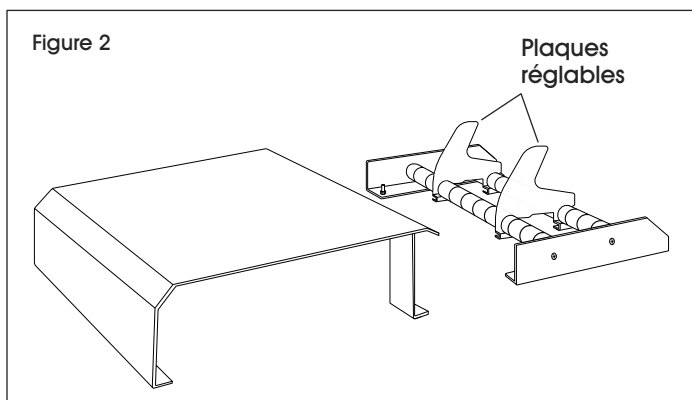

2. Insérez les plaques réglables incluses entre les rainures des cylindres du support pour aider à maintenir le rouleau en place. (Voir Figure 2)

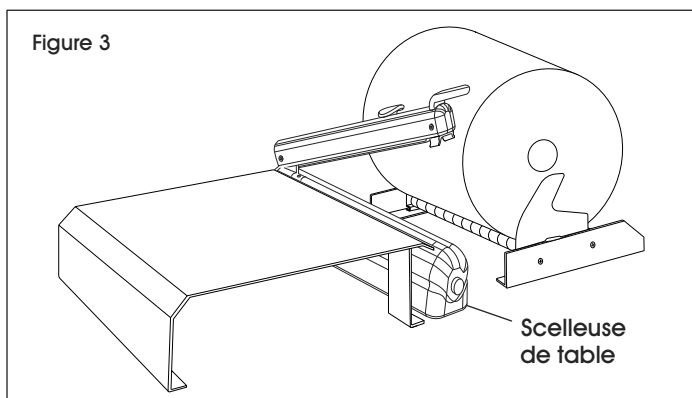

3. Placez la scelleuse de table entre la table de travail et le support à rouleau pour commencer le travail. (Voir Figure 3)