

ULINE H-3012 PLASTIC AND FIBER DRUM TRUCK

1-800-295-5510
uline.com

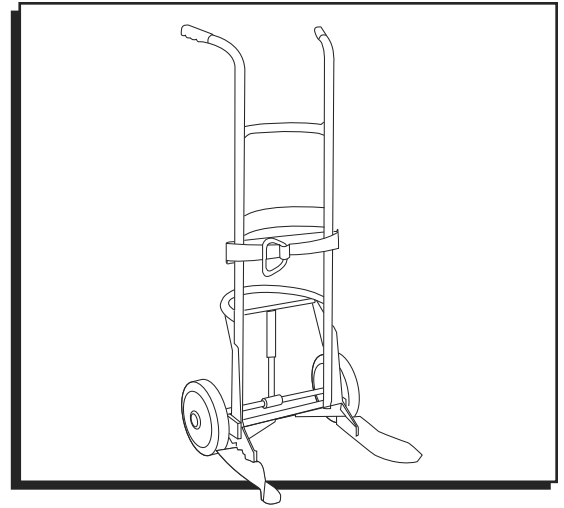

OPERATION



WARNING! Read all instructions before using this truck.

1. Position truck with both nose pads in contact with bottom edge of drum. (See Figure 1)

Figure 1

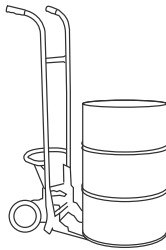

2. Wrap belt around drum and place in fork grooves, if existing. (See Figure 2)

Figure 2

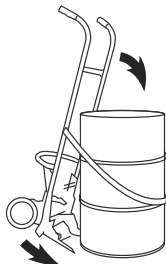

 **NOTE:** Make sure belt is not twisted.

3. Tighten belt so that truck frame touches upper part of drum. (See Figure 3)

Figure 3

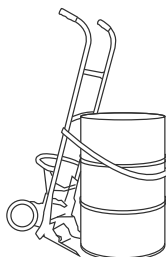

4. Pull truck back carefully just until drum rests on nose pads, then re-tighten belt. (See Figure 4)

Figure 4

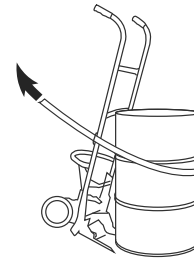

5. You are now ready to transport the drum. (See Figure 5)

Figure 5

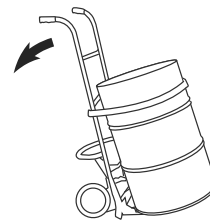

NOTE: With heavier drums, place foot on backrest for better leverage.



CAUTION! 1,000 lb/454kg MAXIMUM CAPACITY.

- DO NOT OVERLOAD.
- DO NOT USE WITHOUT BELT.
- USE ON LEVEL SURFACES ONLY.
- DO NOT USE ON STAIRS OR RAMPS.



CAUTION! Make sure drum rests securely on nose pads before moving. When unloading, be sure to hold truck securely when loosening belt.

ULINE H-3012

DIABLITO PARA TAMBOS DE PLÁSTICO Y FIBRA

800-295-5510
uline.mx

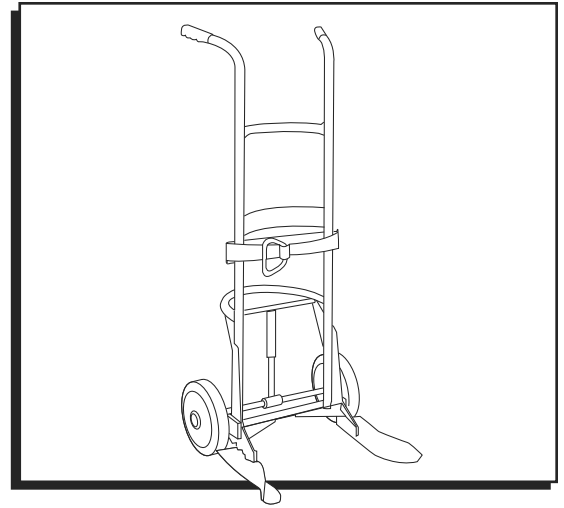

FUNCIONAMIENTO



¡ADVERTENCIA! Lea todas las instrucciones antes de usar este diablito.

1. Coloque el diablito con ambas abrazaderas en contacto con el borde inferior del tambor. (Vea Diagrama 1)

Diagrama 1

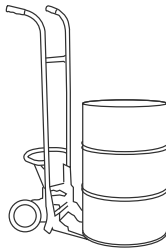

2. Enrolle la correa alrededor del tambor y colóquela en las ranuras de las horquillas, si las hay. (Vea Diagrama 2)

Diagrama 2

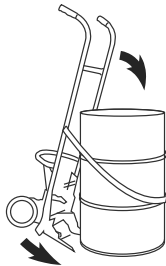

NOTA: Asegúrese de que la correa no esté retorcida.

3. Apriete la correa de forma que la estructura del diablito toque la parte superior del tambor. (Vea Diagrama 3)

Diagrama 3

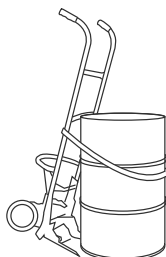

4. Estire del diablito ligeramente hacia atrás justo hasta que el tambor se apoye sobre las abrazaderas y vuelva a apretar la correa. (Vea Diagrama 4)

Diagrama 4

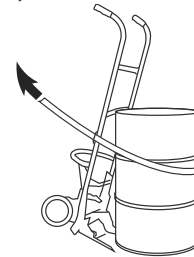

5. A partir de este punto puede comenzar a transportar el tambor. (Vea Diagrama 5)

Diagrama 5

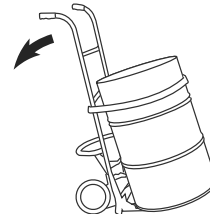

NOTA: En el caso de tambos más pesados, coloque el pie en el respaldo para mayor apalancamiento.



¡PRECAUCIÓN! CAPACIDAD MÁXIMA DE 454 kg/1,000 lbs.

- NO SOBRECARGAR.
- NO USAR SIN LA CORREA.
- USAR SOLO EN SUPERFICIES NIVELADAS.
- NO USAR EN ESCALERAS O RAMPAS.

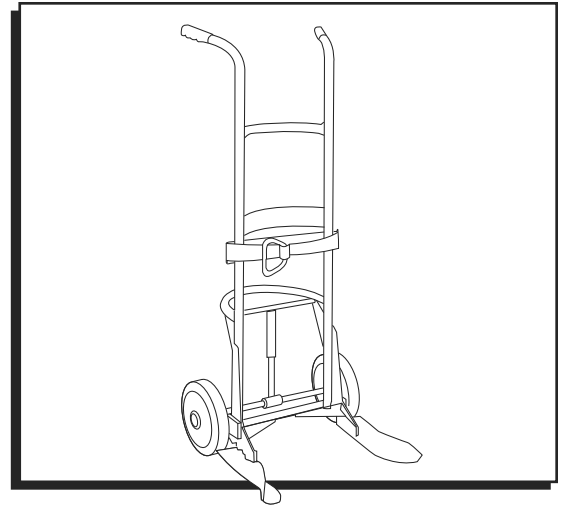

¡PRECAUCIÓN! Asegúrese de que el tambor descansa de forma segura sobre las abrazaderas antes de moverlo. Al descargarlo, asegúrese de sostener el tambor de manera segura cuando afloje la correa.

**FONCTIONNEMENT**

AVERTISSEMENT! Lisez toutes les instructions avant d'utiliser ce diable.

1. Placez le diable de façon à ce que les deux bavettes soient en contact avec le bord inférieur du baril. (Voir Figure 1)

Figure 1

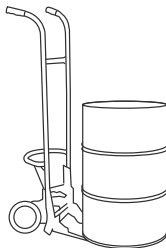

2. Enroulez la courroie autour du baril et placez-la dans les rainures de fourche, le cas échéant. (Voir Figure 2)

Figure 2



-  **REMARQUE :** Assurez-vous que la courroie n'est pas entortillée.

3. Serrez la courroie de façon à ce que le cadre du diable soit en contact avec la partie supérieure du baril. (Voir Figure 3)

Figure 3



4. Tirez le diable délicatement jusqu'à ce que le baril repose sur les bavettes, puis resserrez la courroie. (Voir Figure 4)

Figure 4

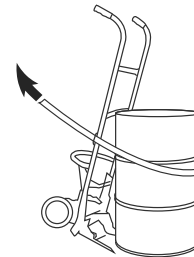

5. Votre diable est maintenant prêt à transporter le baril. (Voir Figure 5)

Figure 5

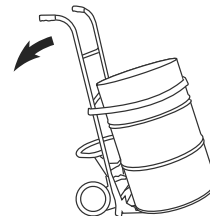

REMARQUE : Pour les barils plus lourds, placez votre pied sur le dossier pour un meilleur effet de levier.



MISE EN GARDE! CAPACITÉ MAXIMALE :
1 000 lb/454 kg.

- NE PAS SURCHARGER.
- NE PAS UTILISER SANS COURROIE.
- UTILISER SUR DES SURFACES PLANES SEULEMENT.
- NE PAS UTILISER DANS DES ESCALIERS OU SUR DES RAMPES.



MISE EN GARDE! Assurez-vous que le baril repose solidement sur les bavettes avant de déplacer le diable. Lors du déchargement, assurez-vous de tenir le diable fermement au moment de desserrer la courroie.