

ULINE H-2599 LITTLE RED CART

1-800-295-5510
uline.com

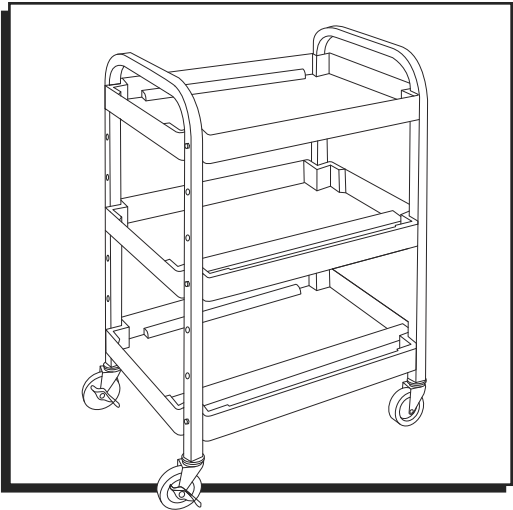

TOOLS NEEDED



Allen Wrench
(Included)

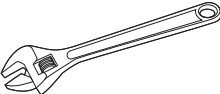

Adjustable Wrench

PARTS

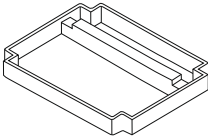

Shelf x 3



Tubular Frame x 2



Swivel Caster with Brake x 2



Swivel Caster x 2



L-Bracket x 12

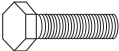

Hex Head Bolt x 12



Washer x 12



Screw x 4



Lock Washer x 4



Spacer x 4



Nut x 12

ASSEMBLY

1. Lay one tubular frame flat. Align shelf with holes in frame at desired height. (See Figure 1)

2. Insert hex head bolt and washer through outside of tubular frame and shelf. Repeat for remaining side. (See Figure 2)

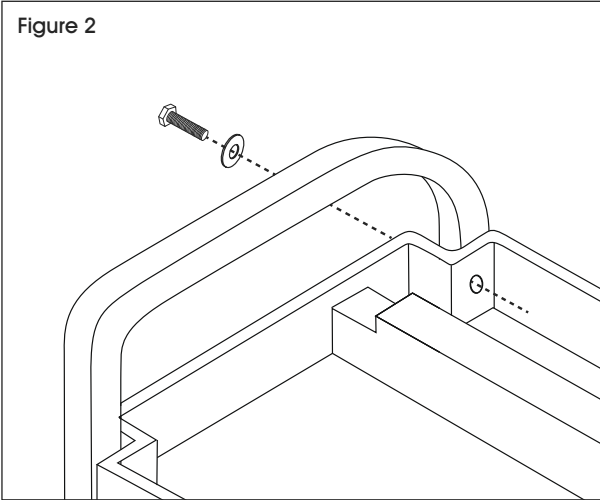
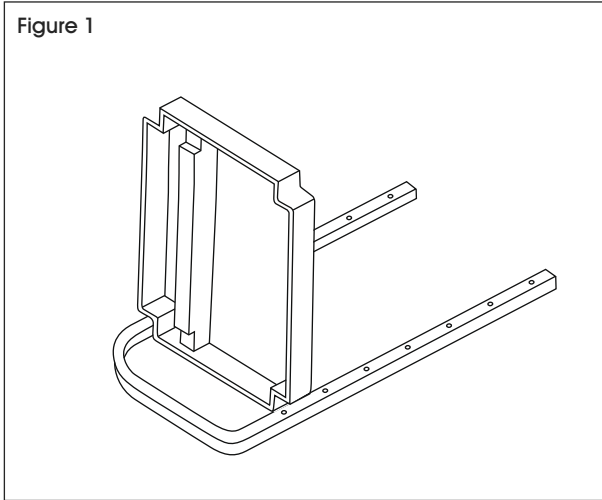

ASSEMBLY CONTINUED

- Place L-bracket and nut on inside of shelf and over hex head bolt. Tighten with wrench. Repeat for remaining side. (See Figure 3)

 **NOTE:** Do not fully tighten nuts and bolts.

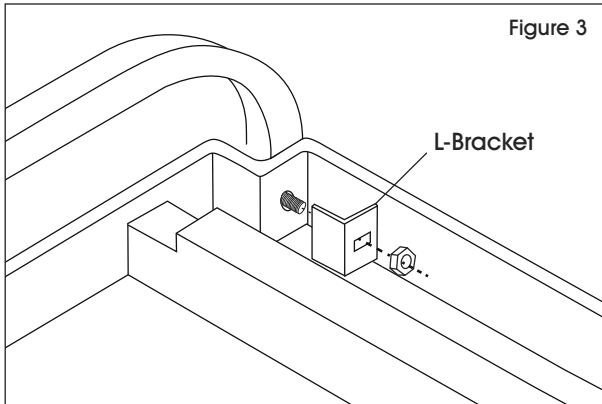

- Repeat steps 1-3 for additional shelves and remaining tubular frame on opposite end of shelves.
- Once all shelves are installed, tighten all nuts and bolts.
- Place spacers over caster stems and insert stems into bottom of tubular frame. (See Figure 4)

 **NOTE:** Attach swivel casters with brake on same end of cart.

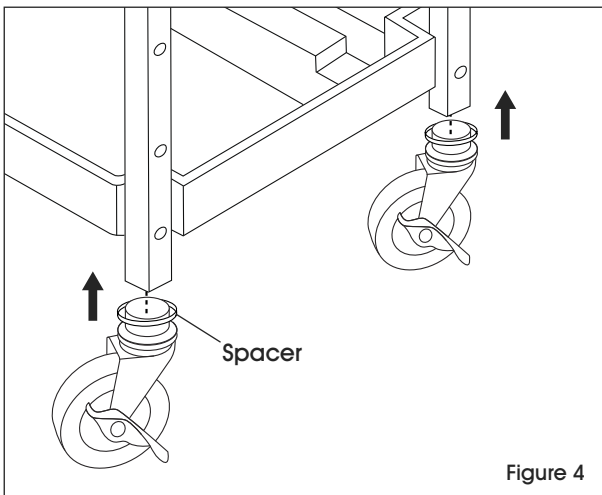

- While holding caster in place, insert lock washer and screw into bottom hole on tubular frame. Tighten with Allen wrench. Repeat for remaining casters. (See Figure 5)

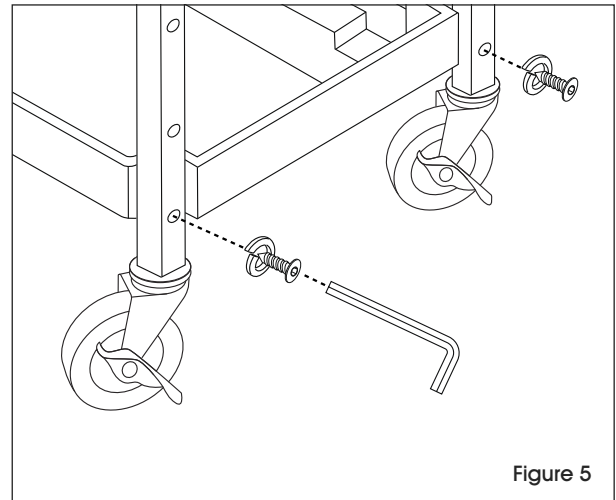

ULINE

1-800-295-5510
uline.com

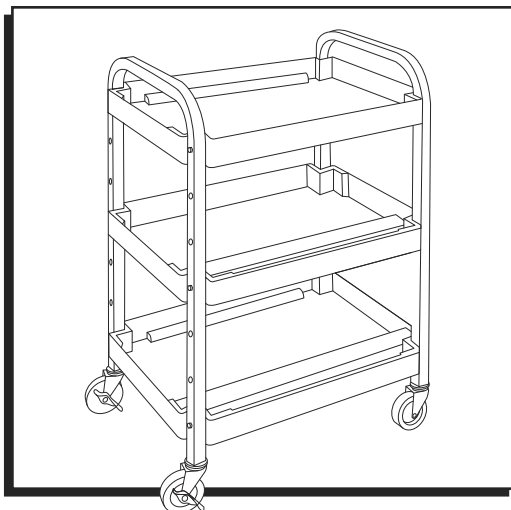

HERRAMIENTAS NECESARIAS



Llave Allen
(Incluida)

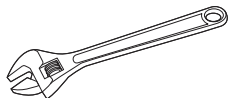

Llave Inglesa

PARTES

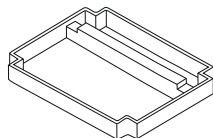

3 Repisas

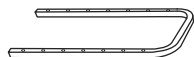

2 Armazones Tubulares



2 Ruedas Giratorias
con Freno



2 Ruedas Giratorias



12 Soportes en L

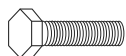

12 Pernos de
Cabeza Hexagonal



12 Rondanas



4 Tornillos



4 Rondanas de
Seguridad



4 Separadores



12 Tuercas

ENSAMBLE

1. Coloque un armazón tubular sobre una superficie plana. Alinee la repisa con los orificios del armazón a la altura deseada. (Vea Diagrama 1)

Diagrama 1

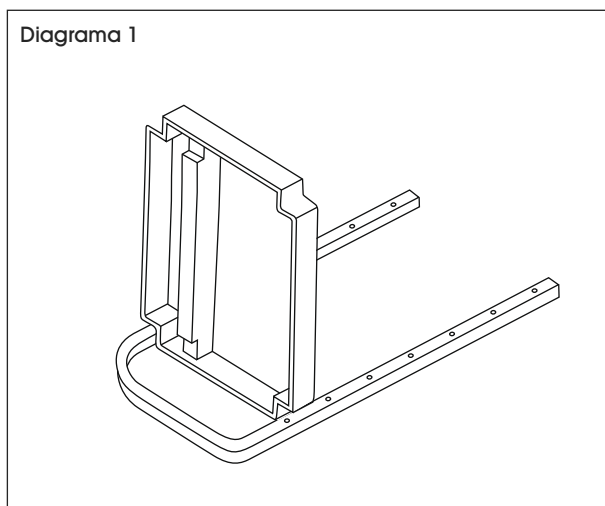

2. Inserte el perno de cabeza hexagonal a través de la parte exterior del armazón tubular y la repisa. Repita la operación en el lado restante. (Vea Diagrama 2)

Diagrama 2

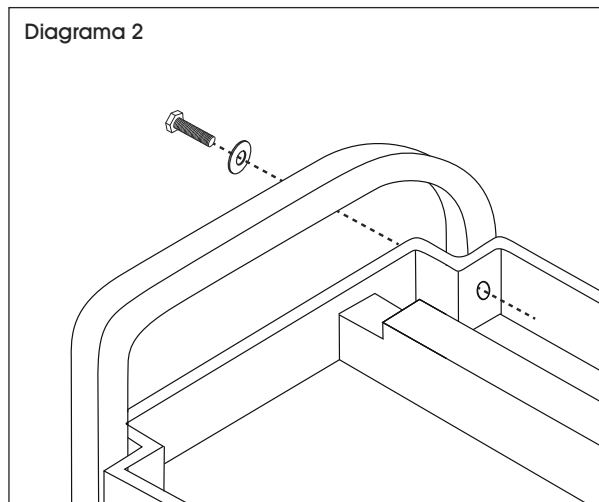

CONTINUACIÓN DEL ENSAMBLE

3. Coloque el soporte en L y la tuerca en la parte interior de la repisa y encima del perno de cabeza hexagonal. Apriete con una llave. Repita la operación en el lado restante. (Vea Diagrama 3)

 **NOTA:** No apriete por completo las tuercas y los pernos.

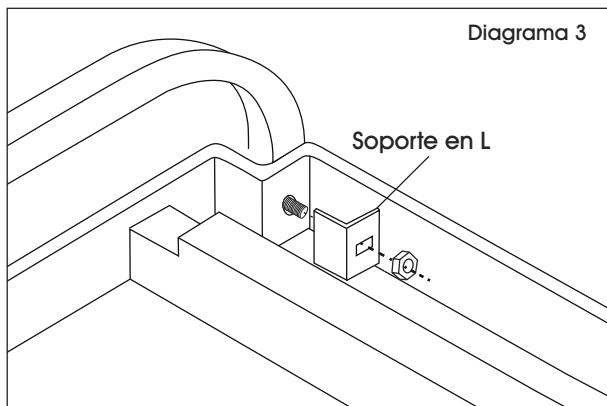

4. Repita los pasos 1-3 con las repisas adicionales y el armazón tubular restante en el lado opuesto de las repisas.
5. Una vez todas las repisas estén instaladas, apriete todas las tuercas y pernos.
6. Coloque los separadores sobre los vástagos de las ruedas e inserte los vástagos en la parte inferior del armazón tubular. (Vea Diagrama 4)

 **NOTA:** Fije las ruedas giratorias con freno en el mismo extremo del carrito.

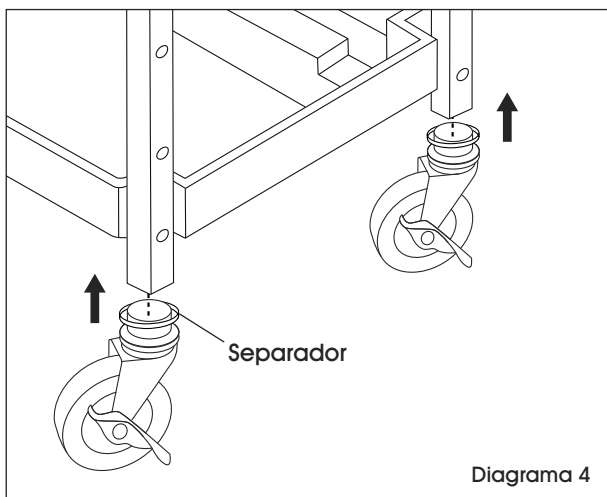

7. Mientras sostiene la rueda en su lugar, inserte la rondana de seguridad y el tornillo en el orificio inferior del armazón tubular. Apriete con la llave Allen. Repita el proceso para las ruedas restantes. (Vea Diagrama 5)

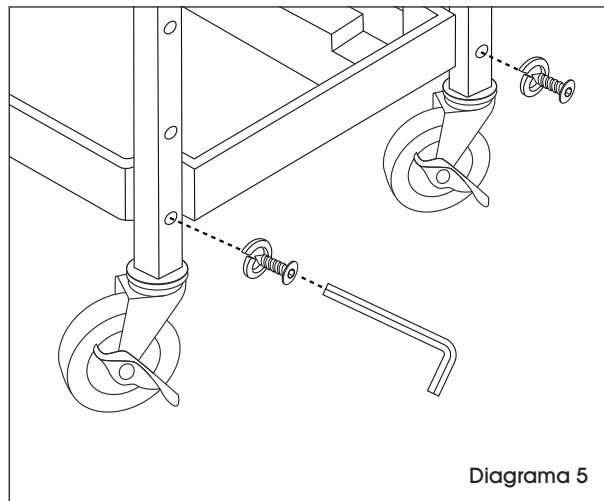

ULINE

800-295-5510
uline.mx

ULINE H-2599

PETIT CHARIOT ROUGE

1-800-295-5510
uline.ca

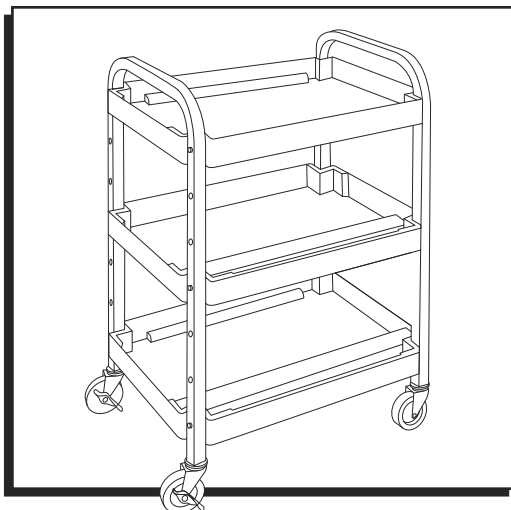

OUTILS REQUIS



Clé Allen
(inclus)

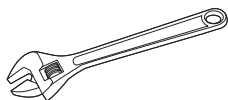

Clé à molette

PIÈCES

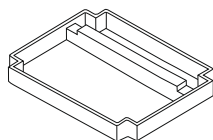

Tablette x 3



Cadre tubulaire x 2



Roulette pivotante
avec frein x 2



Roulette
pivotante x 2



Support en L x 12

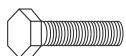

Boulon à tête
hexagonale x 12



Rondelle x 12



Vis x 4



Rondelle de blocage x 4



Espaceur x 4



Écrou x 12

MONTAGE

1. Posez un cadre tubulaire à plat. Alignez la tablette sur les trous du cadre à la hauteur souhaitée. (Voir Figure 1)

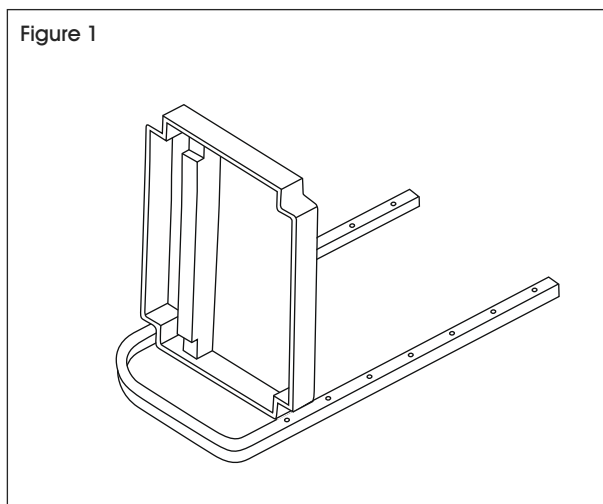

2. Insérez un boulon à tête hexagonale et une rondelle à travers l'extérieur du cadre tubulaire, puis à travers la tablette. Répétez la procédure pour l'autre côté. (Voir Figure 2)

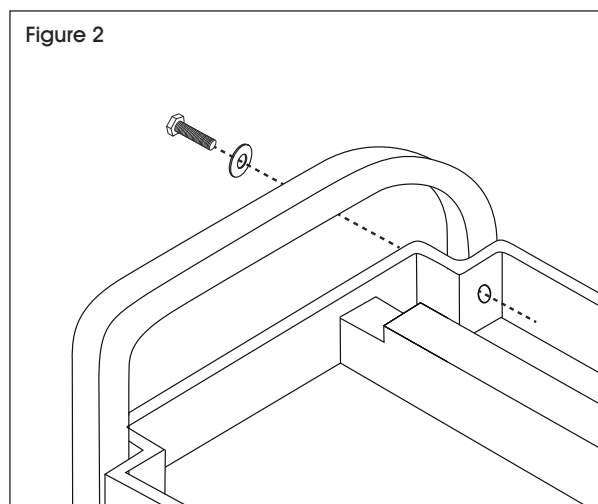

MONTAGE SUITE

- Placez un support en L et un écrou sur le boulon à tête hexagonale depuis l'intérieur de la tablette. Serrez avec une clé. Répétez la procédure pour l'autre côté. (Voir Figure 3)

 **REMARQUE :** Ne serrez pas complètement les écrous et les boulons.

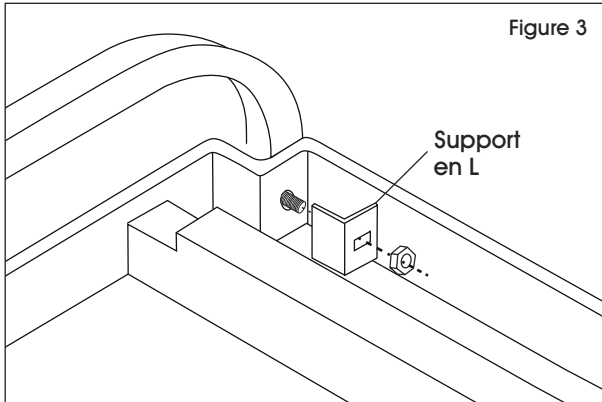

- Répétez les étapes 1 à 3 pour les autres tablettes et la partie restante du cadre tubulaire sur le côté opposé des tablettes.
- Une fois que toutes les tablettes sont installées, serrez tous les écrous et les boulons.
- Placez un espaceur sur la tige de chaque roulette, puis insérez les tiges dans le bas du cadre tubulaire. (Voir Figure 4)

 **REMARQUE :** Fixez les roulettes pivotantes avec frein sur la même extrémité du chariot.

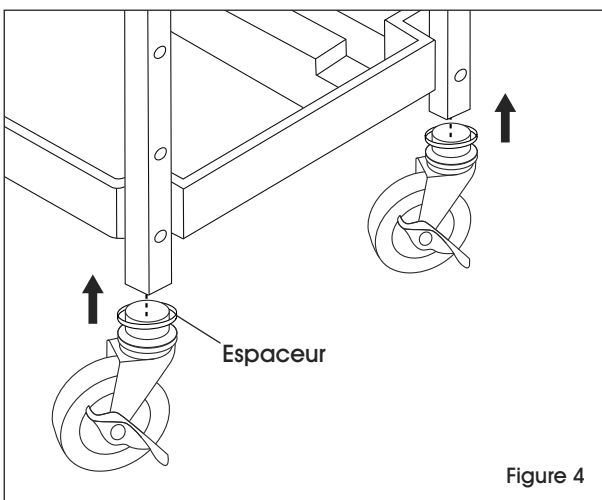

- Tout en maintenant la roulette en place, insérez une rondelle de blocage et une vis dans le trou inférieur du cadre tubulaire. Serrez le tout avec la clé Allen. Répétez l'opération pour les roulettes restantes. (Voir Figure 5)

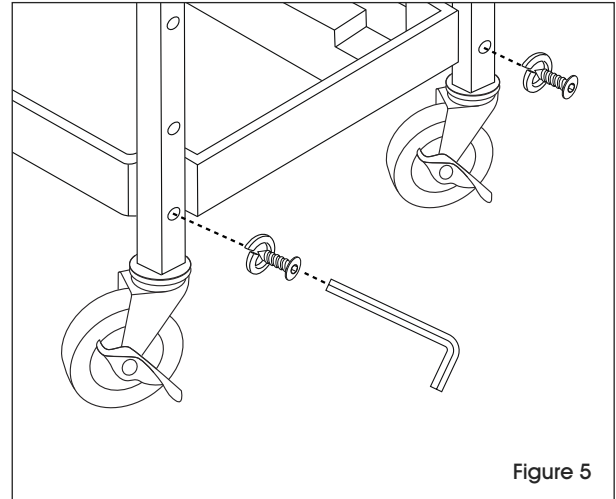

ULINE

1-800-295-5510
uline.ca