

# ULINE H-2273 PAPER DISPENSER

1-800-295-5510  
uline.com

Para Español, vea páginas 3-4.  
Pour le français, consulter les pages 5-6.

## TOOLS NEEDED



Drill



Drill Bit

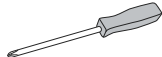

Phillips Screwdriver

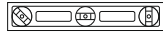

Level

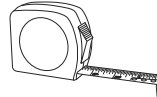

Tape Measure

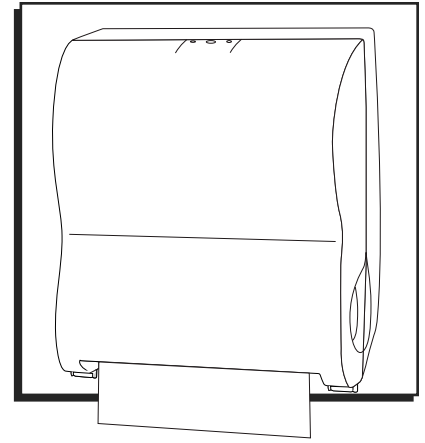

## PARTS



Anchor x 4

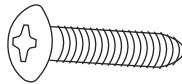

Screw x 4



Snap-In Key x 1

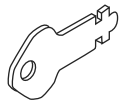

Standard Key x 1

## MOUNTING

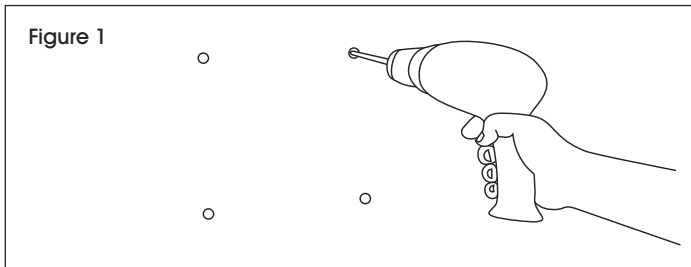

1. Open dispenser cover completely by using either standard key or snap-in key. Hold dispenser to ideal mounting place on wall.
2. Mark the four holes on the wall where screws will be inserted.
3. Set dispenser aside and drill into wall at four marked locations with an appropriate drill bit. (See Figure 1)
4. Hold dispenser to wall so that the holes in the wall and the dispenser match up. Insert four screws into previously drilled holes.



**NOTE:** Recommended placement is 54" from the floor to the bottom of the dispenser. Allow 12" of clearance below the dispenser to pull paper towel and 4" of clearance on the right side to access knob.

## LOADING

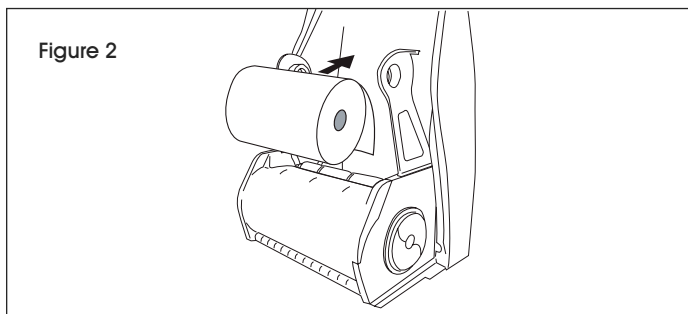

1. Install roll of paper so that it unwinds from the back. (See Figure 2)

## LOADING CONTINUED

Figure 3

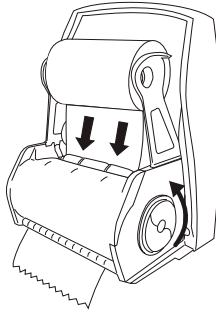

1. Tuck the paper behind and under the white roller. Twist the knob located on the right-hand side until the paper feeds through the clear dispensing module. (See Figure 3)



**NOTE:** Using the blue transfer clips to load a new roll is unnecessary.

## STUB ROLL LOADING

Figure 4

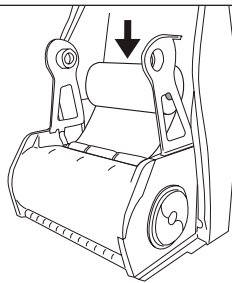

1. Remove the remaining stub roll from the roll support arms without unthreading the paper and place in the stub roll tray at the bottom of the dispenser. (See Figure 4)
2. Place a new roll on the roll support arms with the paper unwinding from the back.

Figure 5

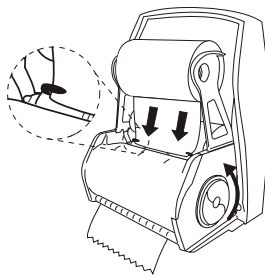

3. Place the end of the new roll of paper under the blue transfer clips. (See Figure 5)
4. When the stub roll is exhausted, a user can start the pre-loaded roll by turning the knob two full turns.

## LOCK AND KEY

- The standard lock with a removable standard key is provided for security.
- If a keyed lock is not required, a snap-in key is provided. The snap-in key is installed by pushing it down firmly into the lock and rocking it slightly until it snaps.

**ULINE**

1-800-295-5510  
uline.com

# ULINE H-2273 DESPACHADOR DE TOALLAS

800-295-5510  
uline.mx

## HERRAMIENTAS NECESARIAS



Taladro



Broca

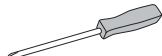

Desarmador  
de Cruz



Nivel

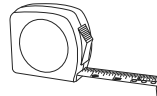

Cinta  
de Medir

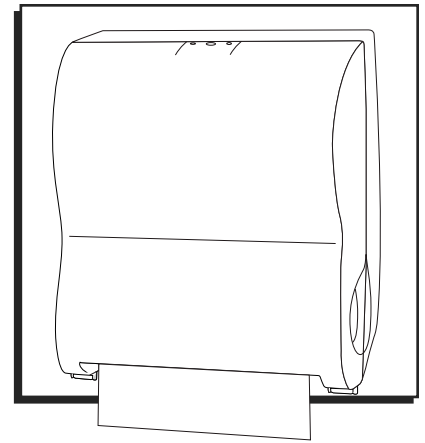

## PARTES



4 Taquetes

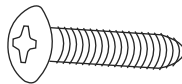

4 Tornillos



1 Llave a Presión

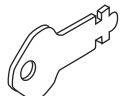

1 Llave Estándar

## INSTALACIÓN

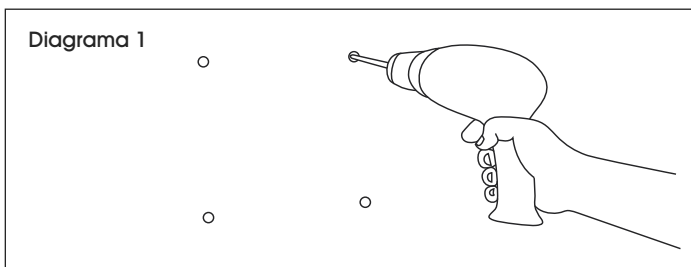

1. Abra la cubierta del despachador por completo usando ya sea la llave estándar o la llave a presión. Sostenga el despachador en la posición ideal para su instalación en la pared.
2. Marque en la pared los cuatro orificios en los que se insertarán los tornillos.
3. Deje a un lado el despachador y taladre la pared en los cuatro lugares marcados con la broca apropiada. (Vea Diagrama 1)
4. Sostenga el despachador contra la pared de forma que los orificios en la pared coincidan con los del despachador. Inserte cuatro tornillos en los orificios que taladró previamente.



**NOTA:** La ubicación recomendada es de 1.37 m (54") del piso a la parte inferior del despachador. Deje despejado un espacio de 30.48 cm (12") debajo del despachador para jalar la toalla de papel y 10 cm (4") del lado derecho para acceder a la perilla.

## CARGA

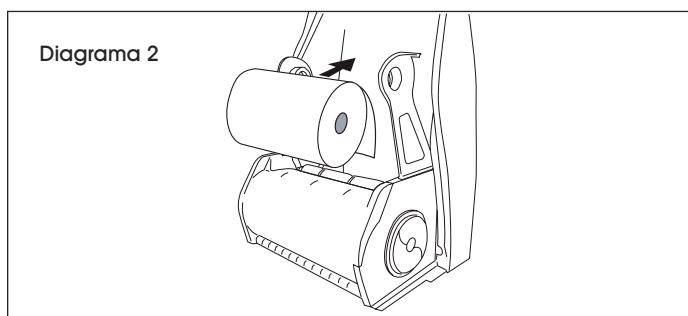

1. Instale el rollo de papel de modo que se desenrolle desde la parte posterior. (Vea Diagrama 2)

## CONTINUACIÓN DE CARGA

Diagrama 3

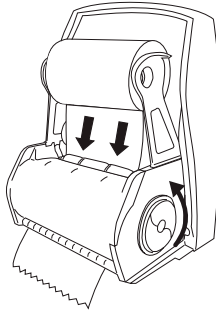

1. Ponga el papel detrás y debajo del rodillo blanco. Gire la perilla ubicada en el lado derecho hasta que el papel pase por el módulo despachador transparente. (Vea Diagrama 3)



**NOTA:** No es necesario usar los clips de transferencia azules para cargar un nuevo rollo.

## CARGA DEL ROLLO AUXILIAR

Diagrama 4

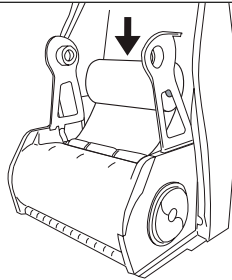

1. Retire el remanente del rollo auxiliar de los brazos de soporte y colóquelo en la bandeja del rollo auxiliar en la parte inferior del despachador. (Vea Diagrama 4)
2. Coloque un nuevo rollo en los brazos de soporte de modo que se desenrolle desde la parte de atrás.

Diagrama 5

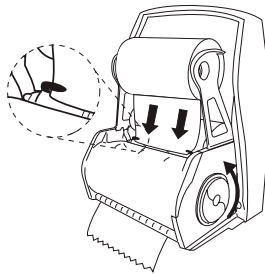

3. Ponga el extremo del nuevo rollo de papel bajo los clips de transferencia azules. (Vea Diagrama 5)
4. Cuando se agote el rollo auxiliar, cualquier usuario puede comenzar el rollo preinstalado dando dos vueltas completas a la perilla.

## CERRADURA Y LLAVE

- La cerradura estándar con llave extraíble estándar son proporcionadas para su seguridad.
- Si no necesita una cerradura con llave, se proporciona una llave a presión. La llave a presión se instala empujándola firmemente en la cerradura y sacudiéndola levemente hasta que haga un clic.

**ULINE**

800-295-5510  
uline.mx

**ULINE** H-2273

# DISTRIBUTEUR DE SERVIETTES

1-800-295-5510

uline.ca

## OUTILS REQUIS



Perceuse



Mèche  
de perceuse

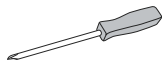

Tournevis  
cruciforme



Niveau à  
bulles

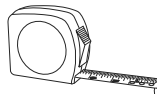

Ruban à  
mesurer

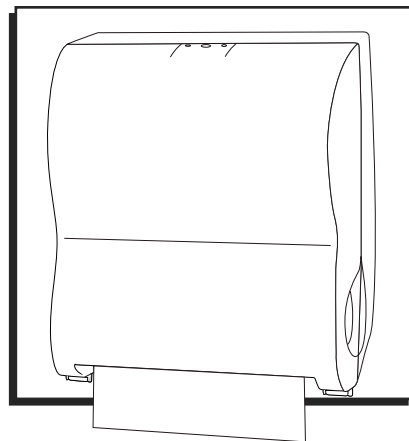

## PIÈCES



Ancrage mural x 4

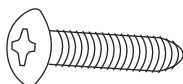

Vis x 4



Clé à enclenchement x 1

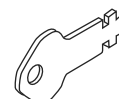

Clé standard x 1

## INSTALLATION

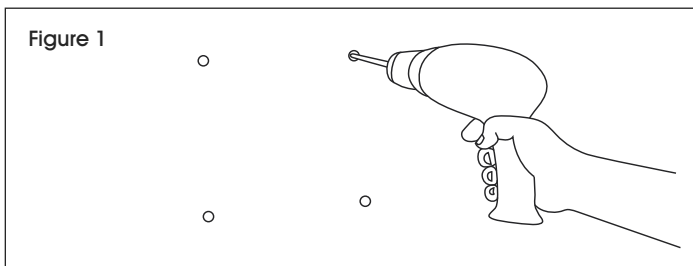

1. Ouvrez complètement le couvercle du distributeur à l'aide de la clé standard ou de la clé à enclenchement. Maintenez le distributeur contre le mur à l'emplacement de montage idéal.
2. Marquez les quatre trous sur le mur où les vis seront insérées.
3. Mettez le distributeur de côté et percez le mur aux quatre endroits marqués avec une mèche de perceuse appropriée. (Voir Figure 1)
4. Tenez le distributeur contre le mur de sorte que les trous dans le mur et ceux du distributeur correspondent. Insérez quatre vis dans les trous précédemment percés.



**REMARQUE :** Il est recommandé de placer le bas du distributeur à une hauteur de 54 po du sol. Laissez 12 po d'espace sous le distributeur pour permettre de tirer les serviettes et 4 po d'espace sur le côté droit pour accéder à la molette.

## CHARGEMENT

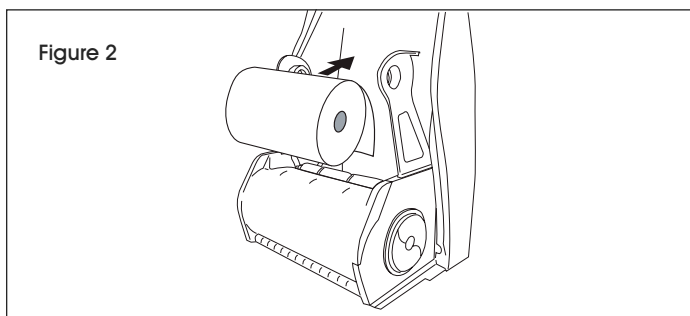

1. Installez le rouleau de serviettes de façon à ce qu'il se déroule depuis l'arrière. (Voir Figure 2)

## CHARGEMENT SUITE

Figure 3

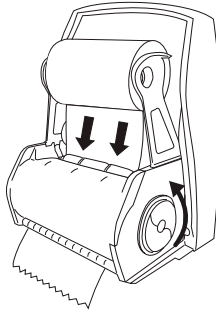

1. Insérez les serviettes en les faisant passer derrière et sous le rouleau blanc. Tournez la molette située sur le côté droit jusqu'à ce que les serviettes ressortent du module de distribution transparent. (Voir Figure 3)



**REMARQUE :** Il n'est pas nécessaire d'utiliser les pinces de transfert bleues pour charger un rouleau neuf.

## CHARGEMENT D'UN ROULEAU AUXILIAIRE

Figure 4

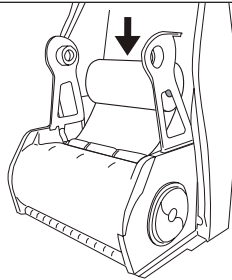

1. Retirez le rouleau auxiliaire des bras de soutien du rouleau sans dérouler les serviettes et placez-le dans le plateau de rouleau auxiliaire au bas du distributeur. (Voir Figure 4)
2. Installez un rouleau neuf sur les bras de soutien de rouleau en veillant à ce que le papier se déroule depuis l'arrière.

Figure 5

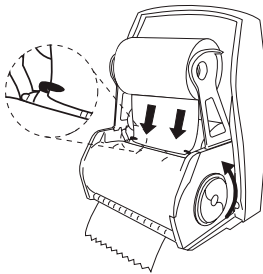

3. Insérez l'extrémité du nouveau rouleau de serviettes sous les pinces de transfert bleues. (Voir Figure 5)
4. Lorsque le rouleau auxiliaire est terminé, l'utilisateur peut commencer le rouleau chargé d'avance en tournant la molette sur deux tours complets.

## SERRURE ET CLÉ

- Une serrure standard avec clé standard amovible est fournie à des fins de sécurité.
- Si une serrure à clé n'est pas nécessaire, vous pouvez utiliser la clé à enclenchement fournie. La clé à enclenchement est installée en l'enfonçant fermement dans la serrure et en la faisant basculer légèrement jusqu'à ce qu'elle s'enclenche.

**ULINE**

1-800-295-5510  
uline.ca