

# ULINE H-1546 ROLLING CLOTHES RACK

1-800-295-5510  
uline.com

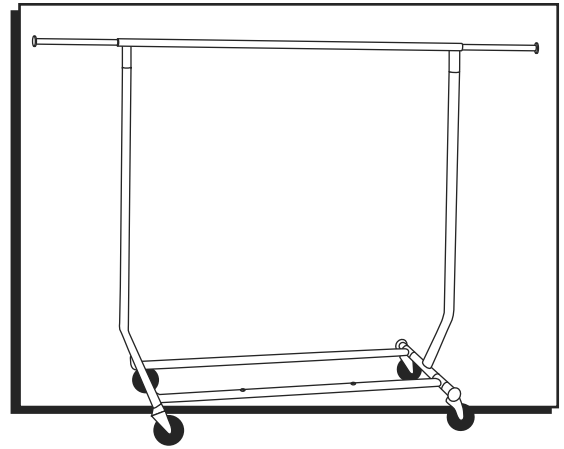

## PARTS LIST

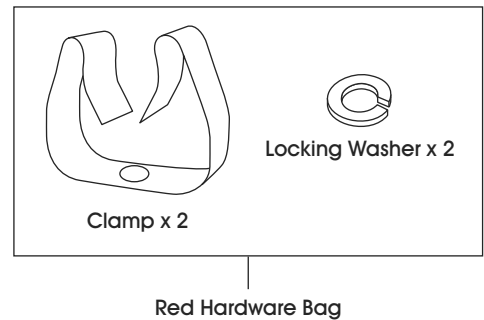
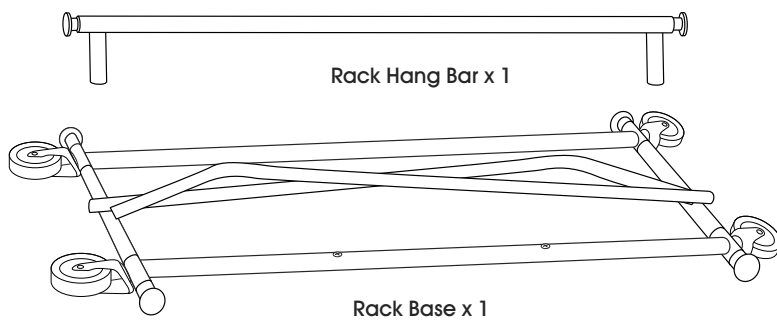

## INSTRUCTIONS

### TO ASSEMBLE RACK

1. Place rack base on ground and fold up arms.
2. Pull arms outward until uprights are stretched into complete vertical position; then, insert hang bar into arms. (See Figure 1)
3. To increase height pull up extensions if needed.

 **NOTE:** Hang bar can be lengthened by pulling out ends of hang bar.

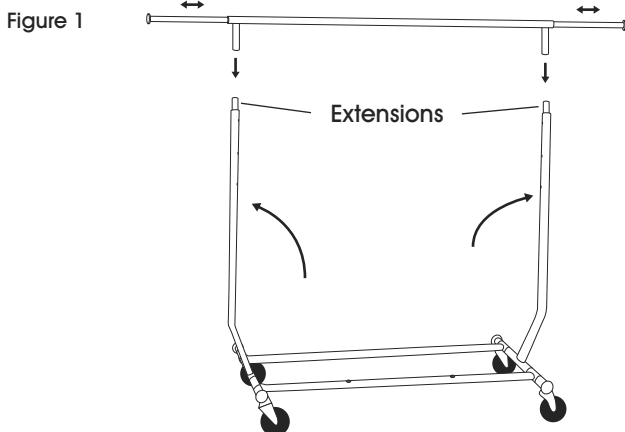

### FOR EASY TRANSPORTATION AND STORAGE

 **NOTE:** To attach clamps, first remove screws from base.

1. Remove hang bar, push in extensions if applicable, and fold down arms.
2. Attach clamps using locking washers and screws. (See Figure 2)
3. Snap hang bar into clamps.

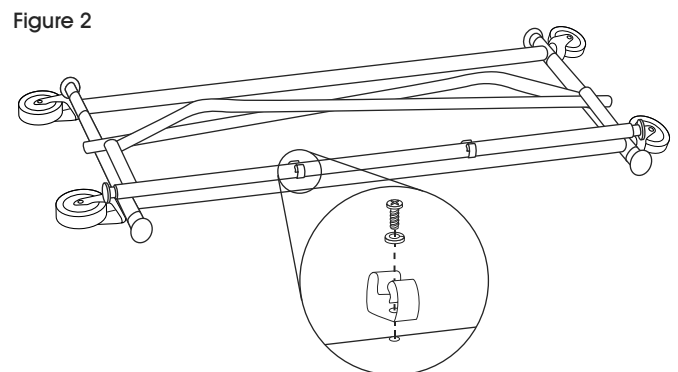

# ULINE H-1546

## RACK RODANTE PARA ROPA

800-295-5510  
uline.mx

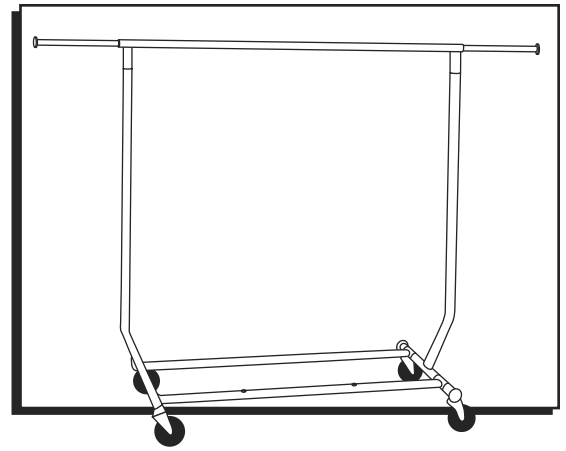

### LISTA DE PARTES

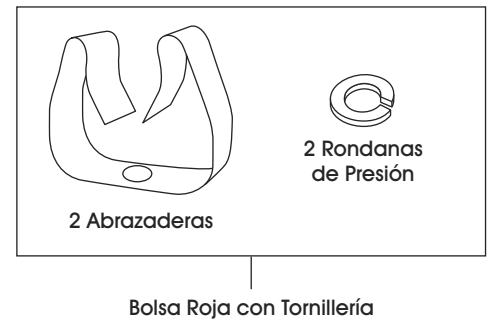
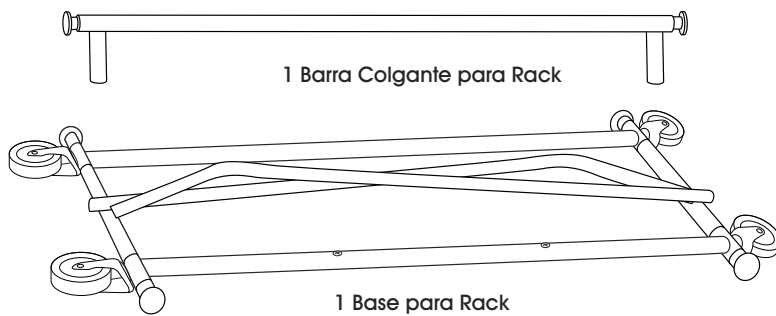

### INSTRUCCIONES

#### PARA ENSAMBLAR EL RACK

1. Coloque la base para rack sobre el piso y doble los brazos.
2. Jale los brazos hacia afuera hasta que se encuentren por completo en posición vertical; después, inserte la barra colgante en ellos. (Vea Diagrama 1)
3. Para incrementar la altura, jale de las extensiones si es necesario.

**NOTA:** La barra colgante puede alargarse jalando de los extremos hacia afuera.

Diagrama 1

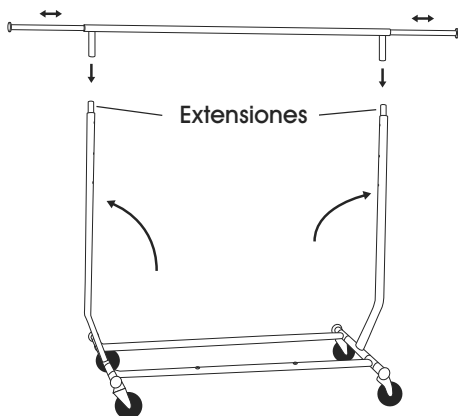

#### PARA FACILITAR EL TRANSPORTE Y ALMACENAMIENTO

**NOTA:** Para fijar las abrazaderas, quite primero los tornillos de la base.

1. Quite la barra colgante, empuje las extensiones hacia adentro en caso de ser aplicable y doble los brazos hacia abajo.
2. Fije las abrazaderas usando rondanas de presión y tornillos. (Vea Diagrama 2)
3. Inserte la barra colgante en las abrazaderas ejerciendo presión.

Diagrama 2

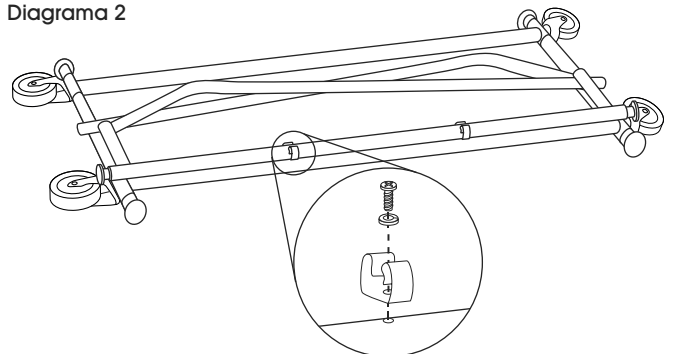

# ULINE H-1546

## SUPPORT À VÊTEMENTS MOBILE

1-800-295-5510  
uline.ca

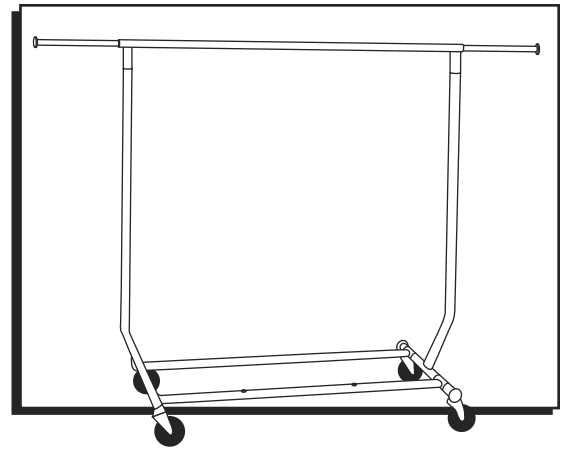

### LISTE DES PIÈCES

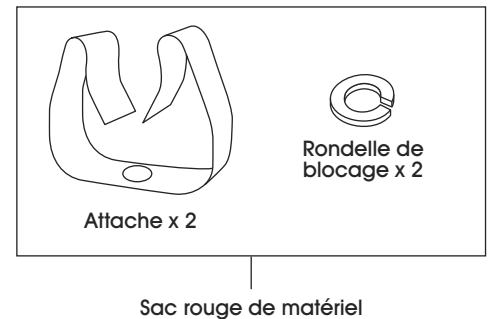
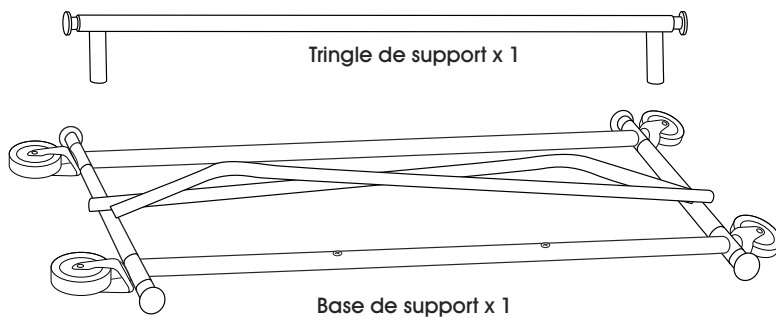

### INSTRUCTIONS

#### POUR ASSEMBLER LE SUPPORT

1. Déposez la base de support par terre et dépliez les bras.
2. Tirez les bras vers l'extérieur jusqu'à ce que les montants soient étirés entièrement en position verticale, puis insérez la tringle de support dans les bras. (Voir Figure 1)
3. Pour augmenter la hauteur, tirez sur les rallonges au besoin.

 **REMARQUE :** La tringle peut être allongée en tirant sur ses extrémités.

Figure 1

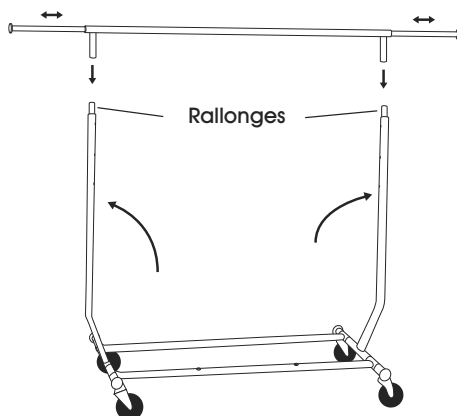

#### POUR FACILITER LE TRANSPORT ET L'ENTREPOSAGE

 **REMARQUE :** Pour fixer les attaches, retirez d'abord les vis de la base.

1. Retirez la tringle, rentrez les rallonges, le cas échéant, et rabattez les bras.
2. Fixez les attaches à l'aide de rondelles de blocage et de vis. (Voir Figure 2)
3. Encliquez la tringle dans les attaches.

Figure 2

