

**ULINE** H-1481, S-12548

1-800-295-5510  
uline.com

## HOG RING PLIER STAPLER

### COMPATIBLE STAPLES

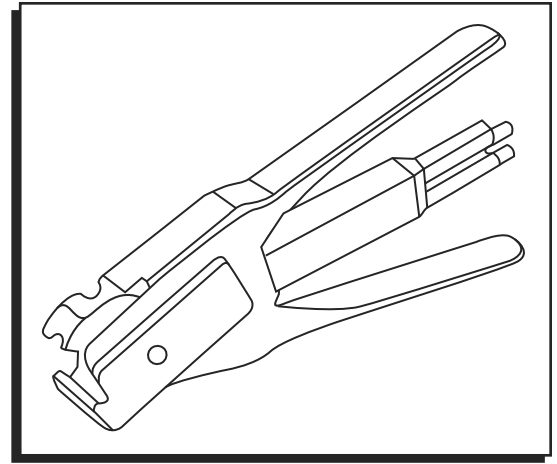

## DIAGRAM

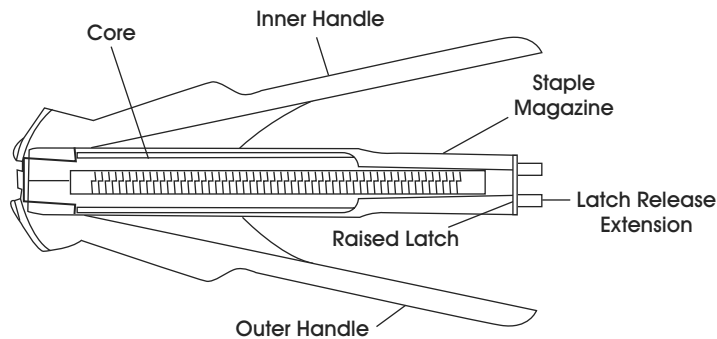

## LOADING

1. Grasp the plier handles in left hand, turning plier so staple magazine faces up.
2. Press the latch release extension at end of core with the thumb of right hand, placing forefinger of right hand on the raised latch, and pull core back to open staple magazine. (See Figure 1)
3. Insert staples into magazine.
4. Push core back toward nose of pliers to close staple magazine. (See Figure 2)

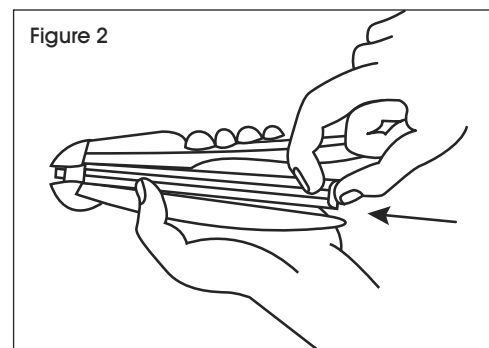
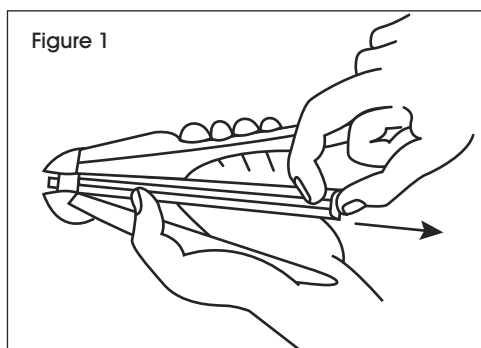

**ULINE** H-1481, S-12548

# ENGRAPADORA TIPO PINZA

800-295-5510  
uline.mx

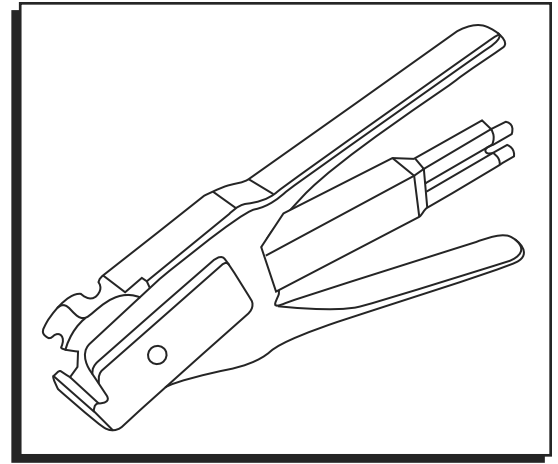

## GRAPAS COMPATIBLES



11/16"  
S-12548

## DIAGRAMA

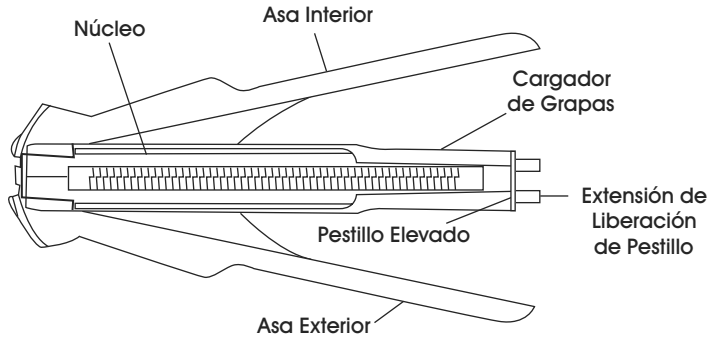

## CARGA

1. Sostenga las asas de la engrapadora con la mano izquierda, girando la engrapadora de forma que el cargador quede hacia arriba.
2. Presione, con el pulgar derecho, la extensión de liberación del pestillo ubicada en el extremo del núcleo, colocando el dedo índice derecho sobre el pestillo elevado. Luego jale el núcleo hacia atrás para abrir el cargador de grapas. (Vea Diagrama 1)
3. Inserte las grapas en el cargador.
4. Empuje el núcleo de regreso, hacia la punta de la engrapadora para cerrar el cargador. (Vea Diagrama 2)

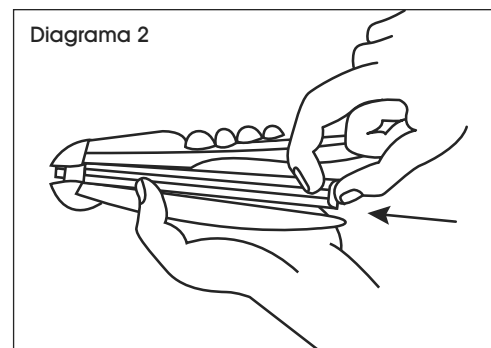
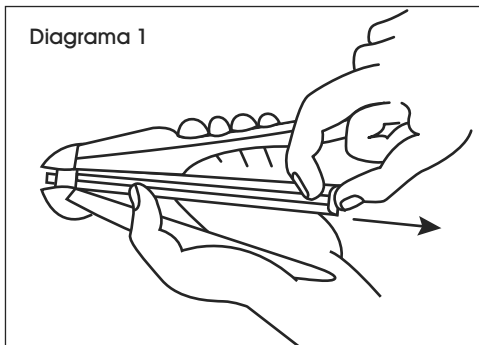

**ULINE** H-1481, S-12548

## PINCE À SERTIR DES AGRAFES

1-800-295-5510  
uline.ca

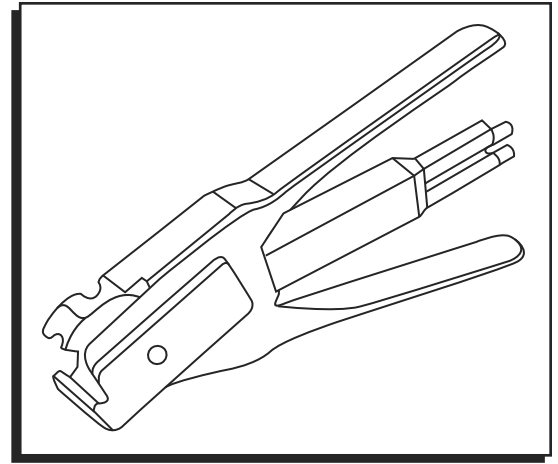

### AGRAFES COMPATIBLES



11/16 po  
S-12548

## SCHÉMA

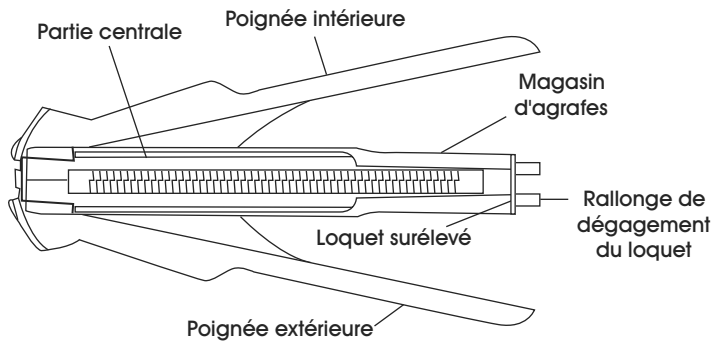

## CHARGEMENT

1. Saisissez les poignées de la pince avec votre main gauche, assurez-vous que la pince est tournée de façon à ce que le magasin d'agrafes soit orienté vers le haut.
2. Appuyez sur la rallonge de dégagement du loquet à l'extrémité de la partie centrale avec le pouce de la main droite, en plaçant l'index cette même main sur le loquet surélevé, et ramenez la partie centrale en position pour ouvrir le magasin d'agrafes. (Voir Figure 1)
3. Insérez les agrafes dans le magasin.
4. Repoussez la partie centrale vers l'avant de la pince pour fermer le magasin d'agrafes. (Voir Figure 2)

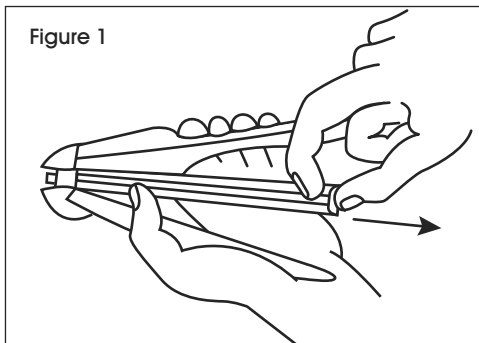

Figure 1

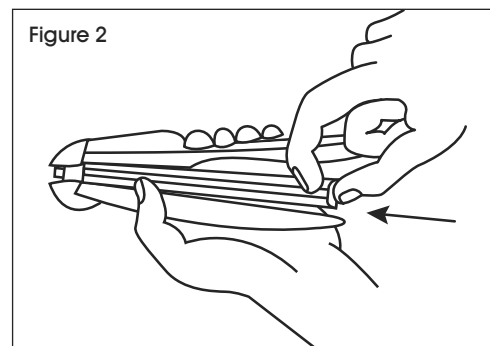

Figure 2