

ULINE H-1304

HEAVY DUTY ECONOMY PLASTIC PALLET

1-800-295-5510
 uline.com

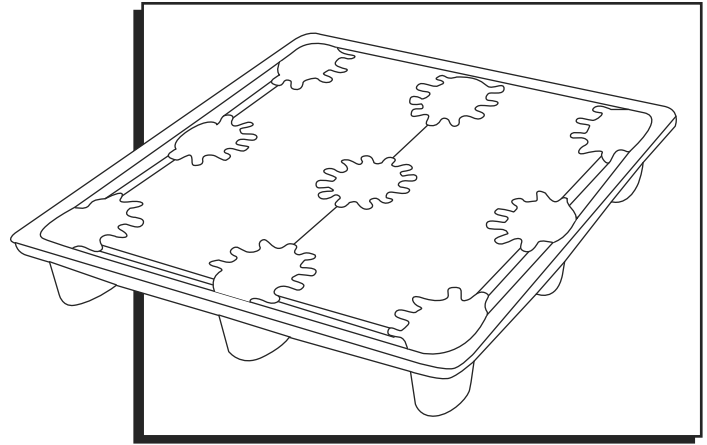

PRODUCT DIMENSIONS

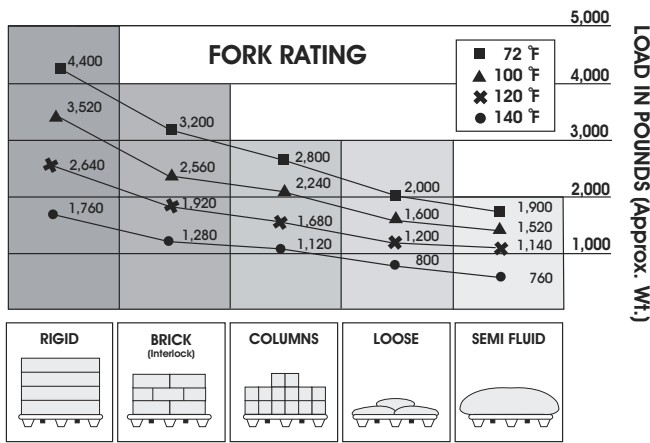

STACKING METHOD
 Fork rating differs with stacking method and facility's temperature.
 Please, note this change as it relates to your application.

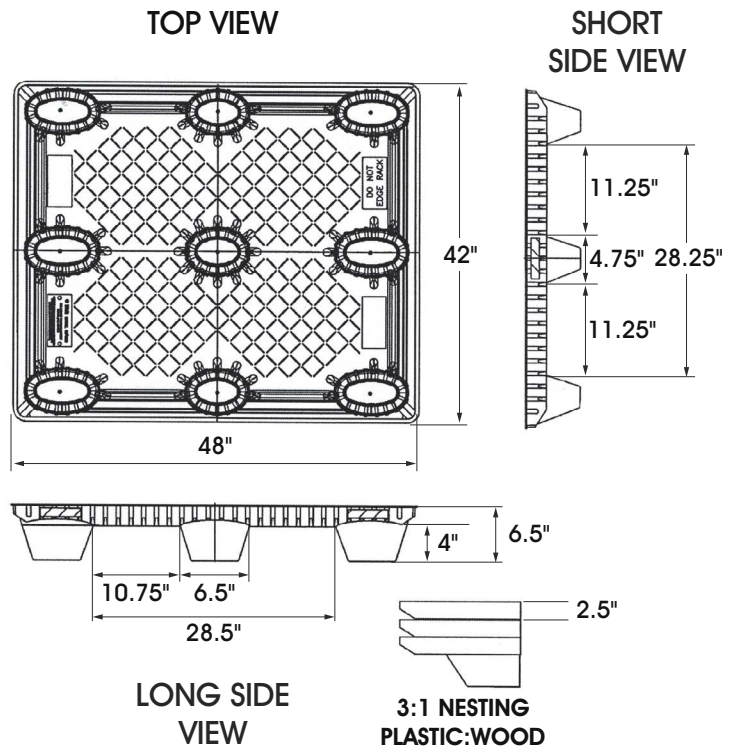

SPECIFICATIONS

MODEL #	DIMENSIONS		HEIGHT			NESTED TRAILER		WEIGHT CAPACITY		WEIGHT
	L	W	FORK	OVERALL	NESTING	48'	53'	FLOOR	FORK	
H-1304	48"	42"	4"	6.5"	2.50"	1,008	1,080	6,500 lbs.	2,500 lbs.	22 lbs.

ULINE H-1304

**TARIMA DE PLÁSTICO
ECONÓMICA PARA
USO PESADO**

800-295-5510
uline.mx

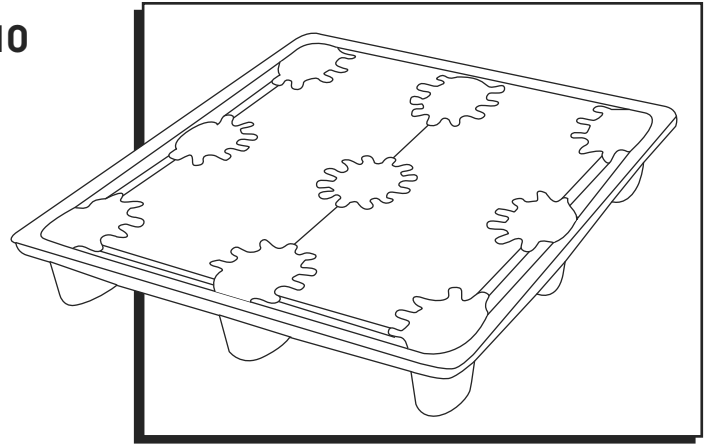

DIMENSIONES DEL PRODUCTO

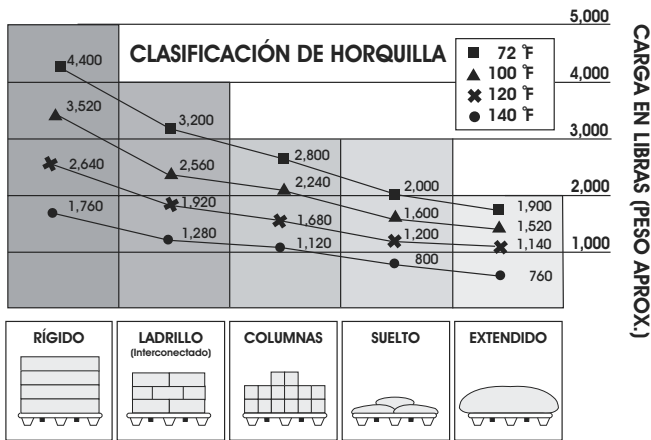

La clasificación de horquilla difiere con el método de estibación y la temperatura de las instalaciones. Favor de notar este cambio conforme se relacione con su aplicación.

CARGA EN LIBRAS (PESO APROX.)

VISTA SUPERIOR

VISTA DEL LADO CORTO

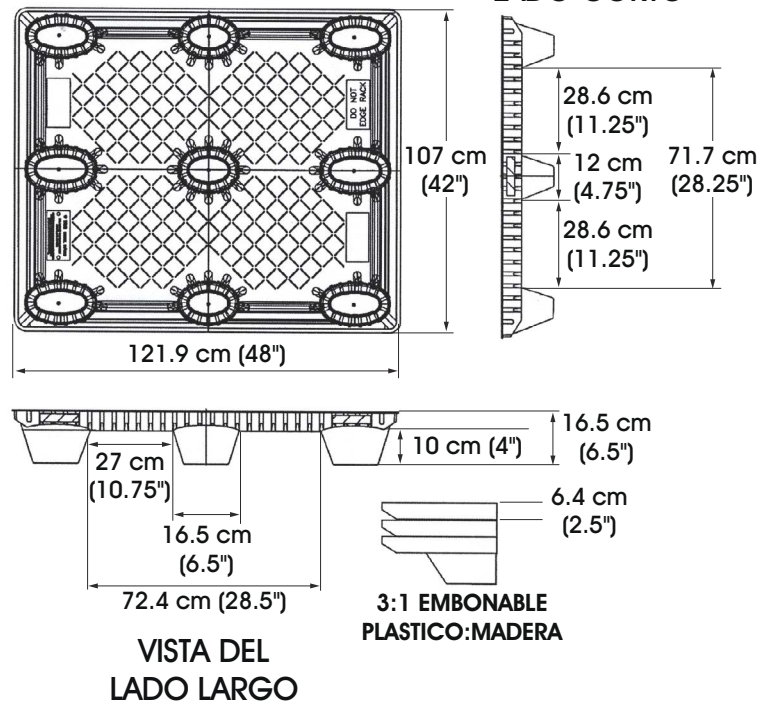

VISTA DEL LADO LARGO

ESPECIFICACIONES

MODELO NO.	DIMENSIONES		ALTURA			EMBONADAS EN TRÁILER		CAPACIDAD DE PESO		PESO
	LARGO	ANCHO	HORQUILLA	TOTAL	EMBONABLE	14.6 m (48')	16.15 m (53')	PISO	HORQUILLA	
H-1304	121.9 cm (48")	107 cm (42")	10 cm (4")	16.5 cm (6.5")	6.4 cm (2.5")	1,008	1,080	2,948 kg (6,500 lbs.)	1,133 kg (2,500 lbs.)	9.9 kg (22 lbs.)

ULINE H-1304

**PALETTE EN PLASTIQUE
ÉCONOMIQUE
ET ROBUSTE**

1-800-295-5510

uline.ca

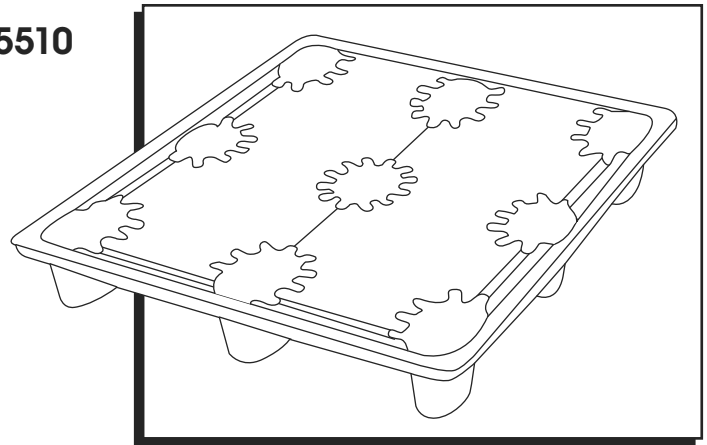

DIMENSIONS DU PRODUIT

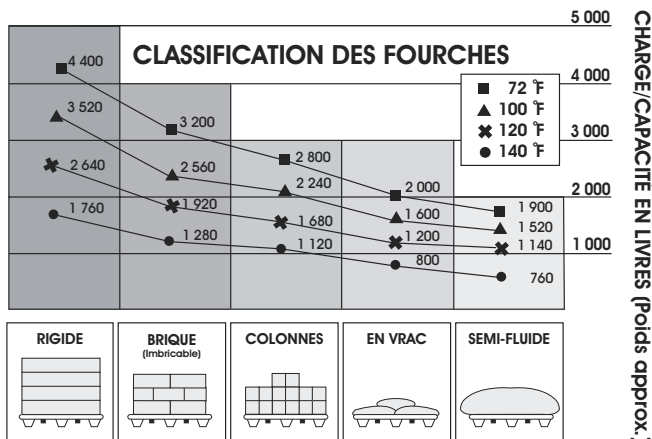

MÉTHODE D'EMPILAGE

La classification des fourches varie selon la méthode d'empilage et la température de l'établissement.

Veuillez prendre note de ce changement relatif à votre utilisation.

VUE DE DESSUS

VUE DU CÔTÉ COURT

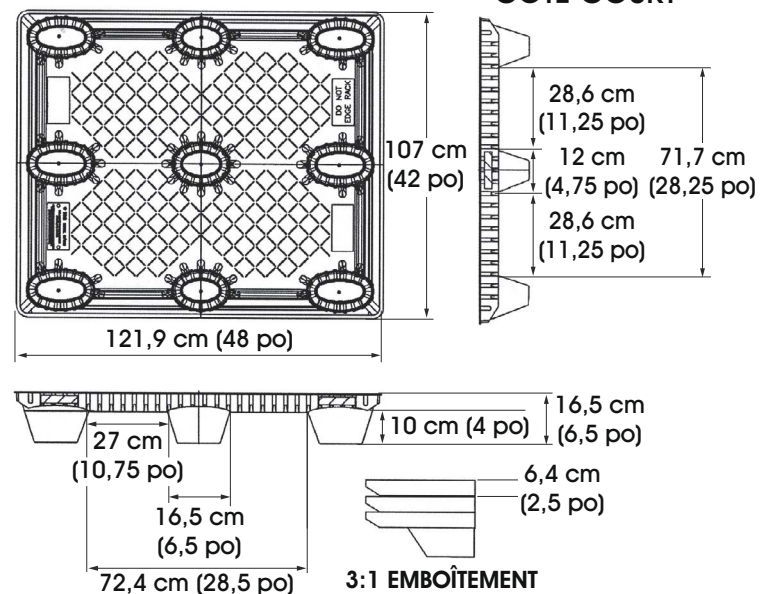

VUE DU CÔTÉ LONG

SPÉCIFICATIONS

N° DE MODÈLE	DIMENSIONS		HAUTEUR			REMORQUE EMBOÎTÉE		CAPACITÉ PONDÉRALE		POIDS
	LONG.	LARG.	FOURCHE	TOTALE	EMBOÏTEMENT	14,6 m (48 pi)	16,15 m (53 pi)	PLANCHER	FOURCHE	
H-1304	121,9 cm (48 po)	107 cm (42 po)	10 cm (4 po)	16,5 cm (6,5 po)	6,4 cm (2,5 po)	1 008	1 080	2 948 kg (6 500 lb)	1 133 kg (2 500 lb)	9,9 kg (22 lb)