

ULINE H-1273 STAINLESS STEEL TENSIONER

1-800-295-5510
uline.com

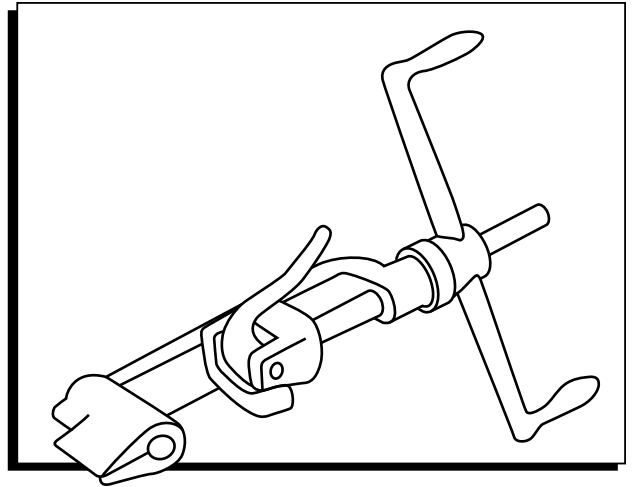

INSTRUCTIONS



CAUTION: Always wear safety goggles while using tensioner.

1. Slide buckle on band, bringing end of band around object to be clamped and again through buckle. (See Figure 1)

Figure 1



2. Wrap band around object once more and again through the buckle. Double banding develops a great deal more radial compression than single banding. Bend end of band under buckle. (See Figure 2)

Figure 2



3. Place band in the open slot of tool nose and slide in. With thumb on band gripper lever, turn wing handle of tool clockwise to apply tension. Release gripper lever (gripper lever locks itself under tension). (See Figure 3)

Figure 3

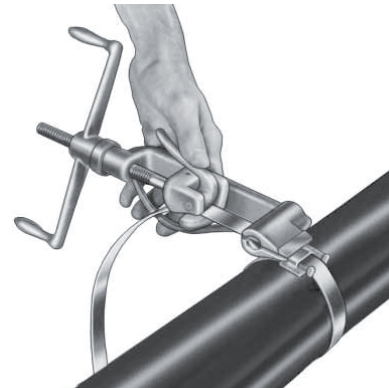

4. Place a finger on the band at the buckle bridge while turning (tensioning) wing handle. When you feel the band stop moving through the buckle, stop turning the handle. (See Figure 4)

Figure 4



INSTRUCTIONS CONTINUED

5. With the band still in the tool, roll tool over buckle and turn wing handle counter clockwise throughout the entire rolling operation. (See Figure 5)

 **NOTE:** Failure to loosen tension with wing handle throughout entire course of roll may cause band to break.

Figure 5



6. Pull cutting handle to cut the band. (See Figure 6).

Figure 6

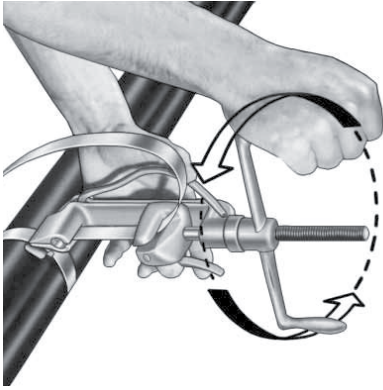
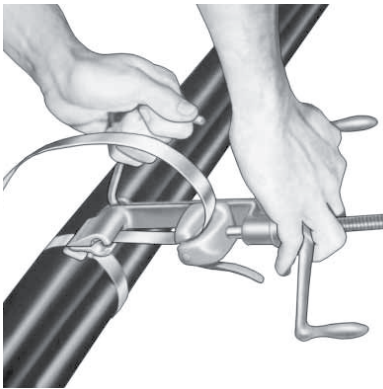

7. Hold down the stub of the band with your thumb and remove tool. (See Figure 7)

Figure 7

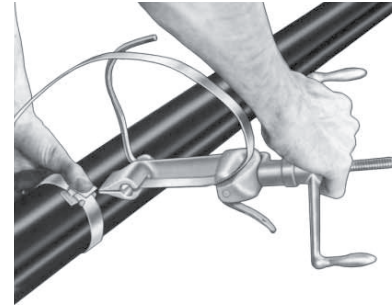

8. Clinch stub in place by hammering down buckle ears. Clamp is now complete. (See Figure 8)

Figure 8

