

ULINE

PACKING TABLE SHELF

1-800-295-5510
uline.com

TOOLS NEEDED

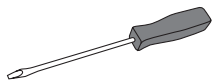

Slotted Screwdriver

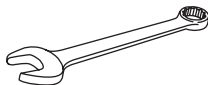

7/16" Wrench



Drill with 3/16" Drill Bit
(for non-steel tops only)

PARTS



Riser Support x 2



Riser Shelf x 1



Sway Brace x 2



#14 x 3/4" Wood Screw x 4



1/4"-20 x 5/8" Bolt x 16



1/4"-20 Nut x 16

ASSEMBLY INSTRUCTIONS

NOTE: Table should be in upright position.

1. Secure riser supports to table top using four 1/4-20 x 5/8" bolts and nuts for steel tops or four #14 x 3/4" wood screws for non-steel tops. (See Figure 1)

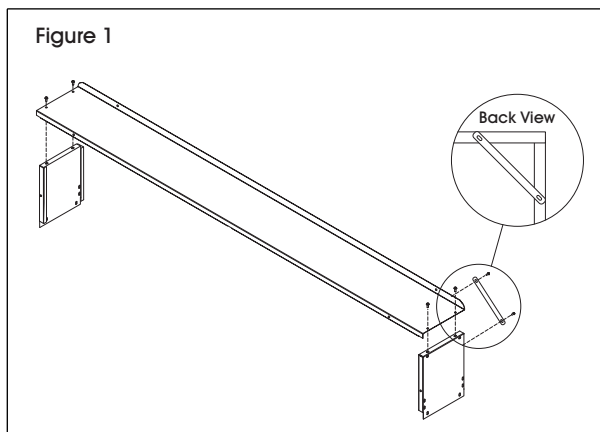

NOTE FOR NON-STEEL TOPS ONLY: Prior to attaching wood screws, drill two pilot holes into the bench through the holes at the bottom of the riser support using a 3/16" drill bit.

2. Secure riser shelf to supports using two 1/4-20 x 5/8" bolts and nuts on each end.
3. Secure sway braces to riser support and riser shelf using four 1/4-20 x 5/8" bolts and nuts.
4. Risers may be double stacked. Attach a second riser to the first using the same procedures for steel top above. (See Figures 2a and 2b)

NOTE: Do not stack more than one additional riser onto the original riser.

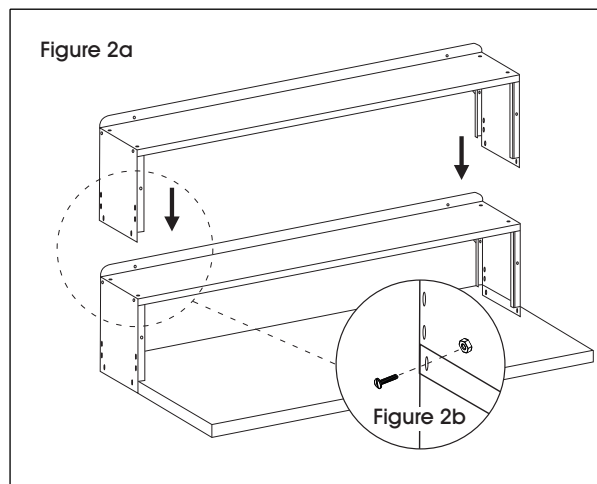

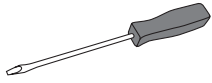
HERRAMIENTAS NECESARIAS

Desarmador Ranurado

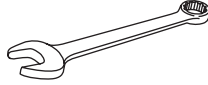

Llave de 7/16"

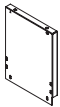
Taladro con Broca de Taladro de 3/16"
(solo para cubiertas que no sean de acero)**PARTES**

2 Soportes Elevadores

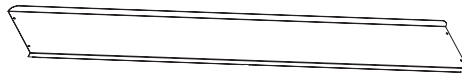

1 Repisa Elevada



2 Riostras



4 Tornillos para Madera #14 x 3/4"



16 Pernos 1/4-20 x 5/8"



16 Tuercas de 1/4"

INSTRUCCIONES DE ENSAMBLE**NOTA: La mesa debe estar en posición vertical**

1. Fije los soportes elevadores a la cubierta de la mesa usando cuatro pernos de 1/4-20 x 5/8" y tuercas para cubiertas de acero o cuatro tornillos para madera #14 x 3/4" para cubiertas que no sean de acero. (Vea Diagrama 1)

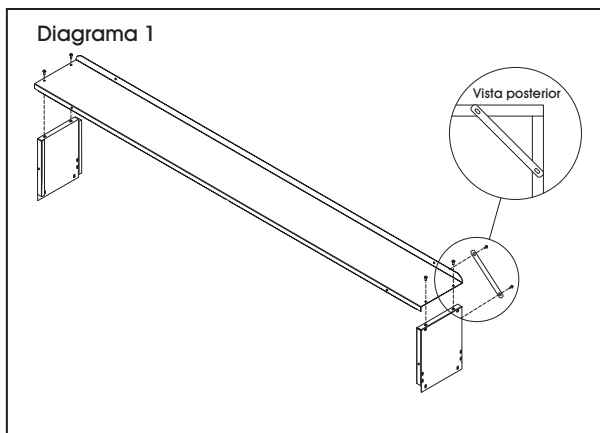

NOTA SOLO PARA CUBIERTAS QUE NO SEAN DE ACERO: Antes de colocar los tornillos para madera, taladre dos orificios piloto en cada banca a través de los orificios de la parte inferior del soporte elevador usando una broca de taladro de 3/16".

2. Fije la repisa elevada a los soportes usando dos pernos de 1/4-20 x 5/8" y tuercas en cada extremo.
3. Fije las riostras al soporte elevador y a la repisa elevada usando cuatro pernos de 1/4-20 x 5/8" y tuercas.
4. Los elevadores pueden estibarse. Coloque un segundo elevador sobre el primero siguiendo el mismo procedimiento indicado arriba para la cubierta de acero. (Vea Diagrama 2a y 2b)



NOTA: No estibe más de un elevador adicional sobre el elevador original.

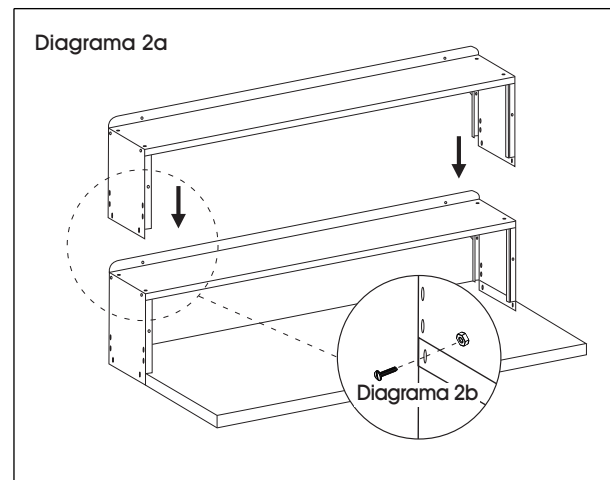

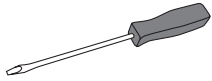
TABLETTE POUR TABLE D'EMBALLAGE**OUTILS REQUIS**

Tournevis pour écrous à fente

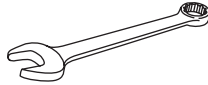

Clé de 7/16 po



Percez à l'aide d'une mèche de perceuse de 3/16 po (pour les dessus qui ne sont pas en acier seulement)

PIÈCES

Montant de support x 2



Tablette x 1

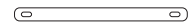

Renfort oblique x 2



Vis à bois n° 14 x 3/4 po x 4



Boulon de 1/4 po-20 x 5/8 po x 16



Écrou de 1/4 po-20 x 16

INSTRUCTIONS D'ASSEMBLAGE**REMARQUE : La table doit être debout**

- Fixez les montants de support au dessus de table à l'aide de quatre boulons et écrous de 1/4-20 x 5/8 po si le dessus est en acier ou de quatre vis à bois n° 14 x 3/4 po si le dessus n'est pas en acier. (Voir Figure 1)

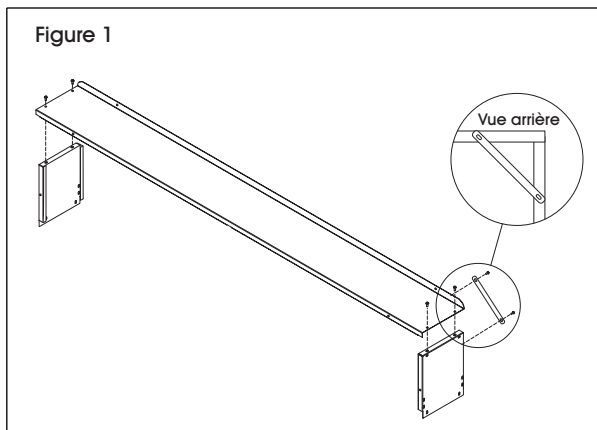

REMARQUE CONCERNANT LES DESSUS QUI NE SONT PAS EN ACIER : Avant de fixer les vis à bois, percez deux trous pilotes dans la tablette à travers les trous de la partie inférieure du montant de support à l'aide d'une mèche de perceuse de 3/16 po.

- Fixez la tablette aux supports à l'aide de deux boulons et écrous de 1/4-20 x 5/8 po à chaque extrémité.
- Fixez les renforts obliques aux montants de support à l'aide de quatre boulons et écrous de 1/4-20 x 5/8 po.
- Deux tablettes peuvent être placées l'une par-dessus l'autre. Suivez la même procédure décrite ci-dessus pour fixer une deuxième tablette sur la première. (Voir Figure 2a et 2b)



REMARQUE : N'empilez pas plus d'un montant supplémentaire sur le premier montant.

