

ULINE H-10093

DOWNTOWN COLLECTION – MOBILE STORAGE PEDESTAL FILE

1-800-295-5510
uline.com

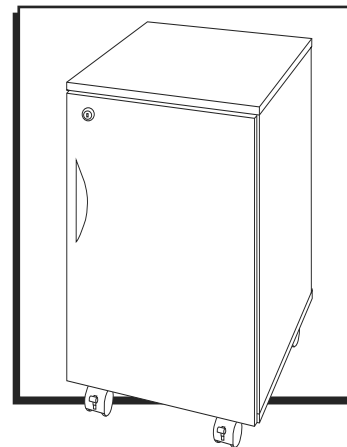

TOOL NEEDED

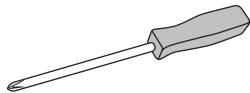

Phillips Screwdriver



Two Person Assembly
Recommended

PARTS

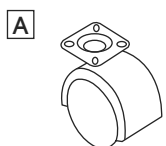

Caster x 2

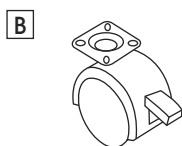

Locking Caster x 2



M4 x 16 mm
Screw x 16

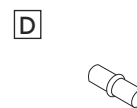

Shelf Pin x 4

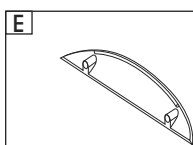

Handle x 1



Screw x 2
M4 x 22 mm

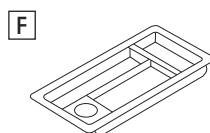

Supply Tray x 1

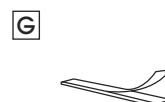

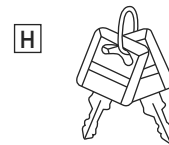

EVA Strip x 2

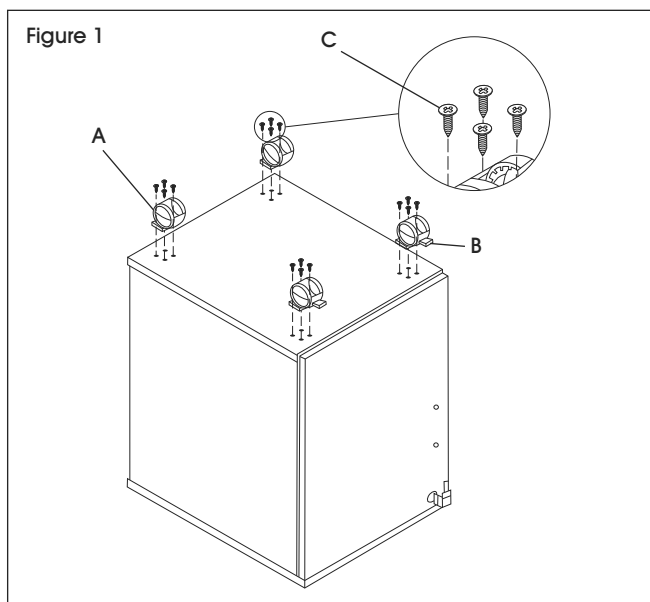

Keys (Set of 2) x 1

ASSEMBLY



 **NOTE:** Assemble unit on a smooth, non-marring surface to prevent scratching.

 **NOTE:** Check that all parts are included. Hardware is included in top drawer.

1. Place cabinet upside down. Align holes on the locking caster with the pre-drilled holes near the front of the unit. Attach using four M4 x 16 mm screws. Repeat for second locking caster. (See Figure 1)
2. Align holes on casters with the pre-drilled holes towards the back of the unit. Attach using four M4 x 16 mm screws. Repeat for second caster. (See Figure 1)

ASSEMBLY CONTINUED

Figure 2

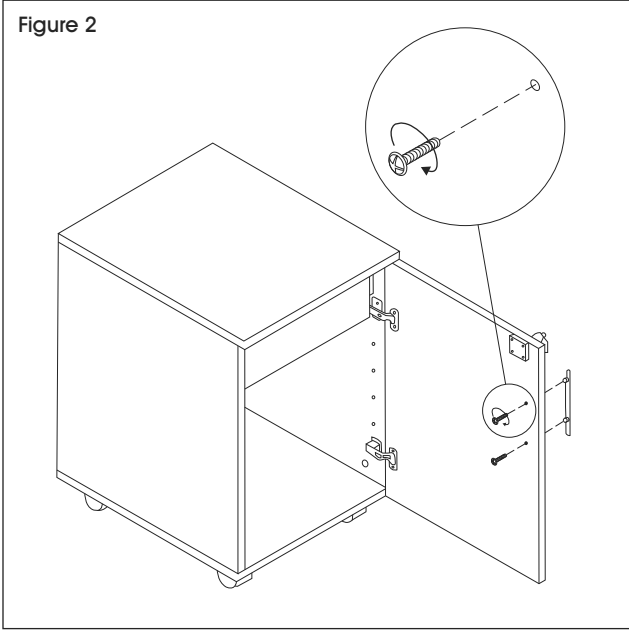

3. Place pedestal upright. Remove pre-attached handle from the inside of the door and attach to the outside of the door using two screws. (See Figure 2)

Figure 3

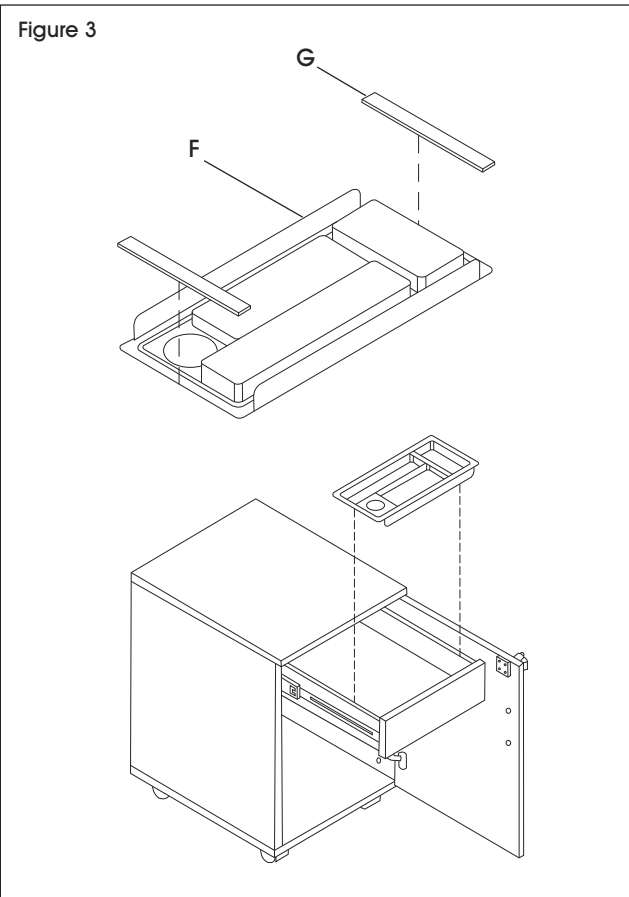

4. Attach two self-adhesive EVA strips to the underside of both ends of the supply tray and place in the top drawer. (See Figure 3)



NOTE: Only one side of the EVA strips has adhesive to stick to the supply tray. The other side will rest on the drawer side to prevent the supply tray from moving.

ASSEMBLY CONTINUED

Figure 4

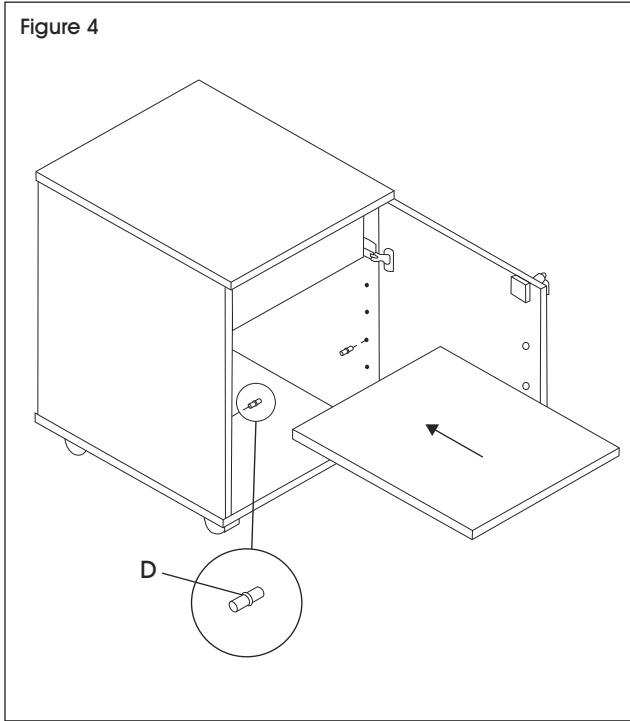

5. Install shelf pins into desired locations in each side panel. Place shelf on top of pins. (See Figure 4)

ULINE

1-800-295-5510
uline.com

ULINE H-10093

COLECCIÓN URBANA – ARCHIVERO MÓVIL DE PEDESTAL

800-295-5510

uline.mx

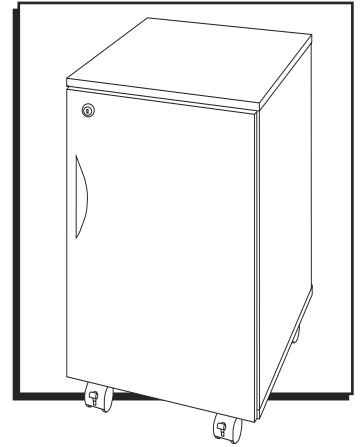

HERRAMIENTA NECESARIA

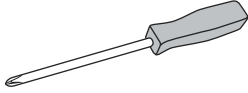

Desarmador de Cruz



Se recomienda Armar
Entre Dos Personas

PARTES

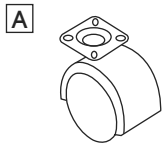

2 Ruedas

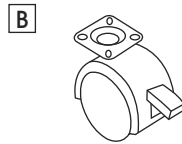

2 Ruedas con Seguro

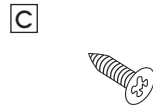

16 Tornillos
M4 x 16 mm

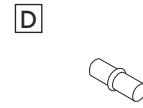

4 Pasadores para
Repisa

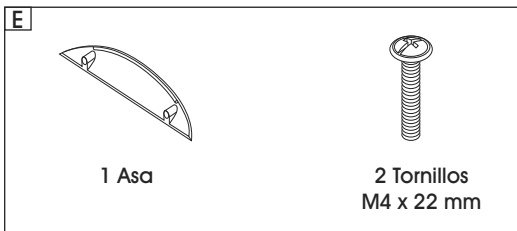

1 Asa

2 Tornillos
M4 x 22 mm

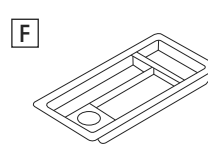

1 Bandeja para
Escritorio

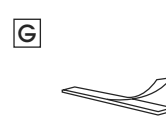

2 Tiras Adhesivas de
Espuma



1 Set de 2 Llaves

ENSAMBLE

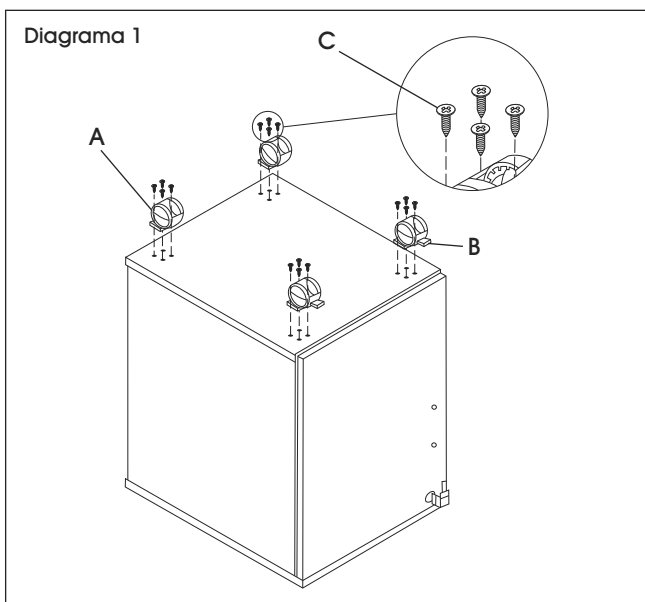

NOTA: Ensamble la unidad sobre una superficie lisa que no deje marcas para evitar rayones.



NOTA: Verifique que todas las partes estén incluidas. La tornillería se encuentra en el cajón superior.

1. Voltee el archivero de cabeza. Alinee los orificios de la rueda con seguro con los orificios preperforados cerca de la parte frontal de la unidad. Fije utilizando cuatro tornillos M4 x 16 mm. Repita la operación con la segunda rueda con seguro. (Vea Diagrama 1)
2. Alinee los orificios de las ruedas sin seguro con los orificios preperforados cerca de la parte posterior de la unidad. Fije utilizando cuatro tornillos M4 x 16 mm. Repita la operación con la segunda rueda sin seguro. (Vea Diagrama 1)

CONTINUACIÓN DE ENSAMBLE

Diagrama 2

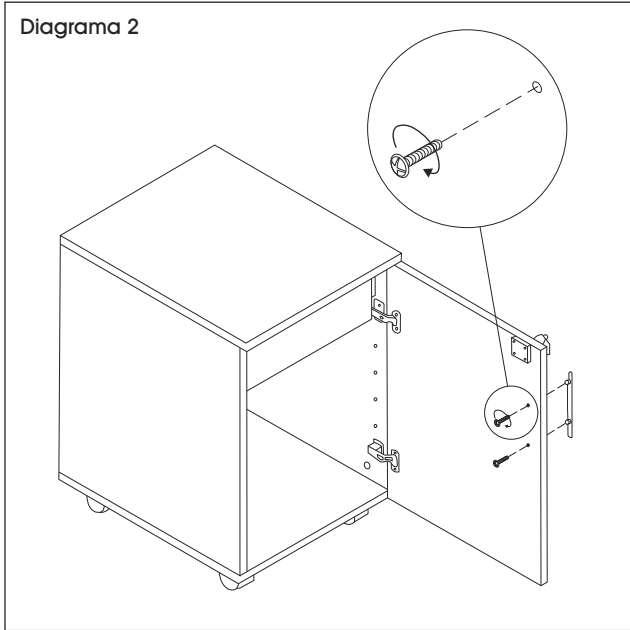

3. Coloque el pedestal en posición vertical. Retire el asa que viene preinstalada dentro de la puerta e instálela por fuera utilizando dos tornillos. (Vea Diagrama 2)

Diagrama 3

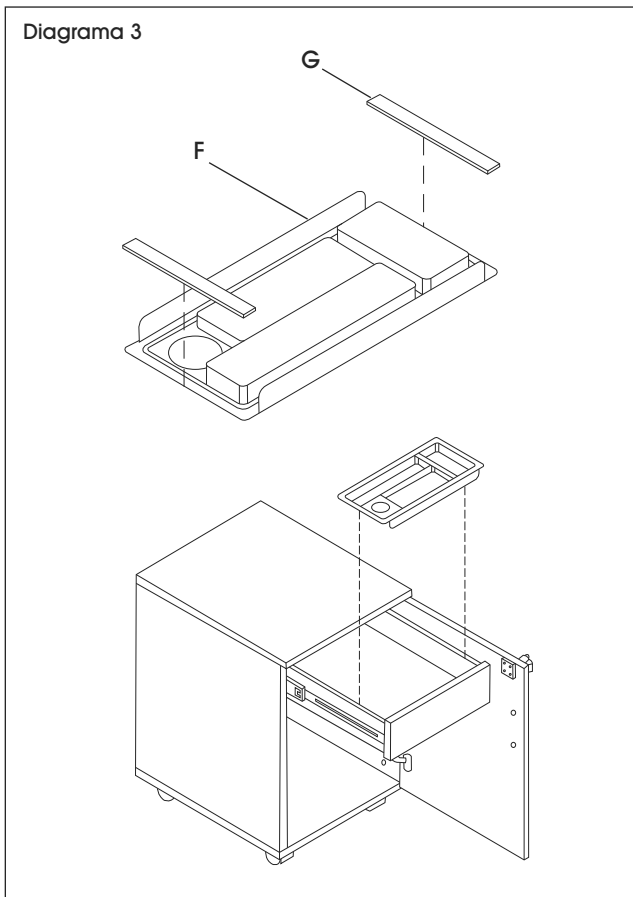

4. Adhiera las dos tiras adhesivas de espuma a la parte posterior de los bordes de la bandeja para escritorio y colóquela en el cajón superior. (Vea Diagrama 3)

 **NOTA:** Solo un lado de las tiras de espuma tiene adhesivo para pegarlas a la bandeja para escritorio. El otro lado se apoyará en la orilla del cajón para evitar que la bandeja se mueva.

CONTINUACIÓN DE ENSAMBLE

Diagrama 4

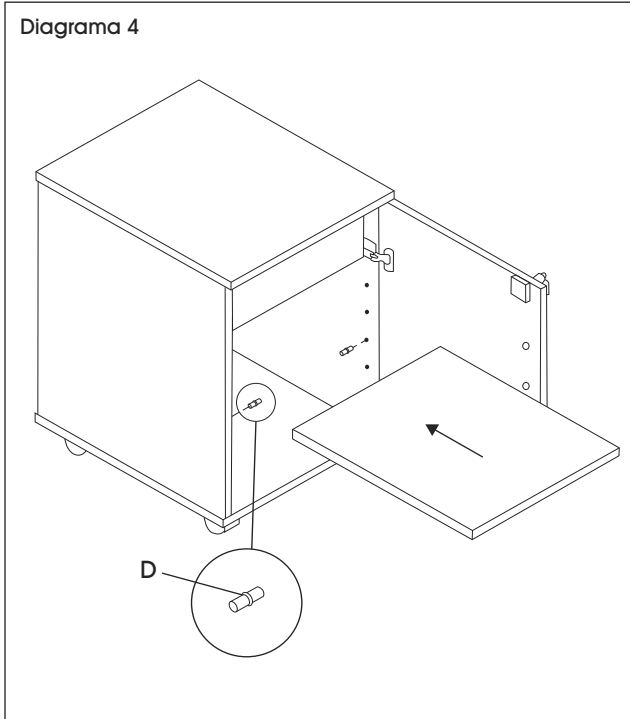

5. Instale los pasadores para repisa en el lugar deseado en cada panel lateral. Coloque la repisa sobre los pasadores. (Vea Diagrama 4)

ULINE H-10093

COLLECTION DOWNTOWN – CLASSEUR MOBILE À CAISSON

1-800-295-5510

uline.ca

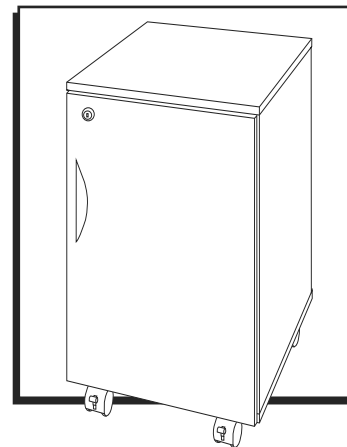

OUTIL REQUIS

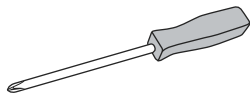

Tournevis cruciforme



Montage à deux
personnes recommandé

PIÈCES

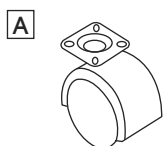

Roulette x 2

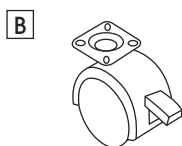

Roulette blocable x 2



Vis M4 x 16 mm x 16

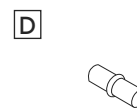

Taquet x 4

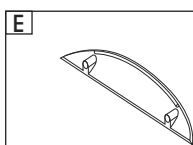

Poignée x 1



Vis x 2
M4 x 22 mm

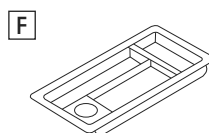

Plateau pour
fournitures x 1

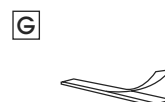

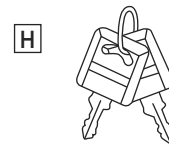

Bande en CAV/E x 2

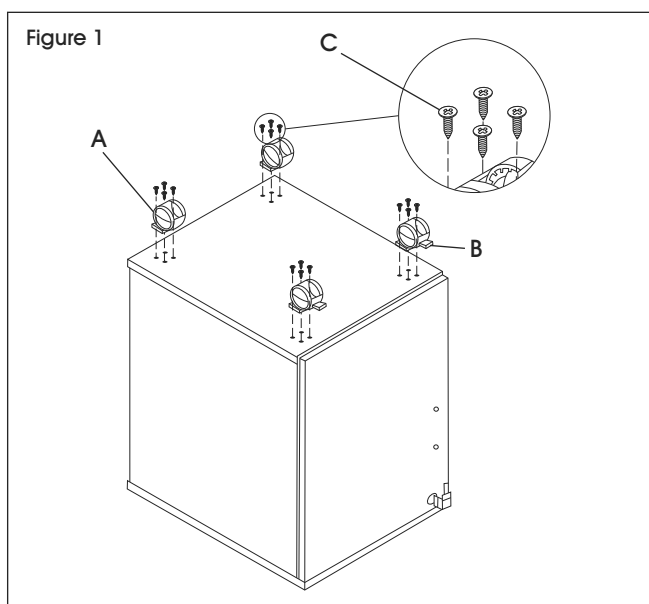

Clés (jeu de 2) x 1

MONTAGE



 **REMARQUE :** Montez le meuble sur une surface lisse qui ne marque pas afin d'éviter les rayures.

 **REMARQUE :** Vérifiez que toutes les pièces sont incluses. Le matériel d'installation se trouve dans le tiroir supérieur.

1. Placez le classeur à l'envers. Alignez les trous de l'une des roulettes blocables sur les trous prépercés près de la face avant du classeur. Fixez avec quatre vis M4 x 16 mm. Répétez l'opération pour la deuxième roulette blocable. (Voir Figure 1)
2. Alignez les trous des roulettes sur les trous prépercés près de la face arrière du classeur. Fixez avec quatre vis M4 x 16 mm. Répétez l'opération pour la deuxième roulette. (Voir Figure 1)

MONTAGE SUITE

Figure 2

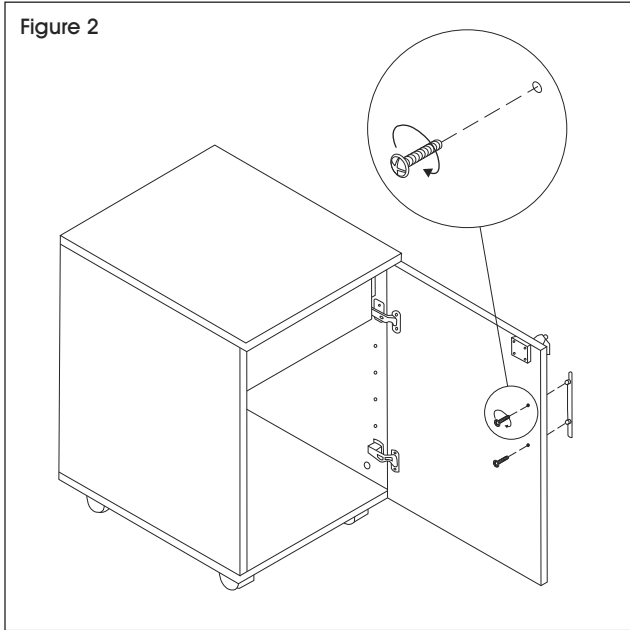

3. Placez le caisson à l'endroit. Retirez et sortez la poignée préfixée se trouvant derrière la porte et positionnez-la à l'extérieur de la porte au moyen de deux vis. (Voir Figure 2)

Figure 3

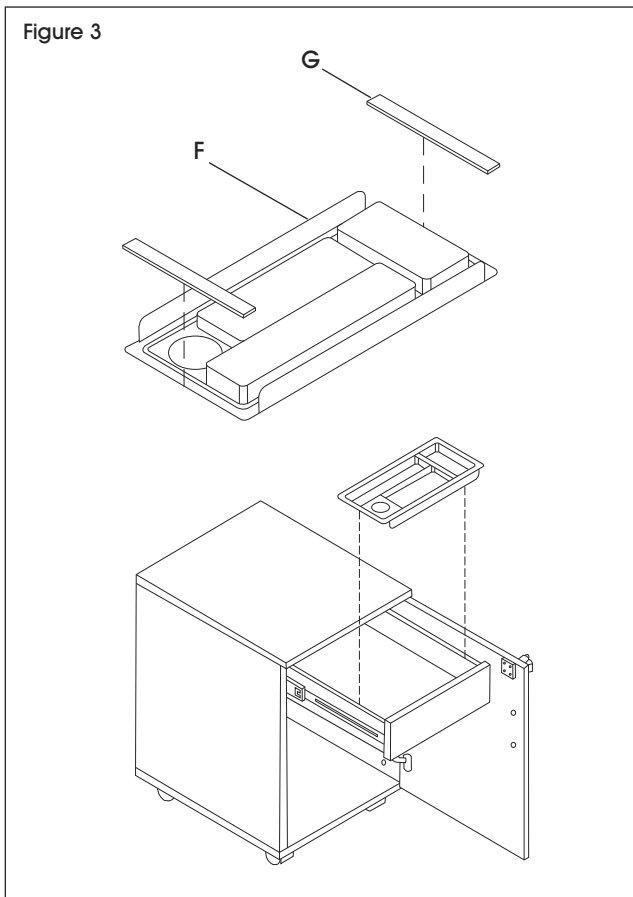

4. Fixez les deux bandes autoadhésives en CAV/E sur le dessous de chacune des extrémités du plateau pour fournitures, puis insérez le plateau dans le tiroir supérieur. (Voir Figure 3)

 **REMARQUE :** Seule l'une des faces des bandes en CAV/E est adhésive, ce qui permet une fixation sur le plateau pour fournitures. L'autre côté doit reposer sur le rebord du tiroir ce qui permet d'éviter le déplacement du plateau pour fournitures.

MONTAGE SUITE

Figure 4

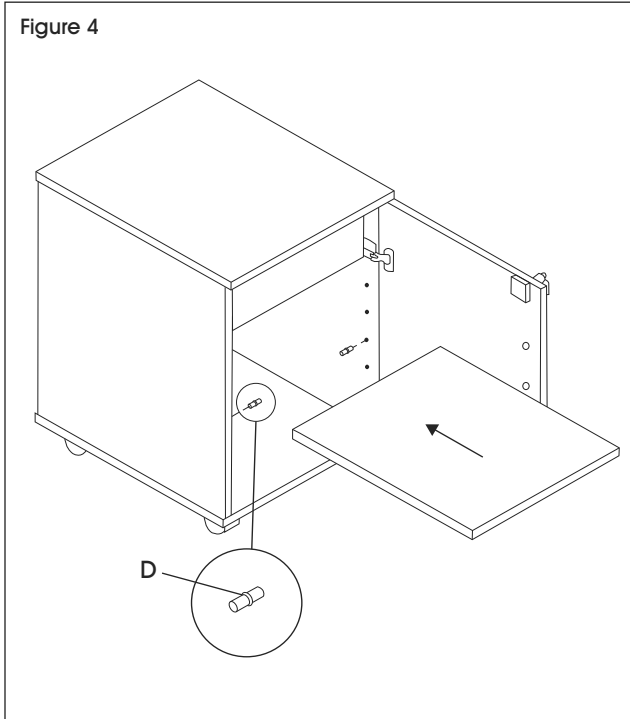

5. Installez les taquets à la hauteur voulue dans chacun des panneaux latéraux. Déposez la tablette sur les taquets. (Voir Figure 4)

ULINE

1-800-295-5510
uline.ca