

ULINE H-1246
H-1247
**IMPULSE POLY BAG
SEALER**

1-800-295-5510
uline.com

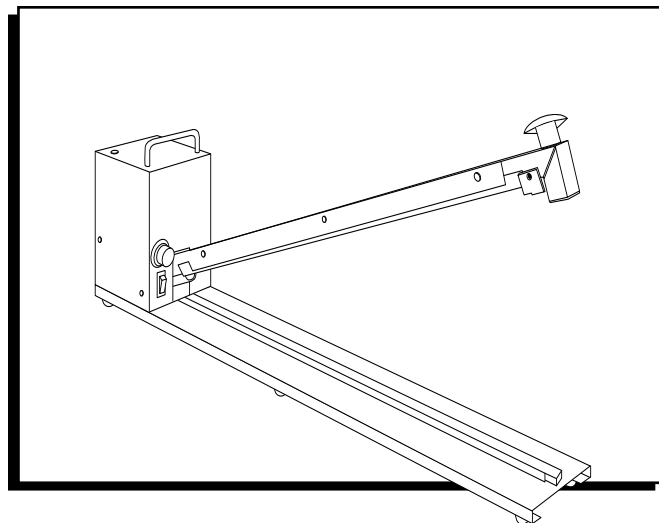

TROUBLESHOOTING

OPERATING ISSUE	RECOMMENDATIONS
Bag is melting.	Start with timer on the lowest setting possible. This will also preserve the heating element.
Sealer is not producing a good seal all the way across.	<ol style="list-style-type: none">1. Place additional pressure on the sealing arm.2. Hold the sealing arm down for 2-4 seconds after the sealing light goes out.3. Heating element may need to be replaced.
Sealer is not sealing.	Heating element may need to be replaced.
Heating element is burning out too quickly.	Set timer knob to lowest setting that produces a good seal for the bag thickness. Thicker bags need a higher setting. (Always start with a low setting and increase gradually.)