

**ULINE** H-1649, H-1650, H-1651  
H-1653, H-1654  
**EASY-COUNT SCALES**

1-800-295-5510  
uline.com

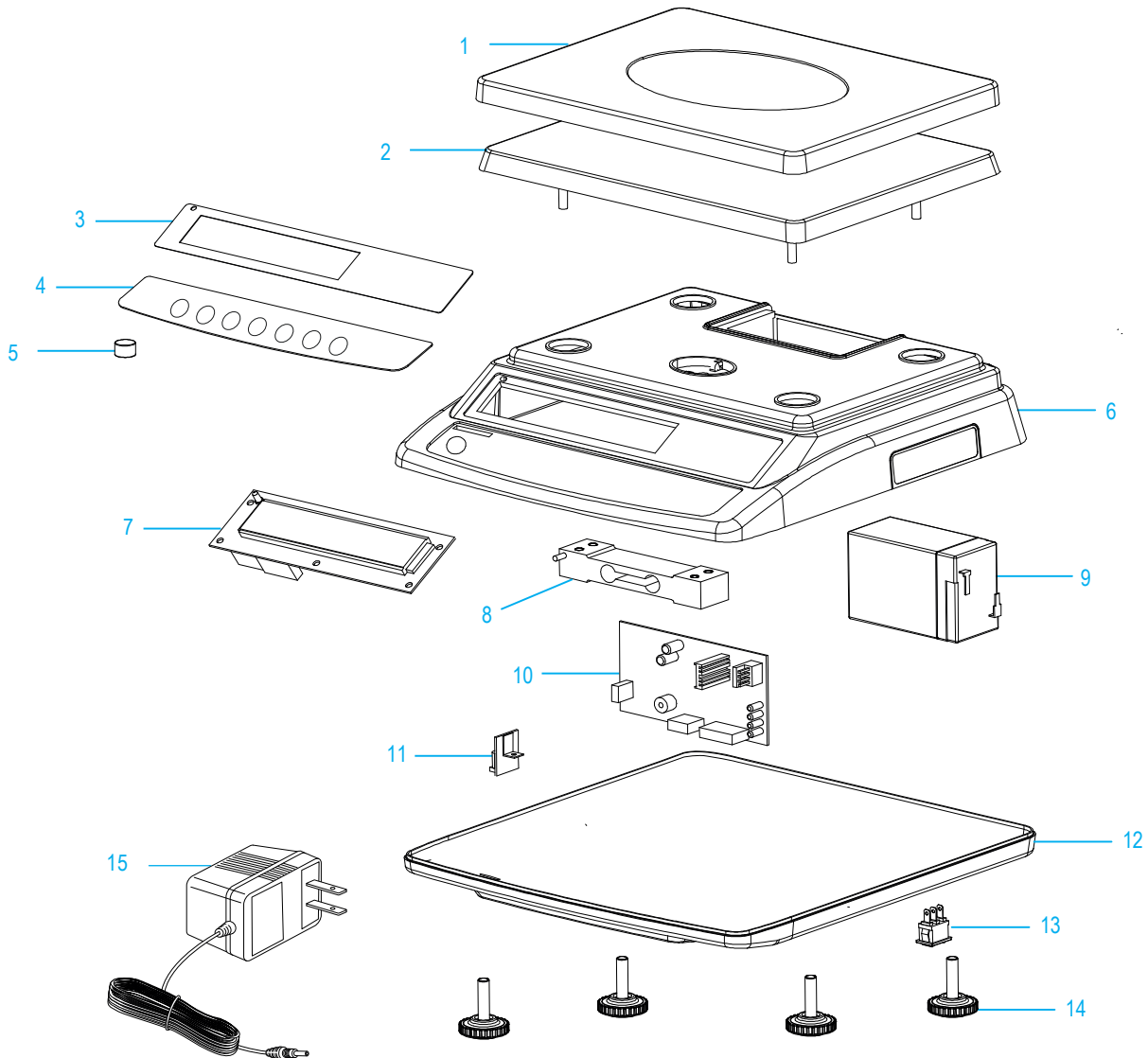
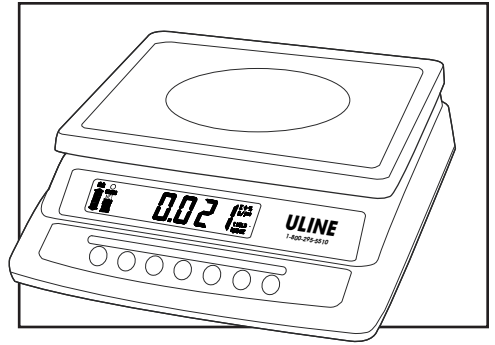

#	DESCRIPTION	QTY.	ULINE PART NO.	MFG. PART NO.
1	Stainless Steel Weighing Pan	1	-----	113400231
2	Plastic Weighing Pan	1	H-1650-PAN	111700127
3	Display Overlay for H-1649	1	-----	113701185
3	Display Overlay for H-1650	1	-----	113701186
3	Display Overlay for H-1651	1	H-1651-OVRLY	113701184
3	Display Overlay for H-1653	1	-----	113701188
3	Display Overlay for H-1654	1	-----	113701187
4	Keypad Overlay for H-1649	1	H-1649-351	113500760
4	Keypad Overlay for H-1650	1	H-1650-352	113500761
4	Keypad Overlay for H-1651	1	H-1651-353	113500762
4	Keypad Overlay for H-1653	1	H-1653-354	113500763
4	Keypad Overlay for H-1654	1	H-1654-355	113500764
5	Level Indicator	1	-----	112200009
6	Upper Housing	1	H-1651-TPCVR	111700163
7	Display Board	1	H-1650-DISP	120100366
8	Load Cell for H-1649	1	H-1649-CELL	113000620
8	Load Cell for H-1650	1	H-1650-CELL	113000621
8	Load Cell for H-1651	1	H-1651-CELL	113000622
8	Load Cell for H-1653 and H-1654	1	H-1653-CELL	113000617
9	Battery	1	H-1652	110200029
10	Mainboard	1	H-1654-MB14B	120100372
11	AC Adapter Power Socket	1	H-1651-PWRSK	120100415
12	Lower Housing	1	-----	111700333
13	On/Off Power Switch	1	H-1653-9	120300102
14	Foot	4	H-1651-FEET	111700134 111800102
15	12V AC Adapter	1	H-1654-ADAPT	111200032
15	9V AC Adapter	1	H-1564-9VLT	111200018
	Dust Cover (Not Shown)	1	H-1651-DCVR	112700347