

ULINE H-1542
**DUAL HANDLE
 STEEL HAND TRUCK**

1-800-295-5510
 uline.com

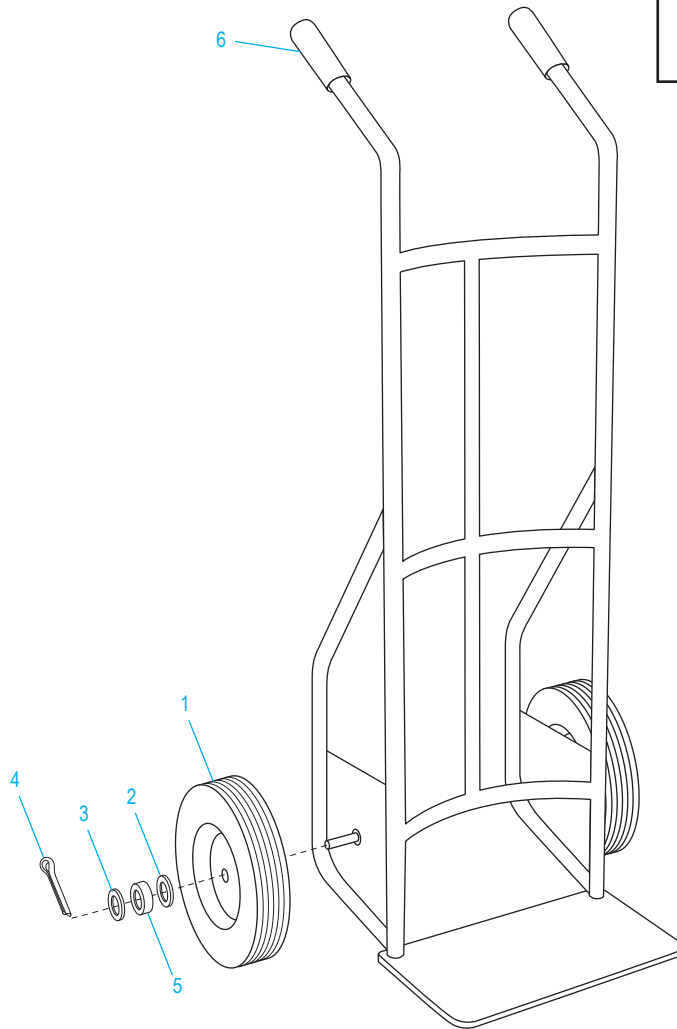
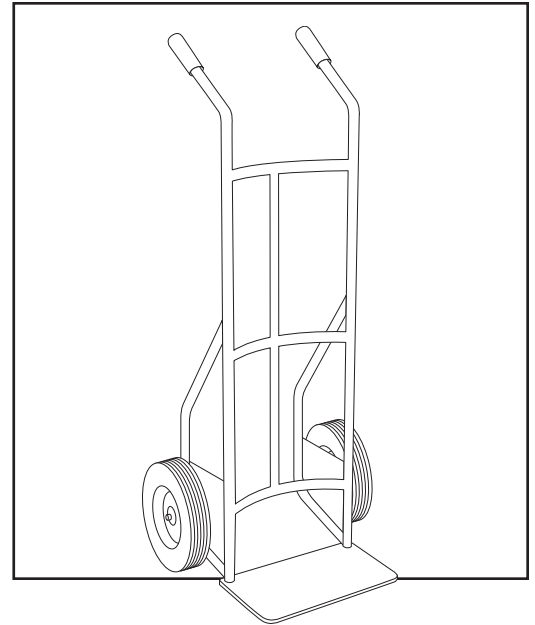

#	DESCRIPTION	QTY.	ULINE PART NO.	MFG. PART NO.
1	10" Solid Wheel	2	H-3358	W-005
2	Washer (2mm)	2	-----	-----
3	Washer (1mm)	2	-----	-----
4	Cotter Pin	2	-----	-----
5	Spacer (20mm)	2	-----	-----
6	White Handle Grip	2	H-1549GRIP	MIGGS934