

ULINE H-1276, H-1981
**AUTOMATIC
LABEL DISPENSER**

1-800-295-5510
uline.com

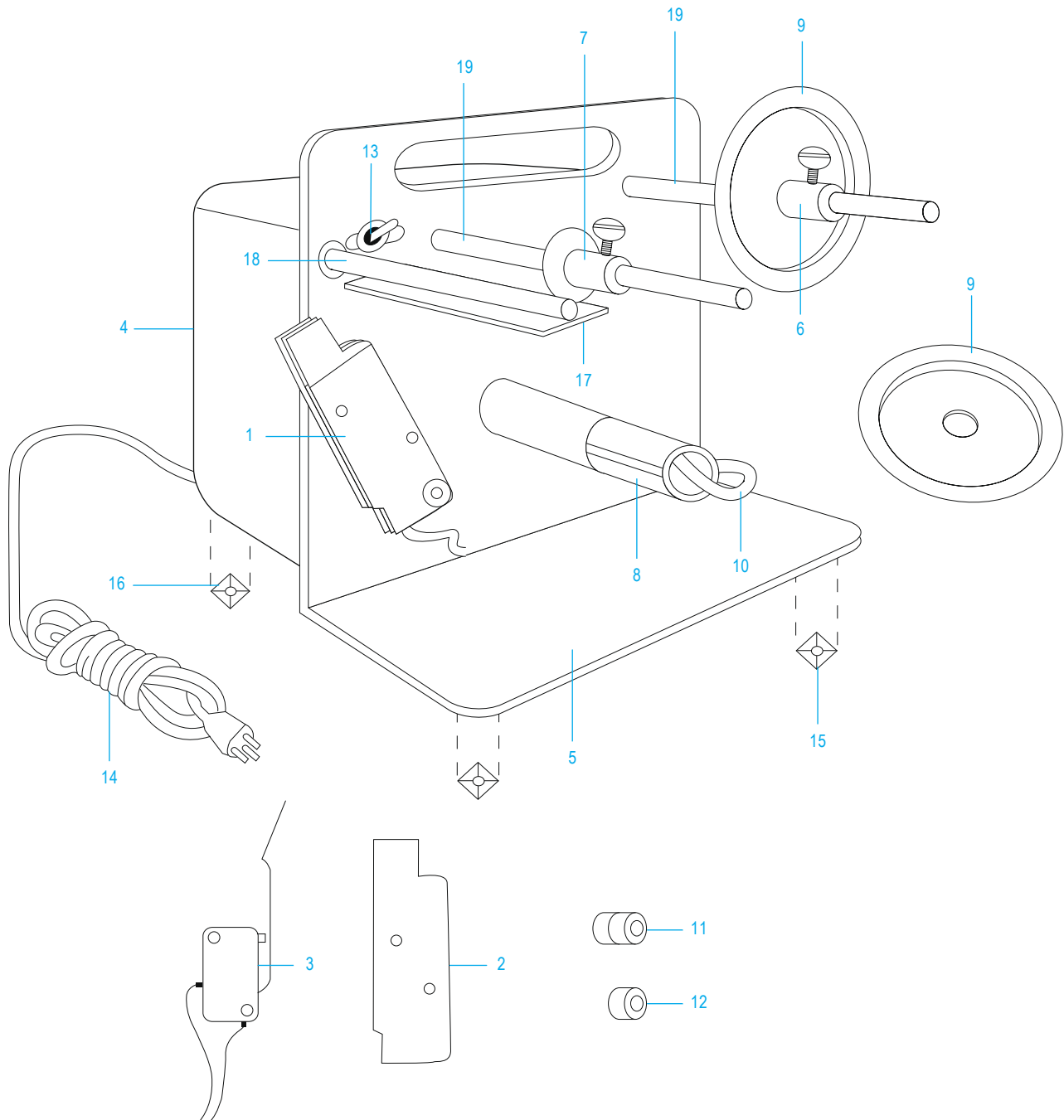
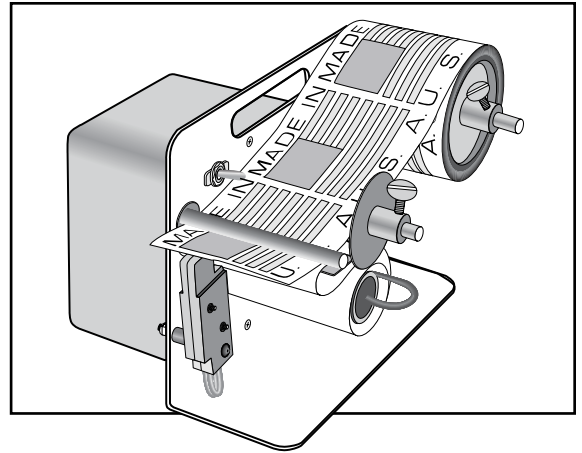

#	DESCRIPTION	QTY.	ULINE PART NO.	MFG. PART NO.
1	Microswitch Housing Assembly	1	H-1276-16105	16105
2	Switch Housing	1	-----	161051
3	Microswitch And Lead Wire	1	H-1276-MICRO	161052
4	Black Motor Housing	1	H-1276-MOTOR	16130
5	Side Frame	1	-----	45160
6	1" Colar For Roll Holder W/ Thumb Screw	1	H-1276-172	45172
7	Side Guide With Thumb Screw	1	H-1276-176	45176
8	Take-Up Spool (For H-1276)	1	H-1276-45200	45200
8	Take-Up Spool (For H-1981)	1	H-1981-60200	U60200
9	Core Insert (Set Of 2)	1	H-1276-201	45201
10	Spring Clip (For H-1276)	1	H-1276-202	45202
10	Spring Clip (For H-1981)	1	H-1981-60203	U60203
11	1/4" Microswitch Spacer	3	H-1276-11	45206
12	1/8" Microswitch Spacer	1	H-1276-12	45205
13	115V Toggle Switch	1	H-1276-13	16121
14	115V Power Cord	1	-----	16125
15	1/4" Rubber Foot	2	-----	45151
16	1/2" Rubber Foot	1	-----	45150
17	Dispensing Table (For H-1276)	1	-----	452501
17	Dispensing Table (For H-1981)	1	-----	U602551
18	4 9/16" Chrome Table Rod (For H-1276)	1	-----	452502
18	6" Chrome Table Rod (For H-1981)	1	-----	U602502
19	5 1/4 Chrome Rod (For H-1276)	2	H-1276-170	45170
19	7" Chrome Rod (For H-1981)	2	-----	U60170
	115V Motor (For H-1276)	1	-----	45120
	115V Motor (For H-1981)	1	-----	U60120
	Foot Pedal	1	H-1276-FOOT	-----
	Large Roll Adapter	1	H-1276-LARGE	45001