

ULINE H-1043 PALLET TRUCK

1-800-295-5510
uline.com

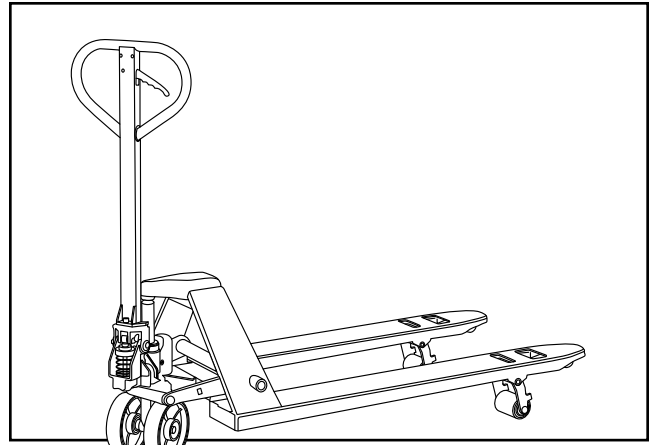

FRAME DIAGRAM

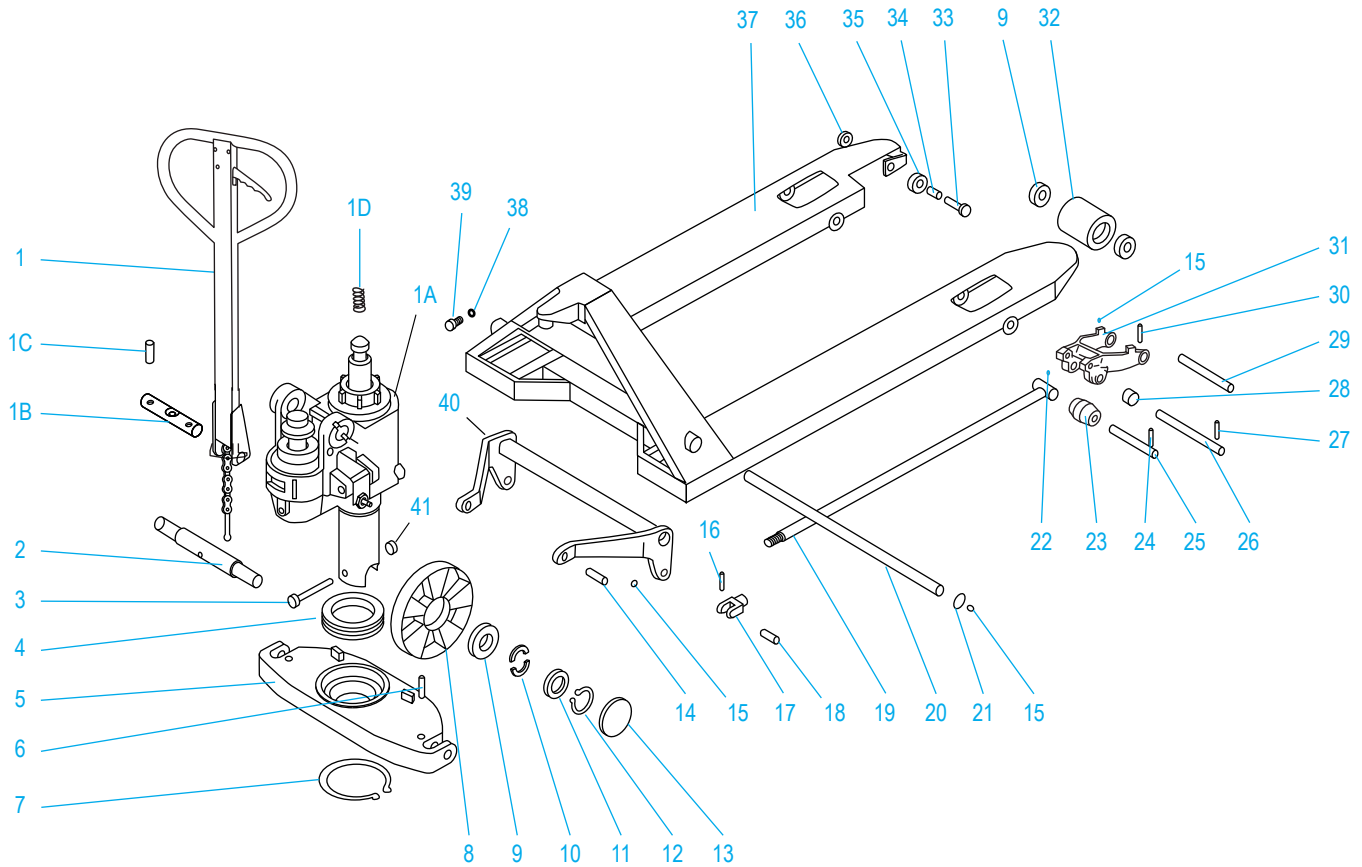

FRAME DIAGRAM PARTS LIST

#	DESCRIPTION	QTY.	ULINE PART NO.	MFG. PART NO.
1	Handle	1	H-1043-SHC	B1
1A	Pump (Standard)	1	H-1043PUMP	-----
1B	Shaft	1	H-1043-B118	B118
1C	Spring Pin	1	H-1043-B117	B117
1D	Big Spring	1	H-1483-B149	B149
2	Big Wheel Shaft	1	H-1366-B2	B2
3	Bolt	1	H-1365-B3	B3
4	Bearing	1	H-1365-B4	B4

FRAME DIAGRAM PARTS LIST CONTINUED

#	DESCRIPTION	QTY.	ULINE PART NO.	MFG. PART NO.
5	Supporting Base	1	H-1043-B5	B5
6	Spring Pin	2	H-1365-B6	B6
7	Retaining Ring For Axle	1	H-1043-B7	B7
8	Big Wheel	2	H-1043-B8	B8
9	Bearing	8	H-1043-B9	B9
10	Half Cirque	4	H-1365-10	B10
11	Bowl Washer	2	H-1366-B11	B11
12	Retaining Ring For Axle	2	H-1366-B12	B12
13	Dust Cover	2	H-1043-B13	B13
14	Pin	2	H-1043-B14	B14
15	Oiler	8	H-1193-B15	B15
16	Spring Pin	2	H-1483-B16	B16
17	Joint	2	H-1483-B17	B17
18	Pin	2	H-1043-B18	B18
19	Straight Tappet	2	H-1483-B19	B19
20	Long Shaft	1	H-1043-B20	B20
21	Retaining Ring For Hole	2	H-1043-B21	B21
22	Oiler	4	H-1043-B22	B22
23	Roll Sheath	2	H-1043-23	B23
24	Spring Pin	2	H-1043-B24	B24
25	Shaft	2	H-1043-25	B25
26	Shaft	2	H-1043-B26	B26
27	Spring Pin	2	H-1043-B27	B27
28	Roll Ring	4	H-1043-B28	B28
29	Shaft	2	H-1483-B29	B29
30	Spring Pin	2	H-1043-B24	B24
31	Frame Of Fork Wheel	2	H-1043-B31	B31
32	Fork Wheel	2	H-1043-B35PU	B35
Kit	Fork Wheel With Bearings (Includes Two Parts #9 and One Part #32)		H-1043-WHKIT	-----
33	Bolt	2	H-1043-B36	B36
34	Sheath	2	H-1043-B37	B37
35	Wheel	2	H-1043-B38	B38
36	Nut	2	H-1043-B39	B39
37	Fork Frame	1	-----	B40
38	Spring Lock Washer	1	H-1043-B41	B41
39	Bolt	1	H-1043-B42	B42
40	Rocker Arm	1	H-1043-B43	B43
41	Nut	1	H-1366-B44	B44

HANDLE DIAGRAM

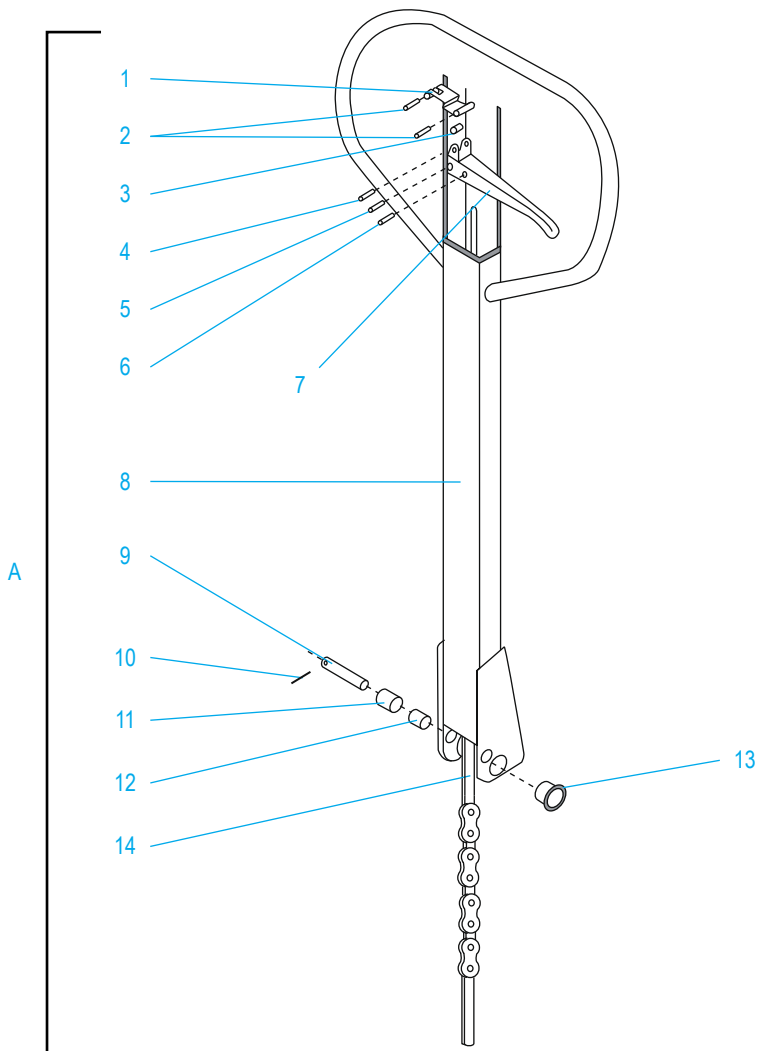

HANDLE DIAGRAM PARTS LIST

#	DESCRIPTION	QTY.	ULINE PART NO.	MFG. PART NO.
A	Handle Assembly	1	H-1043-SHC	B1
1	Blade Spring	1	-----	B101
2	Spring Pin	2	-----	B102
3	Roller	1	-----	B103
4	Spring Pin	1	-----	B104
5	Spring Pin	1	-----	B105
6	Spring Pin	1	-----	B106
7	Handle	1	-----	B107
8	Handle Tube	1	-----	B108
9	Shaft	1	H-1043-109	B109
10	Spring Pin	1	H-1043-B110	B110
11	Pressure Roller	1	-----	B111
12	Bushing	1	-----	B112
13	Bushing	2	-----	B114
14	Pull Pole Assembly	1	H-1043-B113	-----

PUMP DIAGRAM

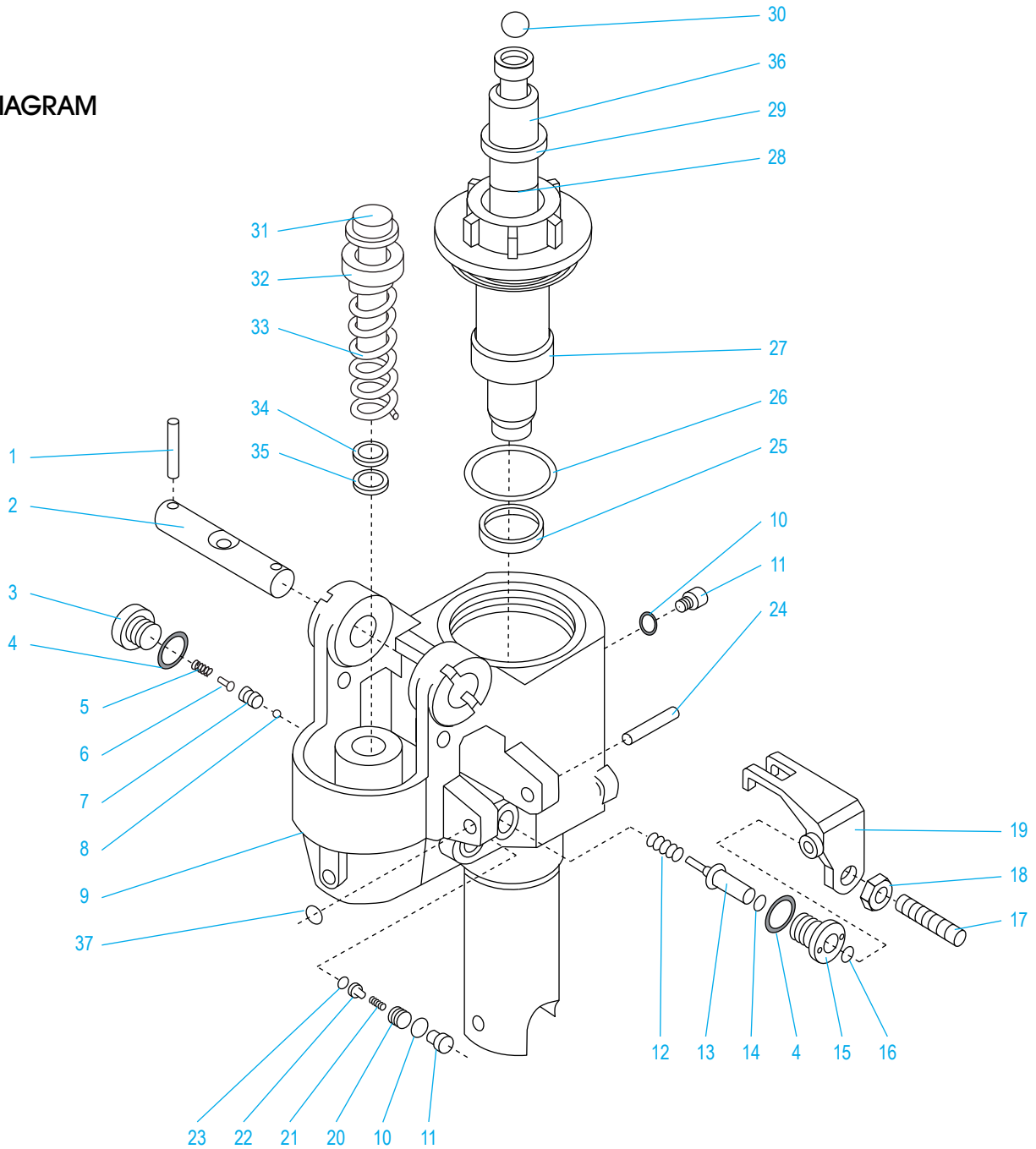

PUMP DIAGRAM PARTS LIST

#	DESCRIPTION	QTY.	ULINE PART NO.	MFG. PART NO.
1	Spring Pin	2	H-1043-B117	B117
2	Shaft	1	H-1043-B118	B118
3	Plug	1	-----	B119
4	Copper Washer	2	H-1043-120	B120

PUMP DIAGRAM PARTS LIST CONTINUED

#	DESCRIPTION	QTY.	ULINE PART NO.	MFG. PART NO.
5	Spring	1	H-1483-B121	B121
6	Spindle Of Damping Valve	1	H-1193-B122	B122
7	Seat Of Damping Valve	1	H-1193-B123	B123
8	Steel Ball	1	-----	B124
9	Base	1	-----	B125
10	Copper Washer	2	-----	B126
11	Bolt	2	-----	B127
12	Spring	1	H-1193-B128	B128
13	Strike Pin	1	H-1193-B129	B129
14	O-Ring	1	H-1193-B130	B130
15	Axle Sleeve	1	-----	B131
16	O-Ring	1	-----	B132
17	Bolt	1	H-1043-B133	B133
18	Nut	1	H-1043-B134	B134
19	Lever	1	H-1043-B135	B135
20	Bolt	1	-----	B136
21	Spring	1	-----	B137
22	Ball Base	1	-----	B138
23	Steel Ball	1	-----	B139
24	Pin	1	H-1043-B140	B140
25	Y-Ring	1	H-1043-B141	B141
26	O-Ring	1	H-1043-B142	B142
27	Cylinder Cap	1	H-1043-B143	B143
28	O-Ring	1	H-1043-B144	B144
29	Dust Ring	1	H-1043-B145	B145
30	Steel Ball	1	H-1043-B146N	B146
31	Bowl Washer	1	-----	B147
32	Washer	1	-----	B148
33	Big Spring	1	H-1483-B149	B149
34	Dust Ring	1	-----	B150
35	Y-Ring	1	-----	B151
36	Piston Rod	1	H-1043-B152	B152
37	Retaining Ring For Axle	1	-----	B153