

INSTRUCTIONS FOR THREADING METAL BUCKLES

- 1** Insert end of strapping up through center of the buckle and around open leg to form a loop. Pull top tight around leg.

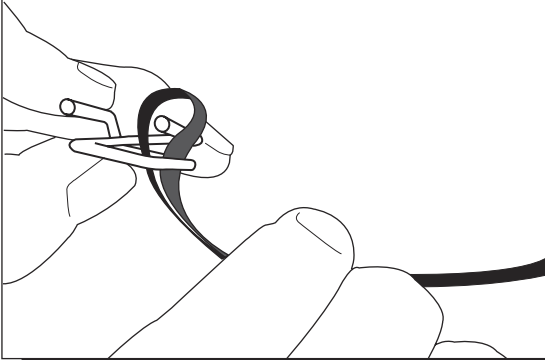

- 2** Wrap strapping around package. Loop strapping around remaining open leg of buckle. Pull loop tight around leg.

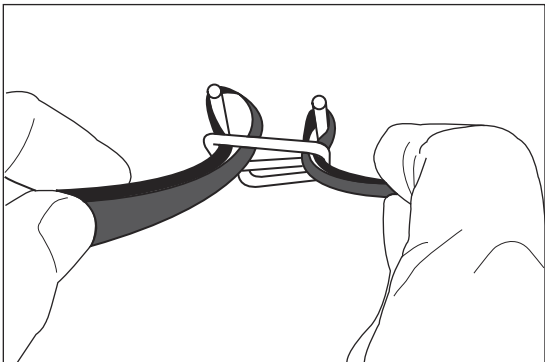
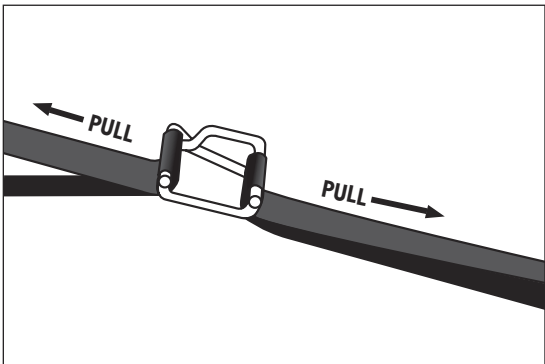

- 3** Pull both top ends of strapping in the opposite direction to manually tighten.