

ULINE

FOOT OPERATED
IMPULSE SEALER
OPERATING INSTRUCTIONS

MODEL: H-86
H-87
H-89

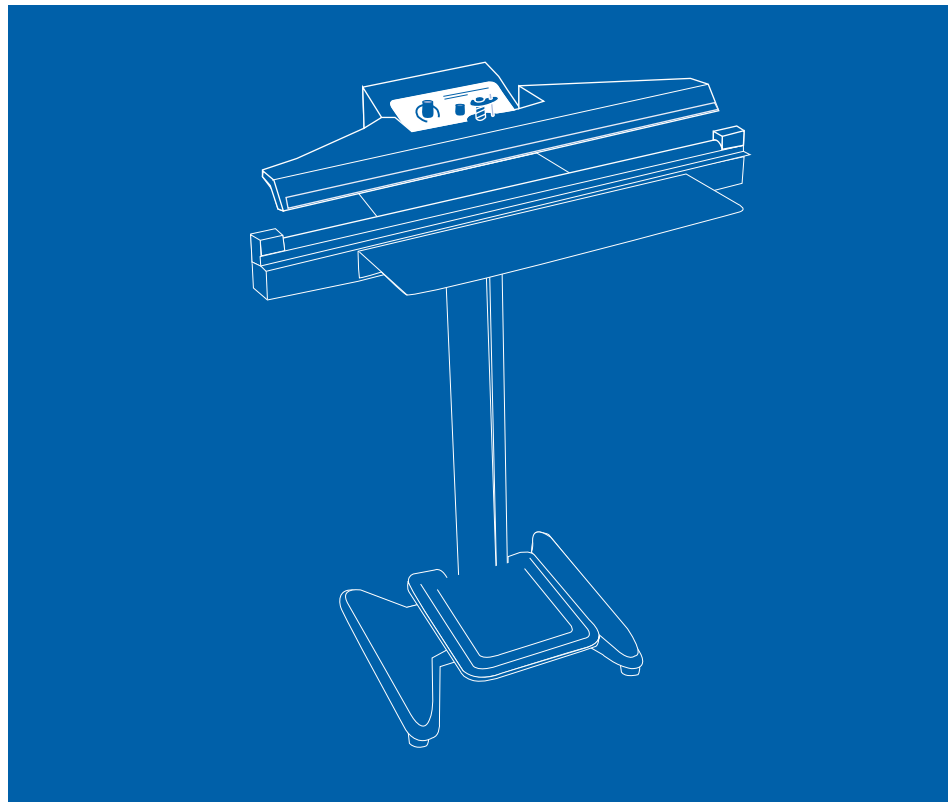

1 PARTS IDENTIFICATION

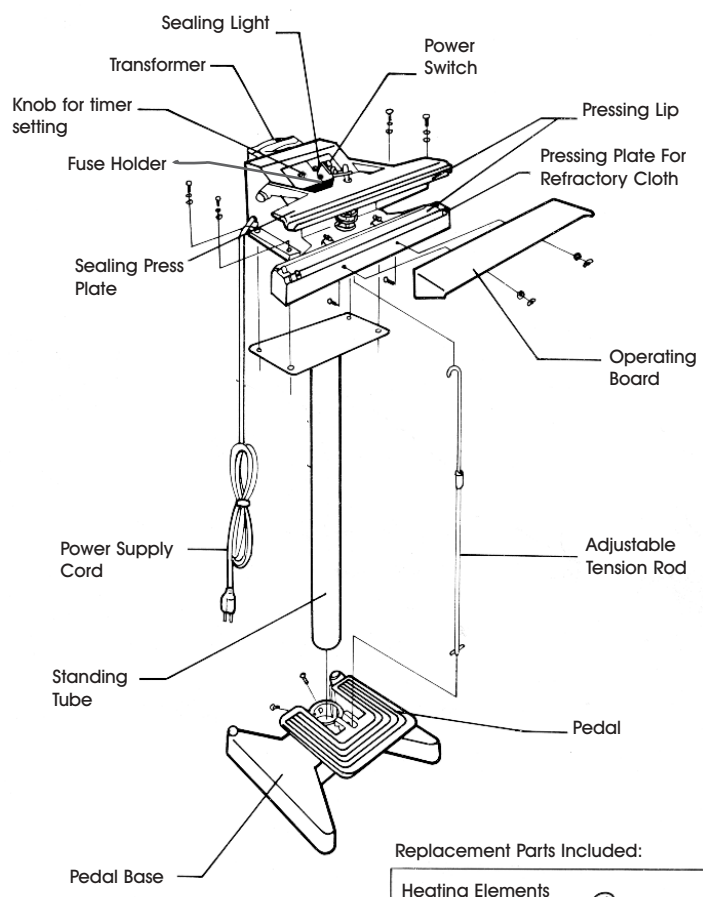

Replacement Parts Included:

Heating Elements	2PCS
Heating Element Fuse	

2

ASSEMBLING INSTRUCTIONS

1. Insert standing tube into pedal base and connect with short screw.

2. With four long screws connect body to stand

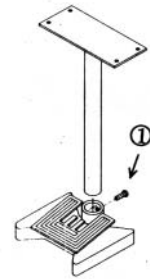
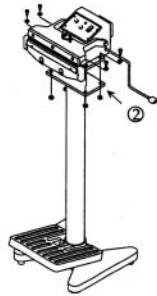

3. Attach tension rod to puller (located under base) and then attach to foot pedal.

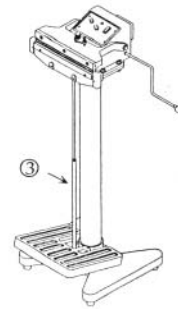

4. Connect working plate fixed bracket to body.

5. Fit operating board over bracket.

Note: When attaching working plate bracket leave enough space between sealer body and top of screws so that operating board can be attached easily.

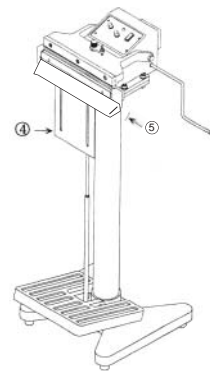

3

OPERATING INSTRUCTIONS

1. Plug in unit.
2. Set power switch to "on".
3. Adjust the timer to the minimum setting necessary for thickness of the poly bag.
4. The sealing time is automatically controlled by the timer—press the foot pedal to begin sealing.
5. When the light turns off, sealing is completed. Wait 1-2 seconds to allow the seal to cool, then release the foot pedal.
6. You can leave the unit plugged in and turned on between seals. No power is used other than during the actual sealing.

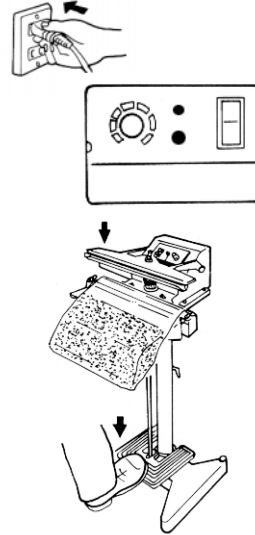

4

SPECIFICATIONS

MODEL	H-87	H-89	H-86
Impulse Power	400 W	600 W	800 W
Seal Width	2 mm	2 mm	2 mm
Max. Seal Length	12"/300mm	18"/450mm	24"/600mm
Max. Seal Thickness	16 Mil	16 Mil	16 Mil
Heat Time	.2~1.7 sec.	.2~1.7 sec.	.2~1.7 sec.
Weight	23 kg	28 kg	34 kg
Dimensions	38 x 35 x 90 CM	54 x 38 x 90 CM	68 x 40 x 90 CM

5

REPLACEMENT PARTS

MODEL	H-87	H-89	H-86
Repair Kit	H-173	H-174	H-204

To replace Teflon roll:

1. Turn off power and unplug unit.
2. Remove pressing plate.
3. Loosen teflon clips.
4. Pull out a new section of the teflon tape, cut off unused portion, then replace pressing plate and tape.
5. Adjust teflon screw to tighten teflon roll.
6. Tighten teflon clips.

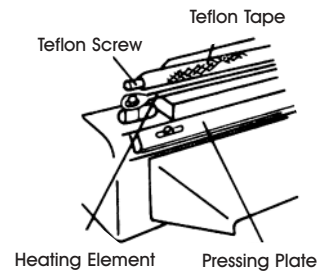

To replace heating element:

1. Turn off power and unplug unit.
2. Release teflon clips.
3. Remove each screw that holds the heating element.
4. Remove old heating element and replace with new one.
5. Reattach and tighten the teflon tape (see previous instructions).

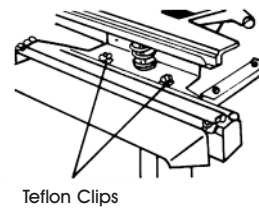

6

CONNECTION DIAGRAM

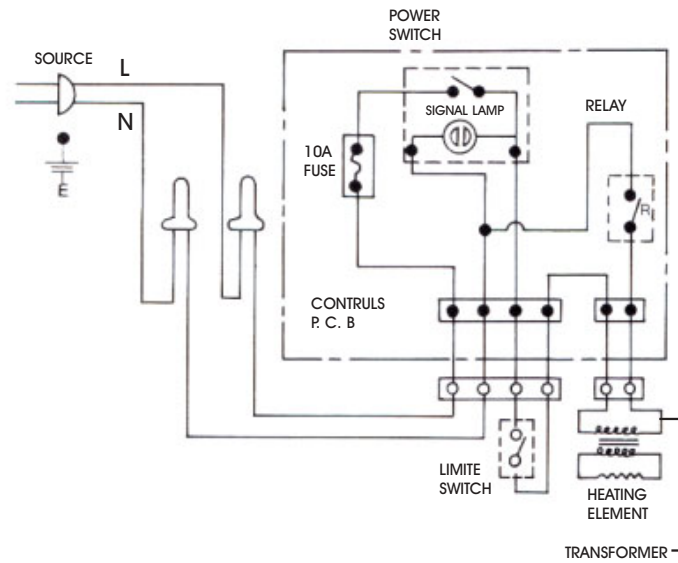

7

ADDITIONAL INFORMATION

- Always keep the sealing platform clean. Remove any residue (typically overheated plastic) from the teflon barrier tape.
- Clean the sealing platform with a dry cloth.
Do not use water or solvents.
- A short circuit will occur if the bottom teflon tape strip wears out. Each time you replace the heating element or the top teflon, check the bottom teflon for wear or damage.
- Only use ULINE replacement parts.
- A worn rubber pressure pad (under the handle) will influence the quality of the seal. The rubber pad should be periodically checked for uneven wear.