

**SIDE LOADER
TAPE DISPENSER****REFERENCE****OPERATION**

1. Place dispenser on flat surface. Push tape roll fully onto dispenser. Be sure tape unwinds with sticky side down. (See Figure 1)
2. Unroll 5-6 inches of tape (sticky side down) and thread between roller and metal loading gate. (See Figure 2)
3. Pull tape over roller allowing tape to unroll freely. (See Figure 3) To adjust tension, see Figure 4.
4. Start desired depth on the side of the box. (See Figure 5, A)
5. Roll dispenser along the carton seam. Tape should be applied evenly and smoothly with pressure being applied by the roller. (See Figure 5, B)
6. Continue down the opposite end to desired length. Tilt dispenser forward, allowing the blade to cut the tape and the wipe down blade to seal down the end of the tape. (See Figure 5, C)

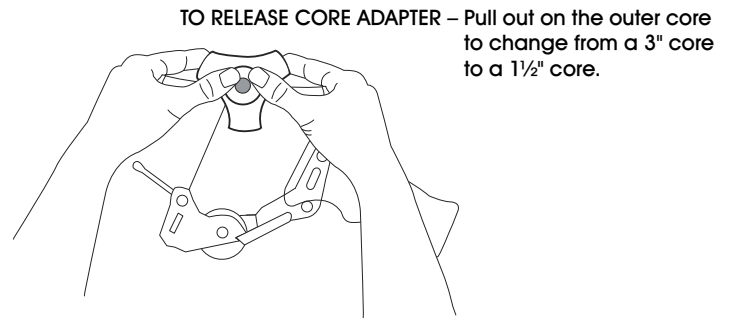
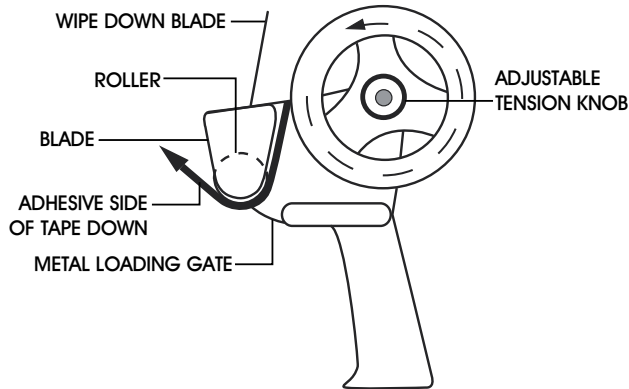