

**ULINE H-669**  
**BETTER PACK**  
**MANUAL TAPE**  
**DISPENSER 333 PLUS**

1-800-295-5510  
uline.com

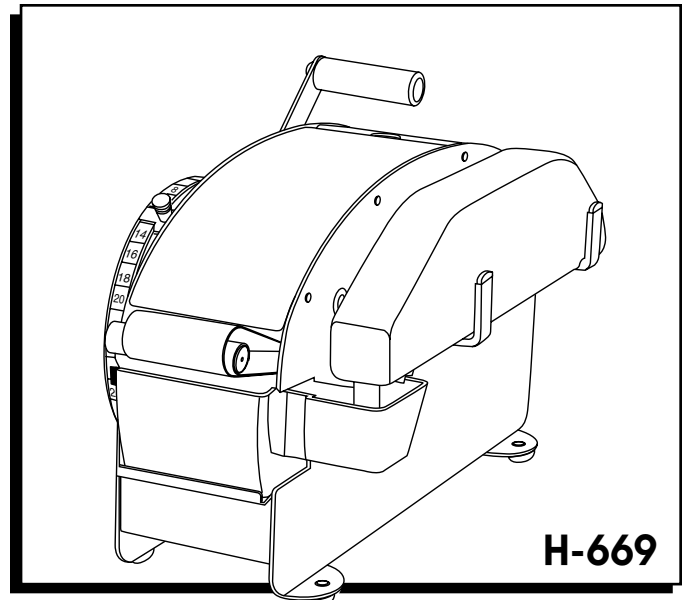

## INSTRUCTIONS

1. Remove old pressure plate assembly by driving the pivot out from the right side of the machine. Be careful not to lose the brass shear support rollers mounted on pin to be driven out.
2. Replace old pressure plate with new top heater assembly on the pin that held the old assembly. Be sure that brass rollers are on the pin, one on each side of the top heater assembly. Use new retaining ring provided to hold pin in place.
3. Pull the heater cord toward the back and under the bottle bracket and between the side frame and water bottle.
4. Place cord clamp on heater cord and, using screw and nut provided, fasten to existing hole just to the rear of the bottle bracket.
5. Be sure there is enough loop in the cord near the heater so that the heater assembly can pivot up and down freely.

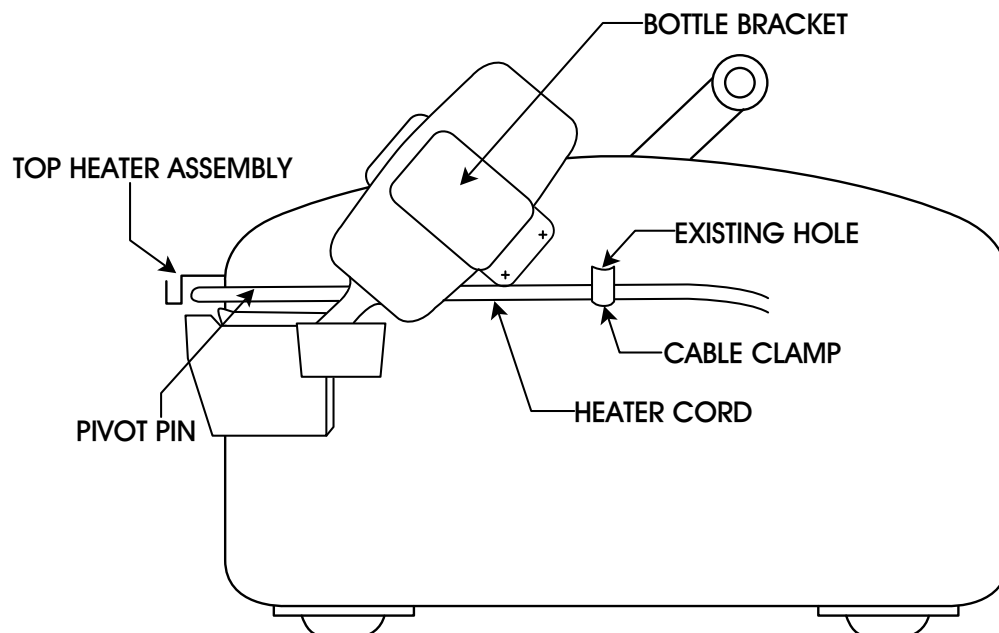

**ULINE** CHICAGO • ATLANTA • DALLAS • LOS ANGELES • MINNEAPOLIS • NYC/PHILA

1-800-295-5510

uline.com

0109 IH-669