

# ULINE H-2086 3-IN-1 HAND TRUCK

1-800-295-5510  
uline.com

## TOOLS NEEDED

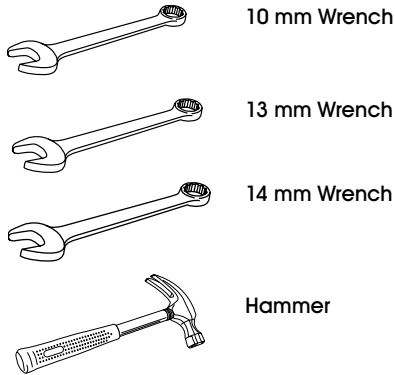

**STOP** WARNING! Do not use power tools.

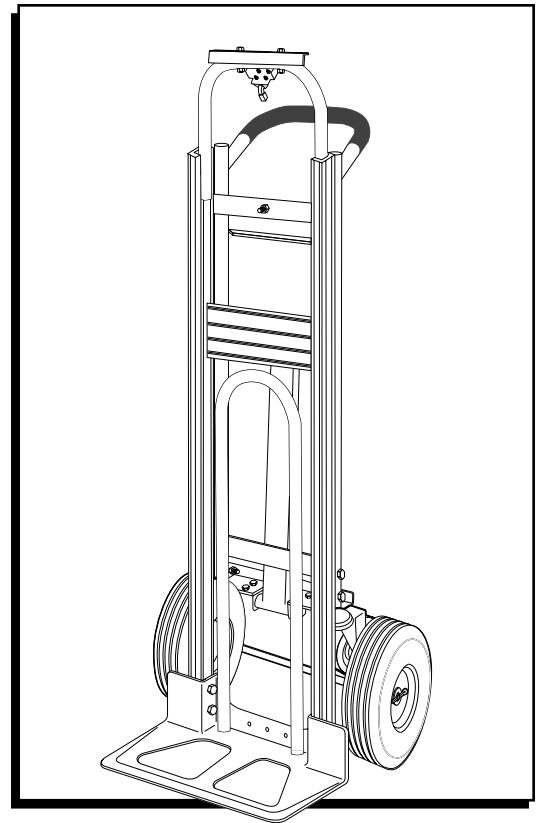

## ASSEMBLY INSTRUCTIONS

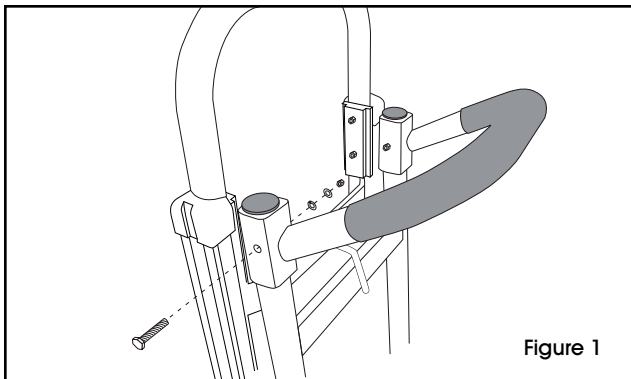

### ATTACH HANDLE

1. Slide handle onto the top rails of frame. Align holes in handle and frame. Insert (2) bolts through handle and frame. Secure with lock nuts. (See Figure 1)

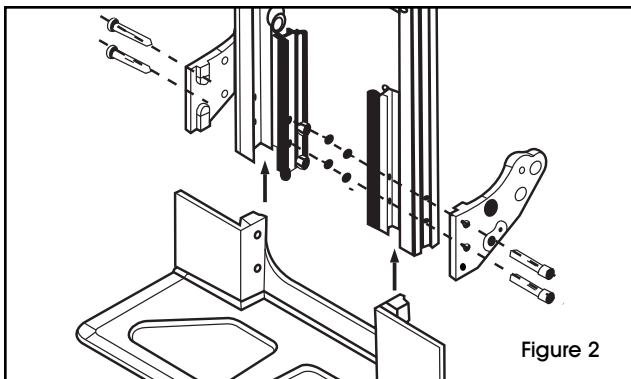

### ATTACH NOSE PLATE, EXTENDED NOSE PLATE, AND AXLE SUPPORTS

1. Position inside reinforcements against bottom of frame rail. Slide nose plate into channel on inside reinforcements. Keep bolt holes aligned. (See Figure 2)
2. Align axle supports with outside rail of frame. Make sure supports are positioned as shown. (See Figure 2)

 **NOTE:** Align top two holes on axle support.

3. Thread (4) long bolts through the axle supports, frame, inside reinforcements and nose plate.

## ASSEMBLY INSTRUCTIONS (CONTINUED)

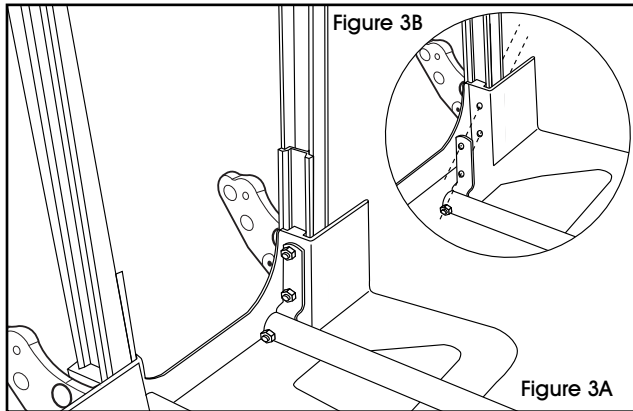

4. Attach extended nose plate through bolt holes. (See Figure 3A)

 **NOTE:** The bolt holes on bracket are **NOT** centered. Make sure the bolt holes are closest to the back of truck before tightening. (See Figure 3B)

5. Secure with lock nuts.

### ATTACH AXLE AND WHEELS

1. Insert axle through hole in axle supports. Align holes in axle with grooves on back of the axle supports. Use a hammer to tap in the round pins. (See Figure 4)
2. Slide a washer onto each end of the axle. Slide wheels onto each end of the axle. Slide another washer on each end, then secure each wheel with a cotter pin (See Figure 5). Wheels should spin freely.

