

FROMM

OPERATION MANUAL / SPARE PARTS LIST

BATTERY - POWERED PLASTIC STRAPPING TOOL MODEL P325

43.0721.01

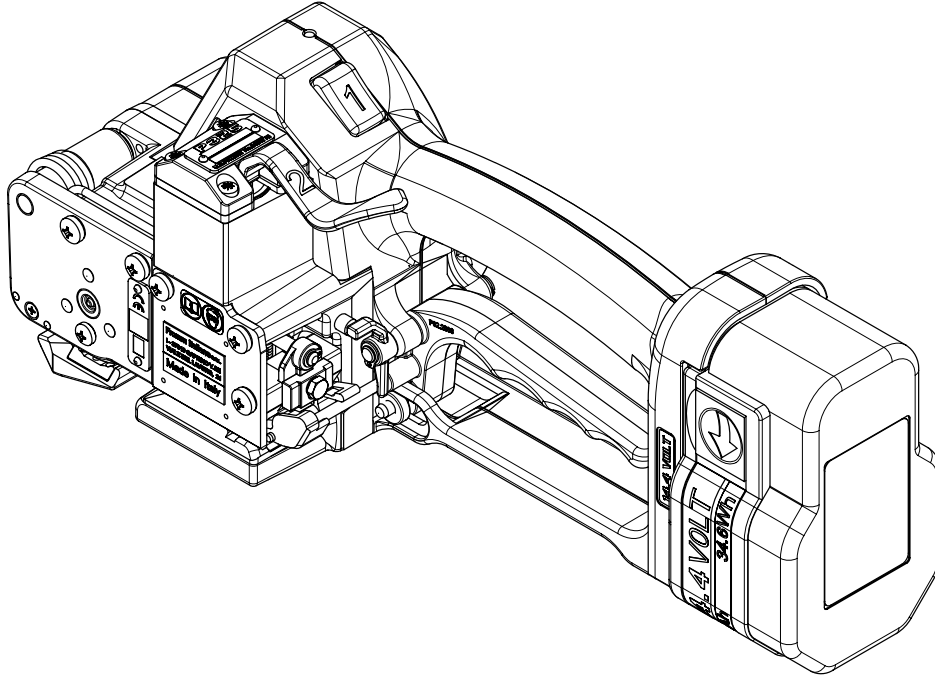

CE Declaration of conformity

We declare that the machine P325
is in conformity with the following standard or
standardised documents:

98/37/EEC

FROMM Holding AG
Hinterbergstrasse 26
CH - 6330 Cham
16.02.2006

R.Fromm
Director



	INDEX	PAGE
1	GENERAL SAFETY RULES	3
2	SAFETY RULES FOR STRAPPING TOOLS	5
3	TECHNICAL DATA	6
4	ACCESSORIES	7
4.1	Battery	7
4.2	Battery - chargers	7
4.3	Wearing plate	8
4.4	Suspension	8
4.5	Turning button kit.	9
5	OPERATING ELEMENTS	10
6	OPERATION	10
6.1	Installation	10
6.2	Adjustments	11
6.3	Feeding the strap around the package	12
6.4	Inserting the strap	12
6.5	Tensioning the strap	12
6.6	Sealing of the joint	13
6.7	Removing the tool	13
6.8	Seal - Control.	13
7	CHART OF TYPES	14
8	ELECTRIC SCHEMATIC	14
9	EXCHANGE OF WEARING PARTS	15
9.1	Exchange of tensioning wheel and grippers	15
9.2	Exchange of cutter, welding stop gripper and welding gripper	16
9.3	Adjustment of the coupler	17
10	SERVICE	17
11	CLEANING	17
12	WARRANTY CONDITIONS AND LIABILITY	18
13	APPROPRIATE USE	18
14	SPARE PARTS LIST 43.0721.01	23

1 GENERAL SAFETY RULES

WARNING! Read all instructions. Failure to follow all instructions listed below may result in electric shock, fire and/ or serious injury. The term "power tool" in all of the warnings listed below refers to your mains operated (corded) power tool or battery operated (cordless) power tool.

SAVE THESE INSTRUCTIONS.

1.1 Work area

- a) **Keep work area clean and well lit.** Cluttered and dark areas invite accidents.
- b) **Do not operate power tools in explosive atmospheres, such as in the presence of flammable liquids, gases or dust.** Power tools create sparks which may ignite the dust or fumes.
- c) **Keep children and bystanders away while operating a power tool.** Distractions can cause you to lose control.

1.2 Electrical safety

- a) **Power tool plugs must match the outlet. Never modify the plug in any way. Do not use any adapter plugs with earthed (grounded) power tools.** Unmodified plugs and matching outlets will reduce the risk of electric shock.
- b) **Avoid body contact with earthed or grounded surfaces such as pipes, radiators, ranges and refrigerators.** There is an increased risk of electric shock if your body is earthed or grounded.
- c) **Do not expose power tools to rain or wet conditions.** Water entering a power tool will increase the risk of electric shock.
- d) **Do not abuse the cord. Never use the cord for carrying, pulling or unplugging the power tool. Keep cord away from heat, oil, sharp edges or moving parts.** Damaged or entangled cords increase the risk of electric shock.
- e) **When operating a power tool outdoors, use an extension cord suitable for outdoor use.** Use of a cord suitable for outdoor use reduces the risk of electric shock.

1.3 Personal safety

- a) **Stay alert, watch what you are doing and use common sense when operating a power tool. Do not use a power tool while you are tired or under the influence of drugs, alcohol or medication.** A moment of inattention while operating power tools may result in serious personal injury.
- b) **Use safety equipment. Always wear eye protection.** Safety equipment such as dust mask, non-skid safety shoes, hard hat, or hearing protection used for appropriate conditions will reduce personal injuries.
- c) **Avoid accidental starting. Ensure the switch is in the off position before plugging in.** Carrying power tools with your finger on the switch or plugging in power tools that have the switch on invites accidents.
- d) **Remove any adjusting key or wrench before turning the power tool on.** A wrench or a key left attached to a rotating part of the power tool may result in personal injury.
- e) **Do not overreach. Keep proper footing and balance at all times.** This enables better control of the power tool in unexpected situations.
- f) **Dress properly. Do not wear loose clothing or jewellery. Keep your hair, clothing and gloves away from moving parts.** Loose clothes, jewellery or long hair can be caught in moving parts.
- g) **If devices are provided for the connection of dust extraction and collection facilities, ensure these are connected and properly used.** Use of these devices can reduce dust related hazards.

1.4 Power tool use and care

- a) **Do not force the power tool. Use the correct power tool for your application.** The correct power tool will do the job better and safer at the rate for which it was designed.
- b) **Do not use the power tool if the switch does not turn it on and off.** Any power tool that cannot be controlled with the switch is dangerous and must be repaired.
- c) **Disconnect the plug from the power source before making any adjustments, changing accessories, or storing power tools.** Such preventive safety measures reduce the risk of starting the power tool accidentally.
- d) **Store idle power tools out of the reach of children and do not allow persons unfamiliar with the power tool or these instructions to operate the power tool.** Power tools are dangerous in the hands of untrained users.
- e) **Maintain power tools. Check for misalignment or binding of moving parts, breakage of parts and any other condition that may affect the operation of the power tool. If damaged, have the power tool repaired before use.** Many accidents are caused by poorly maintained power tools.
- f) **Keep cutting tools sharp and clean.** Properly maintained cutting tools with sharp cutting edges are less likely to bind and are easier to control.
- g) **Use the power tool, accessories and tool bits etc., in accordance with these instructions and in the manner intended for the particular type of power tool, taking into account the working conditions and the work to be performed.** Use of the power tool for operations different from those intended could result in a hazardous situation.

1.5 Battery tool use and care

- a) **Ensure the switch is in the off position before inserting the battery pack.** Inserting the battery pack into power tools that have the switch on invites accidents.
- b) **Recharge only with the charger specified by the manufacturer.** A charger that is suitable for one type of battery pack may create a risk of fire when used with another battery pack.
- c) **Use power tools only with specifically designated battery packs.** Use of any other battery packs may create a risk of injury and fire.
- d) **When the battery pack is not in use, keep it away from other metal objects like paper clips, coins, keys, nails, screws, or other small metal objects that can make a connection from one terminal to another.** Shorting the battery terminals together may cause burns or a fire.
- e) **Under abusive conditions, liquid may be ejected from the battery; avoid contact. If contact accidentally occurs, flush with water. If liquid contacts eyes, additionally seek medical help.** Liquid ejected from the battery may cause irritation or burns.

1.6 Service

- a) **Have your power tool repaired only by qualified personnel using original spare parts.** This will ensure that the safety of the power tool is maintained.

2 SAFETY RULES FOR STRAPPING TOOLS

2.1 Joints

You are fully responsible to review the joints made by your tool. Become familiar with the seal control and seal adjustment described in this operation manual.

Misformed joints may not secure the load and could cause serious injury. Never handle or ship any load with improperly formed joints.

2.2 Dispensing strap

Only dispense strap from a dispenser specifically designed for strap. Tuck strap end back into dispenser when not in use.

2.3 Strap warnings

Never use strap as a means of pulling or lifting loads. Failure to follow these warnings can result in severe personal injury.

2.4 Strap breakage hazard

Improper operation of the tool, excessive tensioning, using strap not recommended for this tool or sharp corners on the load can result in a sudden loss of strap tension or in strap breakage during tensioning, which could result in the following:

- A sudden loss of balance causing you to fall.

- Both tool and strap flying violently towards your face.

Note as follows:

If the load corners are sharp, use edge protectors.

Place the strap correctly around a properly positioned load.

Positioning yourself in-line with the strap, during tensioning and sealing, can result in severe personal injury from flying strap or tool. When tensioning or sealing, position yourself to one side of the strap and keep all bystanders away.

Use the correct strap quality, strap width, strap gauge and strap tensile strength recommended in this manual for your tool. Using strap not recommended for this tool can result in strap breakage during tensioning.

2.5 Cutting tensioned strap

When cutting strapping, use the proper strapping cutter and keep other personnel and yourself at a safe distance from the strap. Always stand to side of the strap, away from the direction the loosened strap end will fly. Use only cutters designed for strap and never hammers, pliers, hacksaws, axes, etc.

2.6 Environment protection

Do not dispose of used batteries in the household refuse, water or by burning them.

FROMM distributors offer an environment friendly battery disposal service.

3 TECHNICAL DATA

Description of the tool

The tool model P325 has been designed to strap packages with plastic strapping. The plastic strapping is fed around the package manually or in combination with a strap feeder. The straps are inserted in the tool, automatically tensioned, sealed by friction welding and separated.

Tool size with battery

Length: 355 mm / 14"

Width: 128 mm / 5"

Height: 128 mm / 5"

Weight: 4.4 kg / 9.7 lbs

Noise information

The A-weighted equivalent continuous sound level at the work place of the machine operator is typical 81 dB (A).

This value was determined according to DIN 45 635 T3 (11.85).

Vibration information

The weighted effective value of the acceleration typically amounts to less than 2,5m/s².

This value was determined according to DIN EN 28 662 T1 (01.93).

Strap material

Strap qualities: PET (Polyester) and PP (Polypropylene) plain or embossed.

Use only plastic straps recommended by your sales shop (name and address on the rear of the operation manual).

Strap dimensions: 16.0 - 19.0 mm x 0.4 - 1.35 mm (see chart of types).

Use only plastic straps with the correct strap dimensions for your tool.

Strap tension

Tensioning force*: Adjustable from 600 - max. 3500 N / 135 - max. 787 lbs.

Tensioning speed*: approx. 100 - 130 mm/s / 3.9 - 5 inch/sec.

Joint strength*: approx. 75% of the tensile strength of the plastic strap.

* The value depends on the strap quality.

Working temperature

The ambient temperature should be between 5° and 45° C (41° and 113°F).

The best performance is achieved between 15° and 20°C (59° and 68°F).

4 ACCESSORIES



Use only parts and accessories mentioned in the operating instruction. Using other parts or accessories can cause injuries to you and other persons.

4.1 Battery

Since the tool can be operated with NiCd or NiMH batteries, the battery is not automatically supplied with the tool. The battery has to be ordered separately under the following item numbers.

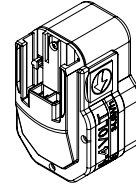

Item-No.	Battery	Voltage	Capacity
N5.4309	NiCd	14,4 VDC	2,4Ah
N5.4316	NiMH	14,4 VDC	3,0Ah

4.2 Battery - chargers

The charge must be ordered separately according to below shown table.

Standard charger

Item-No.	Voltage / frequency	Admitted for country
N5.4414	220 - 240V / 50 - 60Hz	A, B, BG, BIH, BOL, BR, BY, CH, CL, CZ, D, DK, DZ, E, EAS, EST, ET, F, FIN, GE, GR, H, HK, HR, I, IL, IND, IR, IRQ, IS, JOR, KSA, KWT, L, LAR, LT, LV, MA, MC, MK, MOC, N, NL, P, PK, PE, PL, PRC, PY, RA, RCH, RI, RL, RO, ROK, ROU, RP, RUS, S, SK, SLO, SYR, THA, TN, TR, UA, UAE, YU, YV, (Z), (ZA), (ZW)
N5.4416	220 - 240V / 50 - 60Hz	BRN, BRU, CY, EAK, EAT, GB, IRL, M, MAL, OM, SGP, Y
N5.4418	220 - 240V / 50 - 60Hz	AUS, NZ
N5.4420	220V / 60Hz	ROK

Turbo charger

Item-No.	Voltage / frequency	Admitted for country
N5.4422	220 - 240V / 50 - 60Hz	A, B, BG, BIH, BOL, BR, BY, CH, CL, CZ, D, DK, DZ, E, EAS, EST, ET, F, FIN, GE, GR, H, HK, HR, I, IL, IND, IR, IRQ, IS, JOR, KSA, KWT, L, LAR, LT, LV, MA, MC, MK, MOC, N, NL, P, PK, PE, PL, PRC, PY, RA, RCH, RI, RL, RO, ROK, ROU, RP, RUS, S, SK, SLO, SYR, THA, TN, TR, UA, UAE, YU, YV, (Z), (ZA), (ZW)
N5.4424	120V / 60Hz	BR, C, CDN, CO, CR, DOM, EC, GCA, J, JA, KSA, LB, MEX, NIC, PA, Puerto Rico, RC, RP, USA, YV
N5.4426	110V / 50 - 60Hz	GB
N5.4428	220 - 240V / 50 - 60Hz	BRN, BRU, CY, EAK, EAT, GB, IRL, M, MAL, OM, SGP, Y
N5.4430	220 - 240V / 50 - 60Hz	AUS, NZ

Charging times

Item-No.	Battery	Standard charger	Turbo charger
N5.4309	NiCd	approx. 80 min.	approx. 20 min.
N5.4316	NiMH	approx. 85 min.	approx. 25 min.

4.3 Wearing plate

As an option, tool can be equipped with a wearing plate to protect base from excessive wear on abrasive package surfaces (like bricks, concrete blocks etc.). The complete wearing plate can be ordered together with the fastening screws under item number P32.0127.

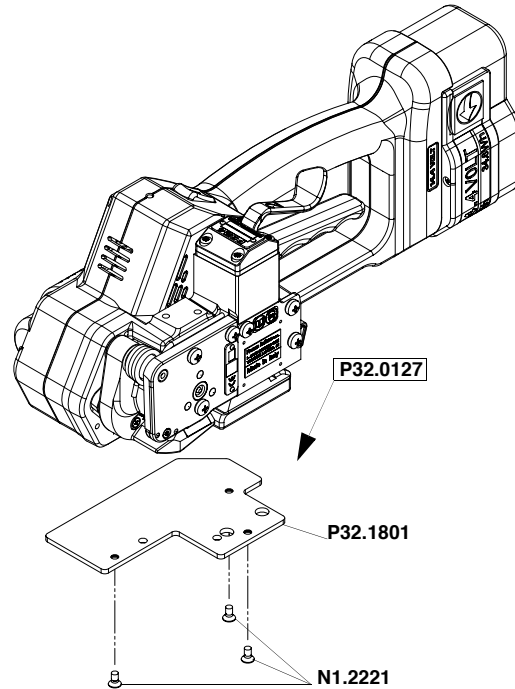

4.4 Suspension

When working stationary the P325 can be suspended at a spring loaded balancer by using a suspension bracket.

For working in normal position a stiff suspension bracket with screws and washers can be ordered under item number P32.0112.

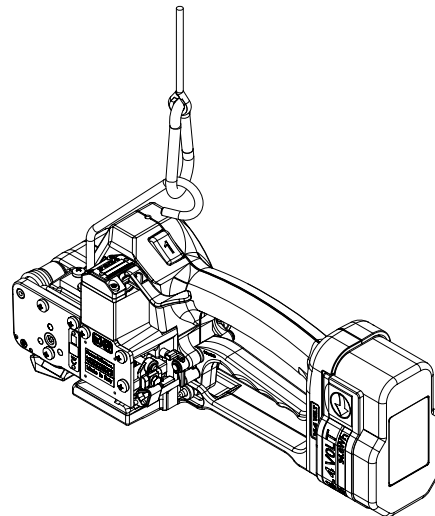
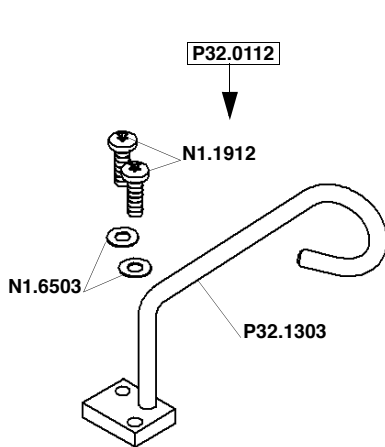

For working in alternating positions a turn able suspension bracket with screws and washers can be ordered under item number P32.0137.

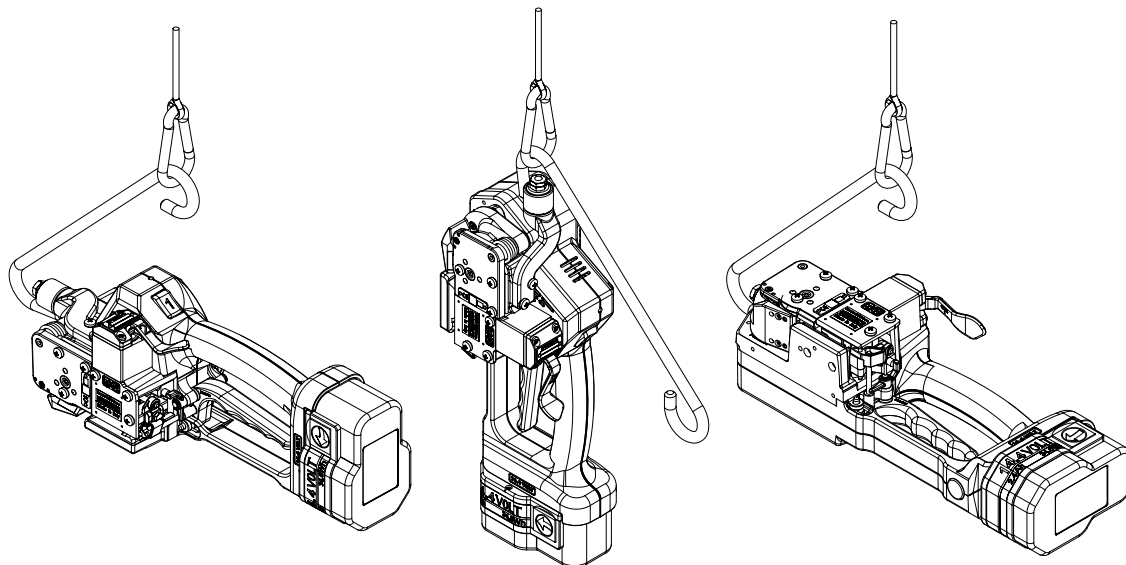
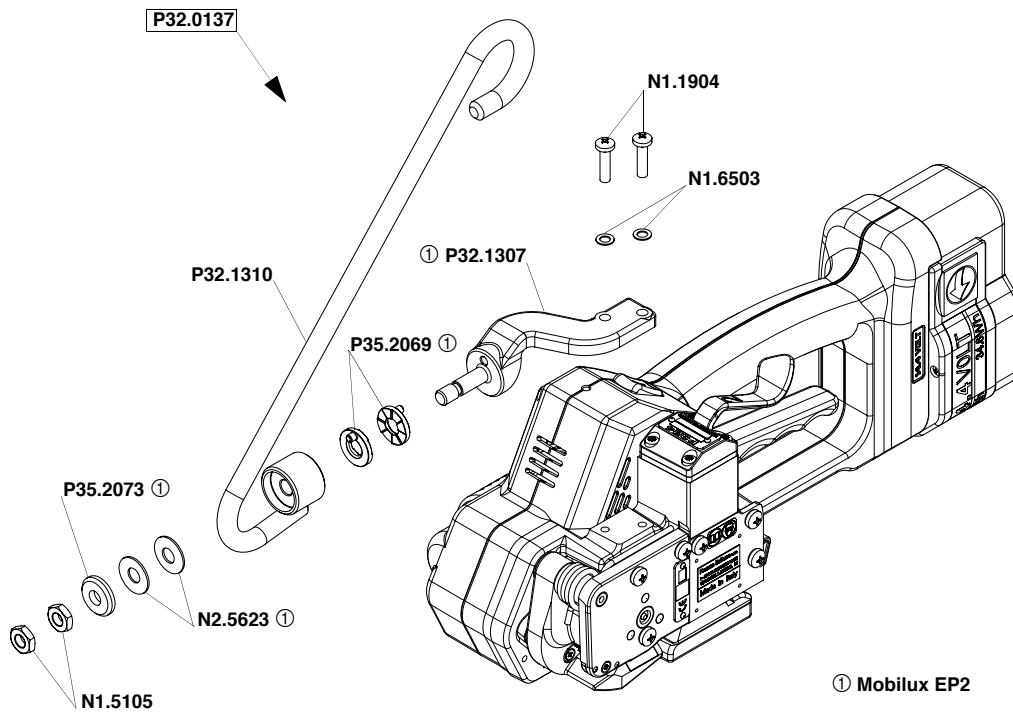

4.5 Turning button kit

For a remaining adjustment of tension force and welding time. After exchanging of the turning buttons the adjustment can only be changed with the allen key (2mm) that comes with the kit. The kit can be ordered under the item number P32.2061.

5 OPERATING ELEMENTS

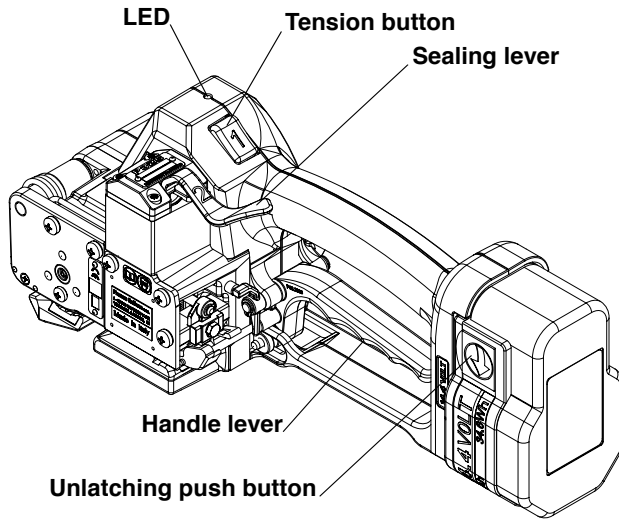

LED - Indication	
Green	During tensioning the LED lights green.
Green	During welding the LED lights green.
Yellow	Cooling time is running, the tool must not be removed from the strap.
Green	Cooling time is finished, the tool can be removed from the strap.
Red	Charge the battery.
Red blinking	The control board is overheated, the tool has to cool down, the switches are locked.

6 OPERATION

6.1 Installation

Do not expose power tools to rain or wet conditions!

For safety reasons the battery is delivered uncharged.

Charge the battery before working. See separate operating instruction of the battery charger.

Never charge a damaged battery. Replace by a new one immediately.

Do not open batteries and store them only in dry and frost-proof rooms.

The maximum ambient temperature is 50°C.

Keep dry at all times.

Inserting the battery

Insert the battery from bottom to top into the tool **both unlatching push buttons latch.**

When inserting the battery the status of the charge is displayed shortly.

Displaying of the status of the battery charge by LED

Green blinking	full
Green yellow blinking	3/4 full
Yellow blinking	1/2 full
Yellow - red blinking	1/4 full
Red blinking	empty

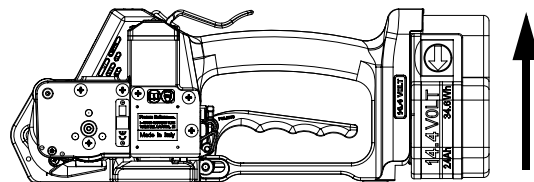

Removing the empty battery

If the red LED starts lighting while a tensioning or welding procedure, the capacity of the battery is exhausted. All electric functions of the tool are blocked.



The seal efficiency is insufficient.
Warning! Straps with insufficient seal strength must be removed from the package!

The battery must be recharged.
 Push the unlatching push buttons at both sides of the battery.
 Push the battery out of the tool in the opposite direction of insertion.
 When removing the battery the LED lights shortly red.

6.2 Adjustments

6.2.1 Preselecting of strap tension and tensioning speed



Do not adjust the tensioning force too high.
If the tensioning force is higher than the tensioning strength of the strap, the strap will tear while the tensioning.

Tensioning force and tensioning speed can be preselected with the upper adjusting knob.
 Turning clockwise increases;
 turning counter clockwise decreases the tensioning force and the tensioning speed resp..
 The tensioning force on the minimum setting is 600 N (135 lbs) and it is increased on the maximum setting to 3500 N (787 lbs).
 The tensioning speed on the minimum setting is 100 mm/s (3.9 inch/sec), it is increased on the middle setting to 130 mm/s (5 inch/sec) and remains on this value till the maximum setting.

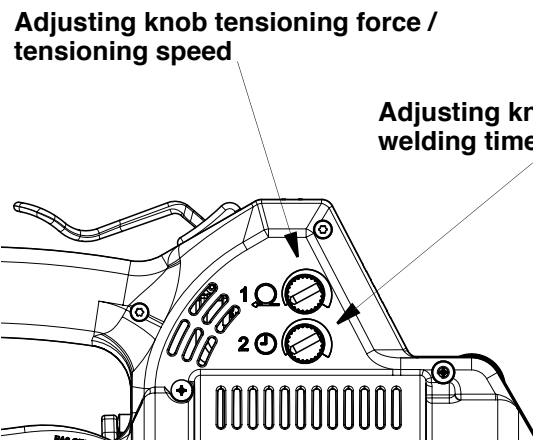

6.2.2 Adjusting the welding time

Depending on the size and quality of the strap, different welding times are required.
 The welding time can be adjusted at the lower adjusting knob.
 Turning clockwise increases,
 turning counter clockwise decreases the welding time.

6.3 Feeding the strap around the package

The strapping is fed around the package as illustrated.

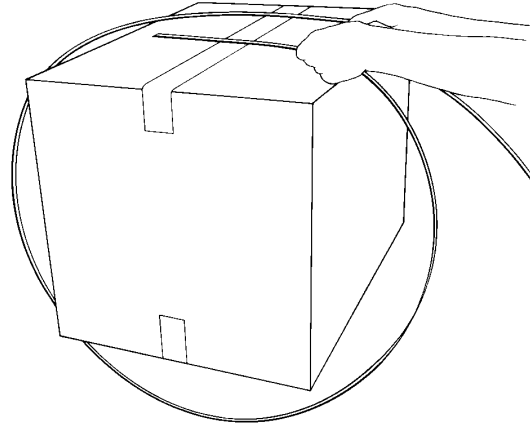

Warning! The plastic strap which will be welded must be free from oil, grease and other dirt. Dirty plastic straps can't be welded correct!

6.4 Inserting the strap

Pull up the handle lever firmly with your right hand.
Insert the two straps well aligned on each other into the strap guide using your left hand.
Release the handle lever.

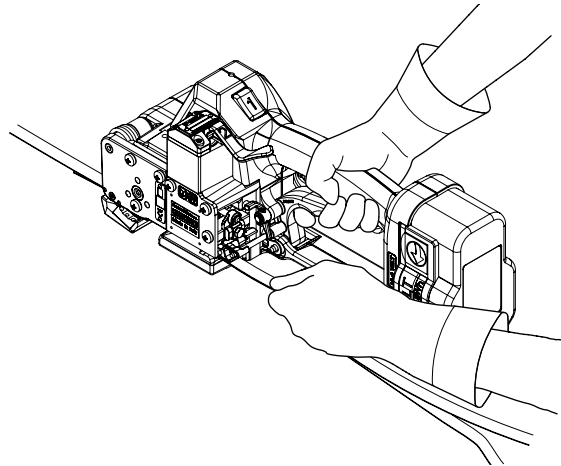

6.5 Tensioning the strap

Press down the tension button and then release it again after the desired strap tension has been reached.

The tensioning operation can be interrupted and restarted at any time.
During tensioning the LED lights green.

**Do not press the tension button after reaching the preselected tensioning.
Danger of strap breakage.**



The tool must carry out a balance movement while tensioning.

Therefore:

- Don't hinder the tools movement in the signed direction.

Disregard:

- The feed wheel slips on the strap without tensioning it.

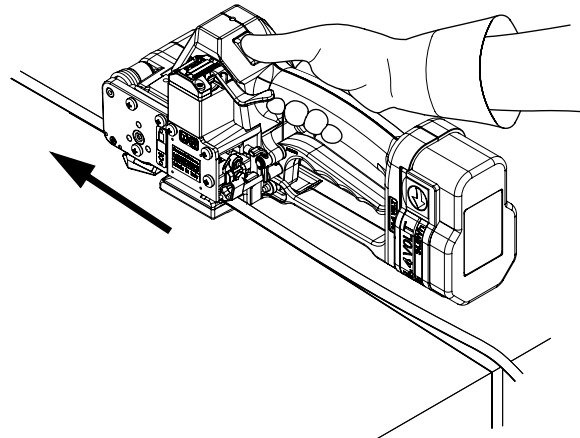

6.6 Sealing of the joint

Press sealing lever down until it locks and let it go immediately.
 The plastic strap is welded and cut off from the rest of the strap.
 During the welding the LED lights green.

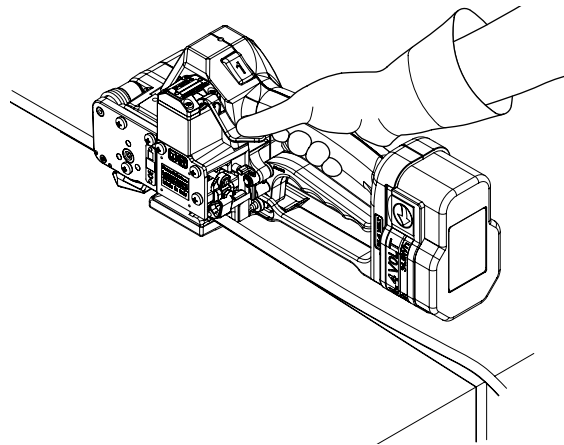

After elapsing of the adjusted welding time (see 6.2.2) the cooling time begins (LED lights yellow).
 During that time the tool must not be removed from the strap.
 If the LED lights green again, the sealing cycle is finished.



The tool must not be removed from the strap as long as the cooling time is not finished. Disregard of this regulation is causing insufficient seal efficiencies, which can cause severe injuries.

6.7 Removing the tool

Pull up the handle lever,
 pull the tool right / backwards and off the strapping.

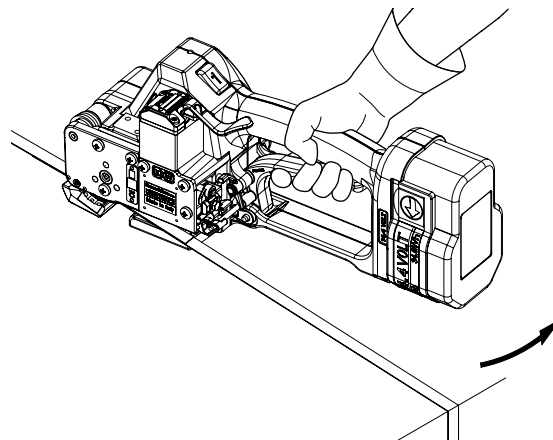

6.8 Seal - Control

A regular control of the seal is necessary. The seal can be examined visually.
 Make a seal, peel it apart and examine it as follows:



Correct seal

The seal must be completely welded over the whole width of the strap on a length of ca. 19 mm. Minor quantities of fused plastic may overflow on sides.



Welding time too short

The plastic strap is not welded over the whole width of the strap. The seal efficiency is insufficient.
 Warning! Straps with insufficient seal strength must be removed from the package! Adjust the welding time (see 6.2.2).



Welding time too long

If the welding time is too long the straps are overheated. The fused plastic overflows on both sides of the straps. The seal efficiency is affected.
 Warning! Straps with insufficient seal strength must be removed from the package! Adjust the welding time (see 6.2.2).

7 CHART OF TYPES

Item No.	Model	Strap width	Strap thickness
43.0721	P325/16/0.65-1.05	16 mm / 5/8"	0.65-1.05 mm / .026 - .041"
43.0722	P325/16/1.06-1.35	16 mm / 5/8"	1.06-1.35 mm / .042 - .053"
43.0731	P325/19/0.40-0.64	19 mm / 3/4"	0.40-0.64 mm / .016 - .025"
43.0732	P325/19/0.65-1.05	19 mm / 3/4"	0.65-1.05 mm / .026 - .041"
43.0733	P325/19/1.06-1.35	19 mm / 3/4"	1.06-1.35 mm / .042 - .053"

8 ELECTRIC SCHEMATIC

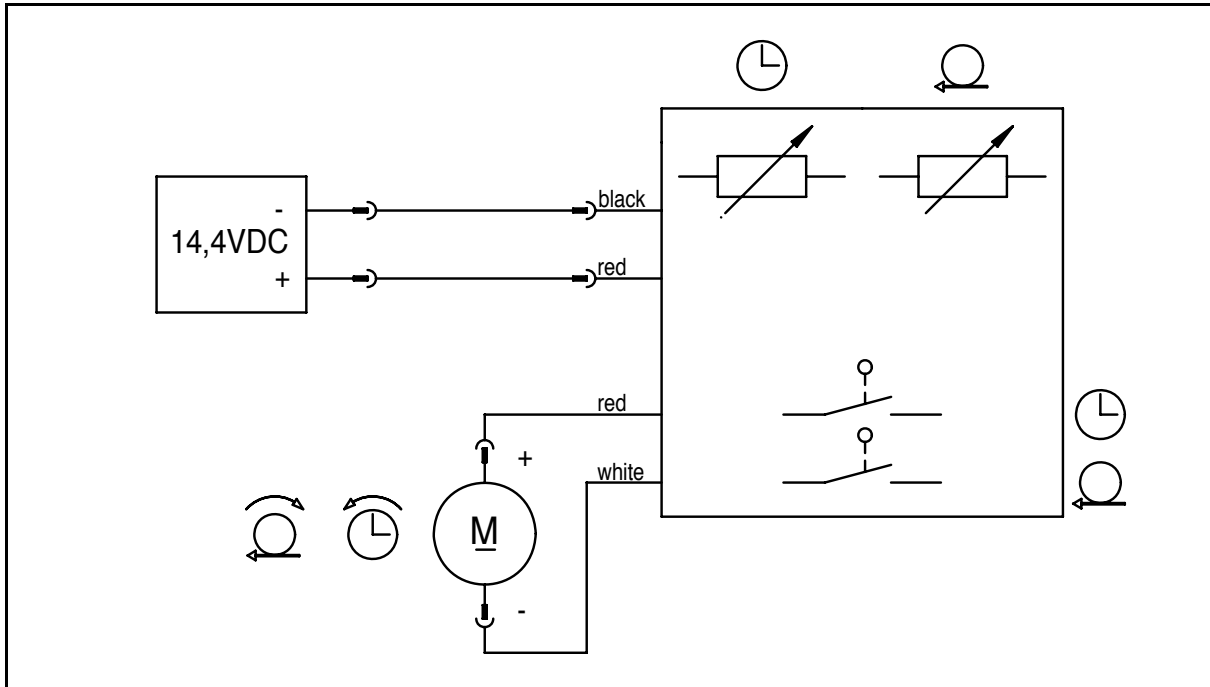

9 EXCHANGE OF WEARING PARTS



Remove always the battery from the tool before starting maintenance works.

9.1 Exchange of tensioning wheel and grippers

Disassembling

- Unscrew end cover P35.3211 and remove it;
- Remove the torsion spring N2.5823;
- Remove the tensioning body;
- Remove the tensioning wheel together with the bearing N3.1172 from the tool;
- Unscrew the holders and remove them from the tensioning body;
- Remove the grippers from the tensioning body.

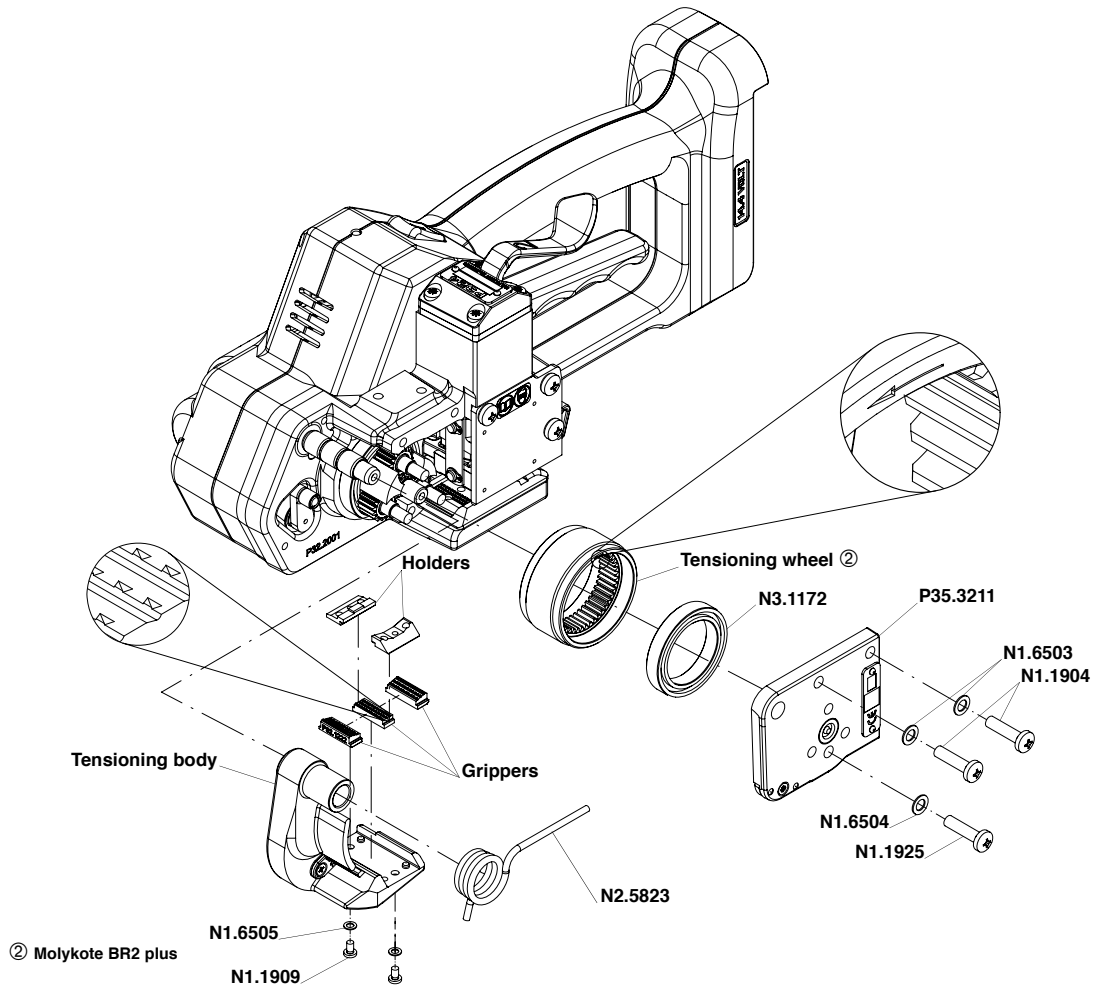

Assembling

Assembling in opposite order. Observe the following:

- Lubricate the internal tothing of the tensioning wheel with Molykote BR 2 plus.
Observe the position of the tensioning wheel. The direction of rotation of the tensioning wheel is marked at the front of the tensioning wheel (see drawing).
Observe the position of the grippers (see drawing).



Assembling

Assembling in opposite order. Observe the following:



Pay attention to the fitting position of the cutter (see drawing).
Safe the screws N1.1305 with Loctite 222.
Observe the position of the tensioning wheel. The direction of rotation of the tensioning wheel is marked at the front of the tensioning wheel (see 9.1).

Lubrication

- Lubricate the rocker and the bolt P32.1028 in the area of the welding jaw with Klüber Isoflex NBU 15.
- Lubricate the balls, ball cage and the running surface of the balls on the welding gripper with Klüber Isoflex Alltime SL2.
- Lubricate the cutter and the driver with Mobilux EP2.
- Lubricate the internal toothing of the tensioning wheel with Molykote BR 2 plus.

9.3 Adjustment of the coupler

The coupler is adjusted in our works.

In case of replacing the seesaw lever, the coupler or the lever body, the coupler has to be readjusted.

Procedure as follows:

The battery is removed from the tool.

The coupler is fitted into the tool.

- Loosen screw N1.1553.
- Displace thrust piece, so that it touches the two seesaw levers without moving them.
- Retighten screw N1.1553.

Control:

The thrust piece must touch the seesaw levers (X1).

Both guide pins must sit on the welding stop gripper (X2).

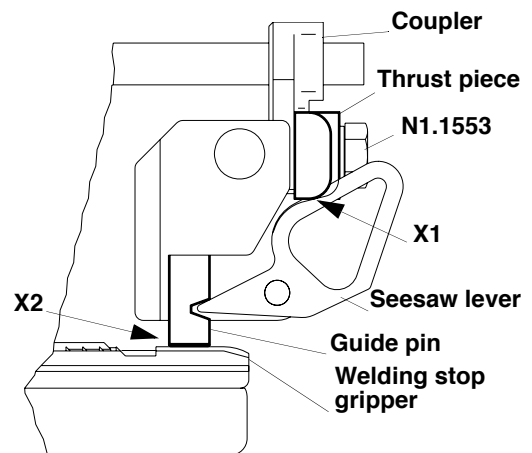

10 SERVICE

Servicing and repair work must only be carried out by authorized service centres.

If the tool breaks down or does no longer operate do not disassemble it. Send it fully assembled to the local service centre (see name and address on the rear page of this manual). Use original packing.

The battery powered plastic strapping tool P325 is a high performance tool. We strongly recommend you to have it serviced by an authorized service shop after 12 months at the latest if used one shift per day. If used two or more shifts per day the tool has to be serviced after a shorter period of time.

11 CLEANING

Clean strap gripping parts from strap abrasion regularly using compressed air (do not use any mechanical tool for cleaning).

When cleaning the surface of the tool do not use water or aggressive solvents!

12 WARRANTY CONDITIONS AND LIABILITY

FROMM Holding AG warrants all its strapping tools and machine heads during a period of 90 days from the date of sale. The warranty includes all deficiencies clearly resulting from poor manufacturing or faulty materials. Damage claims as a result of production shutdowns and claims for damage to persons and to property resulting from warranty deficiencies cannot be asserted by the customer.

The warranty excludes:

- wearing parts,
- deficiencies resulting from improper installing, incorrect handling and maintaining the tool,
- deficiencies resulting from using the tool without or with defective security- and safety devices,
- disregard of directions in the operation manual,
- arbitrary modifications of the tool,
- deficient control of wearing parts,
- deficient repair works of the tool.
- Use of consumable products not recommended by FROMM Holding AG

We reserve the right to modify the product at any time in order to improve its quality.

13 APPROPRIATE USE

The tool model P325 has been designed to strap packages with plastic strapping exclusively.

The warranty / liability excludes:

- non appropriate use of the tool,
- disregard of directions in the operation manual,
- disregard of control- and maintenance instructions.