

# ULINE H-156, H-165 INDUSTRIAL TOP LOADER TAPE DISPENSER

1-800-295-5510  
uline.com

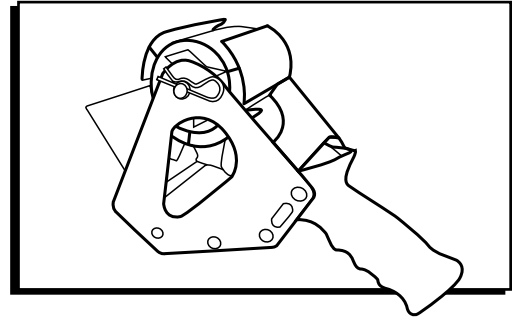

## PARTS

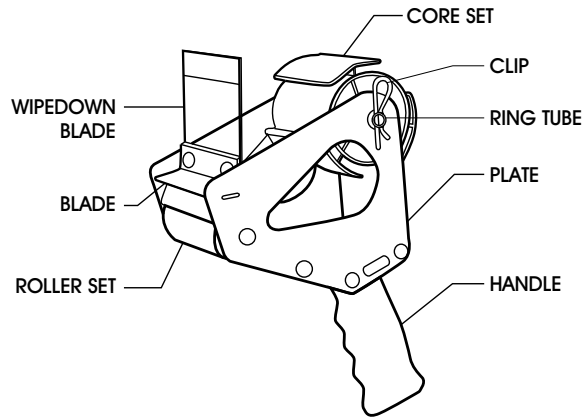

## LOADING INSTRUCTIONS

1. Take the Clip off. (See Figure 1)
2. Pull the Ring Tube out. (See Figure 2)
3. Press the Core Set out from the dispenser. (See Figure 3)
4. Load the tape on the Core Set. Make sure the break disk with springs is upside down to the table. (See Figure 4)
5. Put the core with tape into the dispenser. (See Figure 5)
6. Load the Ring Tube back into the core. (See Figure 6)
7. Lock the Ring Tube with the Clip. (See Figure 7)
8. Thread tape thru the dispenser with the adhesive-side down. (See Figure 8)

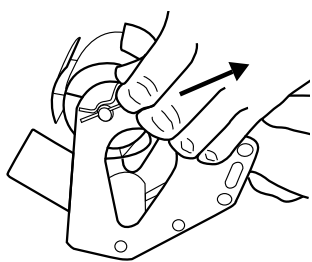

Figure 1

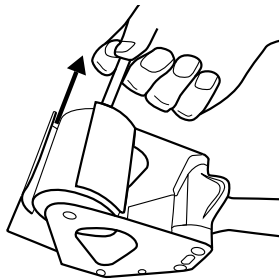

Figure 2

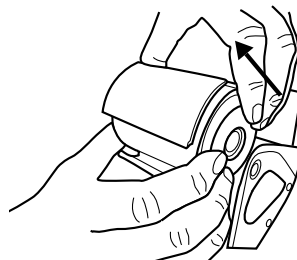

Figure 3

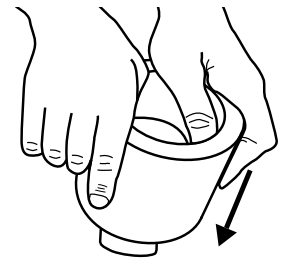

Figure 4

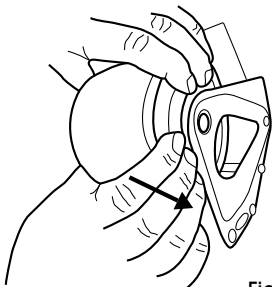

Figure 5

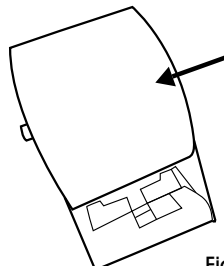

Figure 6

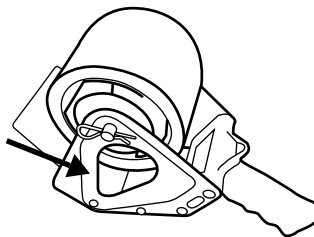

Figure 7

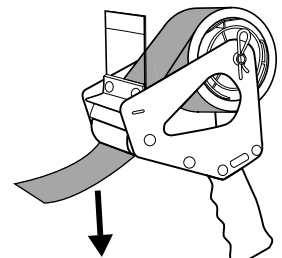

Figure 8